

# **RP07**

## **Service Manual**

**digital**

**RP07 DISK DRIVE  
SERVICE MANUAL**

**ER-ORP07-SV**

October 1980

STATIC KIT

29-11762

# HANDBOOK CHANGE BULLETIN

---

**BOOK:** ER-ORP07-SV DIGITAL  
EQUIPMENT CORPORATION  
RP07 DISK STORAGE DRIVE  
SERVICE MANUAL

**ORIGINAL COVER DATE:** October 1980  
**HC B RELEASE DATE:** April 1983  
**HC B REVISION LEVEL:** F

## DESCRIPTION OF CHANGES:

Vertical bars in the margins of the attached revised pages indicate where maintenance data has been added, deleted, or revised. A new page that contains new or revised data or a page that was completely rewritten will have a vertical bar adjacent to the page number only. A new page containing no new or revised data will only carry the new revision level at the bottom of the page.

## CHAPTERS AFFECTED BY THIS HCB:

Contents, Chapters 1, 2, 4 and 5.

## INSTRUCTIONS:

All revised pages are labeled REV: F.

<u>Chapter</u>	<u>Remove Pages</u>	<u>Insert Pages</u>
Contents	iii thru x	iii thru x
1	1-13 1-14 1-27 1-34 thru 1-36	1-13 1-14 1-27 1-34 thru 1-36
2	2-1 2-6 thru 2-16 2-18 2-20 2-21 2-40 2-54 thru 2-57 2-59 thru 2-61	2-1 2-6 thru 2-16 2-18 2-20 2-21 2-40 2-54 thru 2-57 2-59 thru 2-61
4	4-6 thru 4-8 4-14 4-16 thru 4-18 4-20 4-21 4-23 4-24 4-31 4-42 thru 4-140	4-6 thru 4-8 4-14 4-16 thru 4-18 4-20 4-21 4-23 4-24 4-31 4-42 thru 4-140
5	5-7	5-7

Retain this HCB sheet behind the book's title page.

# MANUAL CONFIGURATION CONTROL INDEX

---

<b>HCBS REV:</b> <b>DATE:</b>	<b>Orig</b> <b>10-80</b>	iii thru ix, 1-1 thru 1-37, 2-1 thru 2-58, 3-1 thru 3-143, 4-1 thru 4-121, 5-1 thru 5-14, A-1 thru A-16.
<b>HCBS REV:</b> <b>DATE:</b>	<b>A</b> <b>4-81</b>	iii thru x, 1-1, 1-23, 2-3, 2-7/2-8, 2-11/2-12, 2-15, 2-16, 2-18 thru 2-65/2-66, 3-5, 3-6, 3-9 thru 3-12, 3-15 thru 3-19, 3-21, 3-22, 3-23, 3-26, 3-38, 3-39, 3-147/3-148, 3-149/3-150, 4-1/4-2, 4-17, 4-22, 4-26, 4-28, 4-32, 4-38, 4-39, 4-45, 4-46, 4-47, 4-48, 4-51 thru 4-126, 5-8 thru 5-15, B-1, B-2, B-3
<b>HCBS REV:</b> <b>DATE:</b>	<b>B</b> <b>7-81</b>	iv, vii, viii, ix, x, 2-32, 2-34 thru 2-40, 2-42 thru 2-66, 4-13, 4-88, 4-89, 4-90, 4-91, 4-94, 4-95, 4-96, 4-97, 4-111, 4-113, 4-118, 4-119, 4-121, 4-123, 4-124, 4-125, 4-126
<b>HCBS REV:</b> <b>DATE:</b>	<b>C</b> <b>10-81</b>	2-16, 1-46, 2-47, 4-45, 4-46, 4-48, B-1, B-2, B-3
<b>HCBS REV:</b> <b>DATE:</b>	<b>D</b> <b>4-82</b>	2-54, 2-55, 2-57, 2-58, 2-59, 2-61, 2-63 thru 2-66, 3-9, 3-10, 4-20, 4-21, 4-41 thru 4-51, 4-68, 4-70, 4-73
<b>HCBS REV:</b> <b>DATE:</b>	<b>E</b> <b>7-82</b>	iv thru x, 1-13, 1-25, 2-7/2-8, 2-11/2-12, 2-15 thru 2-17, 2-21, 2-27 thru 2-68, 3-2, 4-6, 4-7/4-8, 4-12, 4-14, 4-18, 4-19, 4-29, 4-32, 4-41 thru 4-129, 5-2, 5-3, 5-7, 5-15, 5-16
<b>HCBS REV:</b> <b>DATE:</b>	<b>F</b> <b>4-83</b>	iii thru x, 1-13, 1-14, 1-27, 1-34 thru 1-36, 2-1, 2-6 thru 2-16, 2-18, 2-20, 2-21, 2-40, 2-54 thru 2-57, 2-59 thru 2-61, 4-6 thru 4-8, 4-14, 4-16 thru 4-18, 4-20, 4-21, 4-23, 4-24, 4-31, 4-42 thru 4-140, 5-7

©

Reprinted with permission  
from ISS/SPERRY UNIVAC

# CONTENTS

		Page
<b>CHAPTER 1</b>	<b>GENERAL INFORMATION</b>	
1.1	INTRODUCTION . . . . .	1-1
1.2	SPECIFICATIONS AND CHARACTERISTICS . . . . .	1-9
1.3	GENERAL CHARACTERISTICS. . . . .	1-12
1.3.1	Head Disk Assembly (A7) . . . . .	1-12
1.3.1.1	HDA Data Surface . . . . .	1-16
1.3.1.2	HDA Servo Surface . . . . .	1-16
1.3.2	Disk Stack Rotation . . . . .	1-16
1.3.2.1	Drive Motor and Mount . . . . .	1-18
1.3.2.2	Brake. . . . .	1-18
1.3.3	Head Positioning. . . . .	1-18
1.3.3.1	Actuator Motor (EMA) . . . . .	1-18
1.3.4	Electronics Library PCAs (A1) . . . . .	1-19
1.3.4.1	Microprocessors . . . . .	1-23
1.3.4.1.1	8080 Microprocessor . . . . .	1-23
1.3.4.1.2	2901 Microprocessor . . . . .	1-23
1.3.4.2	Device Control Logic (DCL) . . . . .	1-23
1.3.4.3	Switches and Indicators . . . . .	1-23
1.3.5	Air Circulation . . . . .	1-24
1.3.6	AC Power. . . . .	1-28
1.4	HARDWARE RESOURCES . . . . .	1-28
1.4.1	Tools and Equipment . . . . .	1-28
1.4.2	Available Manuals . . . . .	1-29
1.5	MAINTENANCE PHILOSOPHY . . . . .	1-30
1.5.1	Objectives . . . . .	1-30
1.5.2	Basic Considerations of Test and Inspection . . . . .	1-30
1.5.3	Safety . . . . .	1-31
1.5.3.1	AC Power . . . . .	1-32
1.5.3.2	Cable Removal and Restoration . . . . .	1-33
1.5.3.3	Printed Circuit Assemblies . . . . .	1-34
1.5.3.4	Static Sensitive PCAs. . . . .	1-34
1.5.3.5	Controlling Static Damage In the Field . . . . .	1-35
1.5.3.6	Head Disk Assembly . . . . .	1-36
<b>CHAPTER 2</b>	<b>UNPACKAGING AND OFFLINE CHECKOUT</b>	
2.1	INTRODUCTION . . . . .	2-1
2.2	SITE PREPARATION . . . . .	2-1
2.2.1	Space Requirements . . . . .	2-1
2.2.2	Power Requirements . . . . .	2-2
2.2.3	Environmental Considerations . . . . .	2-4
2.2.3.1	Operating Environment . . . . .	2-5
2.2.3.2	Non-Operating Environment . . . . .	2-5
2.3	SHIPPING AND RECEIVING . . . . .	2-6
2.3.1	Shipping Package . . . . .	2-6
2.3.2	Unpacking . . . . .	2-7
2.3.3	Inspecting. . . . .	2-11
2.4	CABLE CONFIGURATION OVERVIEW . . . . .	2-18
2.4.1	Power Cable Configuration . . . . .	2-18

# CONTENTS

		Page
2.4.1.1	AC Power . . . . .	2-18
2.4.1.2	Ground . . . . .	2-22
2.4.1.3	Power Sequencing . . . . .	2-22
2.4.2	Massbus Cable Configuration . . . . .	2-22
2.5	POSITIONING AND ADDRESSING THE DRIVE . . . . .	2-27
2.5.1	Positioning the Drive . . . . .	2-27
2.5.2	Addressing and Jumpering . . . . .	2-27
2.5.2.1	Single Port Addressing . . . . .	2-27
2.5.2.2	Dual Port Addressing . . . . .	2-27
2.5.2.3	Drive Characteristics . . . . .	2-27
2.6	POWER VERIFICATION . . . . .	2-32
2.6.1	60 Hz Power . . . . .	2-32
2.6.2	50 Hz Power . . . . .	2-33
2.7	POWER CONVERSIONS . . . . .	2-37
2.7.1	Voltage Level Conversion . . . . .	2-37
2.7.2	Delta/Wye Conversion . . . . .	2-37
2.7.3	Frequency Conversion . . . . .	2-39
2.8	CABLE CONNECTION. . . . .	2-40
2.8.1	Power Cable Connectors . . . . .	2-41
2.8.1.1	AC Power Cable Connection . . . . .	2-41
2.8.1.2	AC Ground Cable Connection . . . . .	2-44
2.8.1.3	DC Ground Cable Connection . . . . .	2-44
2.8.1.4	Power Sequence Cable Connection . . . . .	2-44
2.8.2	Massbus Cable Connection . . . . .	2-47
2.8.2.1	Single Port Connection . . . . .	2-47
2.8.2.2	Dual Port Connection . . . . .	2-51
2.8.2.3	Massbus Grounding Requirements. . . . .	2-53
2.9	POWER OFF CHECKS. . . . .	2-53
2.10	RH CONTROLLER INFORMATION . . . . .	2-56
2.11	POWER UP . . . . .	2-56
2.12	POWER HEAD LOAD . . . . .	2-63
2.13	SUBSYSTEM SEQUENCING CHECKS . . . . .	2-63
2.14	FIELD ACCEPTANCE TESTS. . . . .	2-66
2.15	MOVING THE DRIVE AFTER INSTALLATION . . . . .	2-66
2.15.1	Moving . . . . .	2-66
2.15.2	Repacking the Drive . . . . .	2-68
 <b>CHAPTER 3 MICRODIAGNOSTICS</b>		
3.1	INTRODUCTION . . . . .	3-1
3.2	FE PANEL . . . . .	3-1
3.2.1	FE Panel Makeup . . . . .	3-1
3.2.1.1	Hexadecimal Keyboard . . . . .	3-1
3.2.1.2	LED Displays . . . . .	3-1
3.2.1.3	Mode Switch. . . . .	3-4
3.2.1.4	Reset Switch . . . . .	3-4
3.2.1.5	ENTER/STEP Switch . . . . .	3-4
3.3	PREPARING DRIVE FOR DIAGNOSTICS. . . . .	3-4

## CONTENTS (Continued)

		Page
3.3.1	Diagnostics From Host Processor . . . . .	3-4
3.3.2	Diagnostics From FE Panel . . . . .	3-5
3.3.2.1	Powering Up and/or Placing the Drive Offline . . . . .	3-5
3.4	ENTERING ROUTINES . . . . .	3-6
3.4.1	Loading A Sample Routine . . . . .	3-6
3.4.2	Errors in Loading . . . . .	3-8
3.5	MICRODIAGNOSTIC ROUTINE TYPES . . . . .	3-8
3.5.1	Summary of Microdiagnostic Routines . . . . .	3-9
3.6	MICRODIAGNOSTIC ROUTINE FLOWCHARTS . . . . .	3-40
<b>CHAPTER 4</b>	<b>REMOVAL AND REPLACEMENT</b>	
4.0	INTRODUCTION . . . . .	4-1
4.1	ASSEMBLY AND SUBASSEMBLY LOCATOR . . . . .	4-1
4.2	REMOVAL AND REPLACEMENT PROCEDURES . . . . .	4-15
4.2.1	Service Covers . . . . .	4-15
4.2.1.1	Top Cover Assembly (A4) . . . . .	4-15
4.2.1.2	Front and Rear Cover Assemblies . . . . .	4-16
4.2.1.3	Side Cover Assemblies . . . . .	4-17
4.2.2	Prefilter (P/N 9025523-00) . . . . .	4-17
4.2.3	Absolute Filter (A5A1) (P/N 9025527-01) . . . . .	4-21
4.2.4	Indicators (P/N 9412414-03) . . . . .	4-26
4.2.5	Electronics Library (A1) (P/N 9035518-03) . . . . .	4-29
4.2.6	Printed Circuit Assemblies (PCAs) . . . . .	4-33
4.2.6.1	Rectifier Assembly PCA (A1A1) . . . . .	4-38
4.2.6.2	Capacitor Assembly (A1A12) . . . . .	4-39
4.2.6.3	Pluggable Component Replacement . . . . .	4-40
4.2.7	Electronics Library Backpanel Contact Pin Replacement . . . . .	4-41
4.2.8	Head Disk Assembly (A7) . . . . .	4-41
4.2.9	Operator Control Panel Assembly/FE Panel Assembly (A1A20) . . . . .	4-70
4.2.10	EMA Magnet Assembly (A6A3A1) . . . . .	4-73
4.2.11	EMA Exhaust Filter . . . . .	4-81
4.2.12	Air Pressure Switch . . . . .	4-82
4.2.12.1	Air Hose (Air Pressure Switch) . . . . .	4-85
4.2.12.2	Air Hose (HDA/Absolute Filter) . . . . .	4-86
4.2.13	Crash Stop Assembly . . . . .	4-90
4.2.14	Blower Assembly (A5) . . . . .	4-99
4.2.15	Spindle Ground Assembly (P/N 9026235-01) . . . . .	4-105
4.2.16	Drive Motor Belt (P/N 9001856-02) . . . . .	4-110
4.2.17	Drive Motor Pulley . . . . .	4-115
4.2.18	Drive Motor Brake (A3M1L1) . . . . .	4-115
4.2.19	Drive Motor/Brake Assembly . . . . .	4-115
4.2.20	AC Power Distribution Assembly . . . . .	4-121
4.2.20.1	Line Filter . . . . .	4-124
4.2.20.2	PCA Three Phase Sense Detector . . . . .	4-127
4.2.20.3	Circuit Breaker (CB3) . . . . .	4-128
4.2.20.4	Solenoid Mercury Relay (A2K1) . . . . .	4-129



## CONTENTS (Continued)

		Page
4.2.20.5	Circuit Breaker (CB1) . . . . .	4-130
4.2.20.6	Time Meter Assembly (A2TT1) . . . . .	4-131
4.2.20.7	AC Power Distribution Assembly (A6A2) . . . . .	4-133
	Replacement	
4.2.21	Resonant Capacitor (A6A10C1) . . . . .	4-133
4.2.22	Transformer Assembly (A6A10) . . . . .	4-137
4.3	ADJUSTMENTS. . . . .	4-140

### CHAPTER 5

### PREVENTIVE MAINTENANCE

5.1	INTRODUCTION . . . . .	5-1
5.2	TOOLS AND MATERIALS REQUIRED FOR. . . . .	5-1
	PREVENTIVE MAINTENANCE	
5.3	PREVENTIVE MAINTENANCE SCHEDULE . . . . .	5-1
5.4	PREVENTIVE MAINTENANCE PROCEDURES . . . . .	5-2
5.4.1	Prefilter . . . . .	5-2
5.4.1.1	Prefilter Replacement . . . . .	5-4
5.4.2	Backpanel. . . . .	5-5
5.4.3	Cables and Harnesses . . . . .	5-6
5.4.4	Air Hoses . . . . .	5-6
5.4.5	Component, Assembly Subassembly Attaching . . . . .	5-8
	Hardware	
5.4.6	Absolute Filter . . . . .	5-8
5.4.6.1	Absolute Filter Air Pressure Check . . . . .	5-8
5.4.6.2	Absolute Filter Replacement . . . . .	5-11
5.4.6.3	Airflow Check . . . . .	5-15
5.4.7	Battery Pack Check . . . . .	5-15

### APPENDIX A

### BINARY-OCTAL-HEXADECIMAL-DECIMAL CONVERSION

A-1

### APPENDIX B

### HDA CROSS CONNECT PROCEDURE

B-1

## ILLUSTRATIONS

Figure No.	Title	Page
1-1-A	The RP07 Disk Drive .....	1-2
1-1-B	Simplified Block Diagram .....	1-3
1-1-C	Detailed Block Diagram .....	1-5
1-1-C	Detailed Block Diagram .....	1-7
1-3-A	RP07 Front View .....	1-13
1-3-B	RP07 Rear View .....	1-14
1-3-1	Head Disk Assembly .....	1-15
1-3-2	Drive Motor Assembly .....	1-17
1-3-4	Electronics Library .....	1-21
1-3-4-3-A	Operators Control Panel .....	1-24
1-3-4-3-B	FE Control Panel .....	1-25
1-3-5-A	High Pressure Air Circulation .....	1-26
1-3-5-B	Low Pressure Air Circulation .....	1-27
2-2-1-A	RP07 Dimensions .....	2-2
2-2-1-B	RP07 Service Clearances .....	2-3
2-3-2-A	RP07 Shipping Package .....	2-9
2-3-2-B	Unloading the Drive from the Pallet .....	2-13
2-3-3-A	RP07 with Service Covers Removed .....	2-15
2-3-3-B	HDA Clamp and Padding .....	2-17
2-3-3-C	EMA Cover Shield Storage During Shipping .....	2-19
2-3-3-D	Front Baseplate Block .....	2-20
2-3-3-E	Rear Baseplate Block .....	2-20
2-3-3-F	Cable Shields .....	2-21
2-4-2-A	Single Port (MASSBUS) .....	2-23
2-4-2-B	Dual Port/Dual RHXXs/Single System/Single Cabinet (MASSBUS) .....	2-24
2-4-2-C	Dual Port/Dual RHXXs/Dual System/Adjacent Cabinets (MASSBUS) .....	2-25
2-4-2-D	Dual Port/Dual RHXXs/Dual System/Dual Cabinets (MASSBUS) .....	2-26
2-5-1	Bolting the Drives Together .....	2-28
2-5-2-1-A	Drive Address Jumpers on the A1A11 PCA .....	2-28
2-5-2-1-B	Drive Address Configurations .....	2-29
2-5-2-1-C	Serial Number Connecting Links .....	2-30
2-5-2-1-D	Serial Number Connecting Links .....	2-31
2-6-1	AC Power Distribution Assembly and Transformer Assembly .....	2-32
2-6-2-A	AC Power Distribution Assembly (Exploded View) .....	2-34
2-6-2-B	AC Power Distribution Assembly (Front View) .....	2-35
2-7-2-A	50 Hz Delta Configuration .....	2-38
2-7-2-B	50 Hz Wye Configuration .....	2-38
2-8-1-1	AC Power Cable Connections .....	2-42
2-8-1-2	AC Ground Strap Connection .....	2-43
2-8-1-3	DC Ground Strap Connection .....	2-45
2-8-1-4-A	Power Sequence Plug and Cable Assembly .....	2-45
2-8-1-4-B	Power Sequence Connections on Backpanel .....	2-46
2-8-1-4-C	Sequence Cable Interconnect .....	2-46
2-8-2-A	Massbus Connector .....	2-48

## ILLUSTRATIONS (Continued)

Figure No.	Title	Page
2-8-2-B	Massbus Connector Location .....	2-49
2-8-2-1	Single Port Massbus Connection .....	2-50
2-8-2-2	Dual Port Massbus Connection .....	2-52
2-9-A	RP07 Front View .....	2-54
2-9-B	RP07 Rear View .....	2-55
2-11-A	Air Pressure Tap (Absolute Filter) .....	2-59
2-11-B	EMA and Shipping Rod .....	2-60
2-11-C	Crash Stop Indicator Arm .....	2-61
2-11-D	HDA Carriage Retainer .....	2-62
2-13-A	Cable Shields .....	2-64
2-13-B	EMA Cover Shield Installation .....	2-65
2-15	EMA and Shipping Rod .....	2-67
3-2-A	Operator Panel Assembly .....	3-2
3-3-B	FE Control Panel .....	3-3
3-6-1	Seek-Seek .....	3-41
3-4-3	Incremental Seek (RTN 11) .....	3-43
3-6-3	Random Seek (RTN 12) .....	3-45
3-6-4	Recal-Recal (RTN 13) .....	3-47
3-6-5	Tachometer Diagnostics (RTN 14) .....	3-49
3-6-6	Indicator Test (RTN 15) .....	3-51
3-6-7	FE Control Panel Test (RTN 16) .....	3-53
3-6-8	RAM Read (RTN 17) .....	3-55
3-6-9	PLO Unsafe (RTN 18) .....	3-57
3-6-10	EMA Current Reporting (RTN 19) .....	3-59
3-6-11	Index/Sector/LA Register/Unsafe (RTN 1A) .....	3-63
3-6-12	Read/Write Safety Extended (RTN 1B) .....	3-65
3-6-13	SERDES Extended (RTN 1C) .....	3-67
3-6-14	Data Encode/Decode (RTN 1D) .....	3-69
3-6-15	Read Track Descriptor (RTN 1E) .....	3-71
3-6-16	Write Null (RTN 1F) .....	3-73
3-6-17	Write/Read (RTN 20) .....	3-75
3-6-18	Read Data (RTN 21) .....	3-77
3-6-19	AM Test (RTN 22) .....	3-79
3-6-20	CROM Parity DCL Check (RTN 23) .....	3-81
3-6-21	PROM Check (RTN 24) .....	3-83
3-6-22	Register Check (RTN 25) .....	3-85
3-6-23	Interrupt Check (RTN 26) .....	3-87
3-6-24	CPU Unsafe (RTN 27) .....	3-89
3-6-25	Timer Test (RTN 28) .....	3-91
3-6-26	Bus Check (RTN 29) .....	3-93
3-6-27	Analog C (RTN 2A) .....	3-95
3-6-28	A/D Test (RTN 2B) .....	3-97
3-6-29	A/D-D/A Test (RTN 2C) .....	3-99
3-6-30	Oscillator Test (RTN 2D) .....	3-101
3-6-31	Difference Counter (RTN 2E) .....	3-103
3-6-32	Linear Mode (RTN 2F) .....	3-105
3-6-33	Cylinder Detector (RTN 30) .....	3-107

## ILLUSTRATIONS (Continued)

Figure No.	Title	Page
3-6-34	Position Channel (RTN 31) .....	3-109
3-6-35	Servo Amp (RTN 32) .....	3-111
3-6-36	Curve Generator (RTN 33) .....	3-113
3-6-37	Comm/Maint Register Test (RTN 34) .....	3-115
3-6-38	CROM Check Sum Test (RTN 35) .....	3-117
3-6-39	DCL 1 Test (RTN 36) .....	3-119
3-6-40	DCL 2 Test (RTN 37) .....	3-121
3-6-41	I/O Wrap (RTN 38) .....	3-123
3-6-42	Full Check on J12 (RTN 39) .....	3-125
3-6-43	SERDES Wrap (RTN 3A) .....	3-139
3-6-44	R/W Basic (RTN 3B) .....	3-141
3-6-45	DCL Utility for Control Signal (RTN 3C) .....	3-143
3-6-46	8080 Utility for Control Signal (RTN 3D) .....	3-145
3-6-47	Pack Spin Up Utility (RTN 3E) .....	3-145
3-6-48	Pack Spin Down Utility (RTN 3F) .....	3-145
3-6-49	CROM Read Utility (RTN 40) .....	3-147
3-6-50	Zero RAM Read (RTN 45) .....	3-147
3-6-51	Tachometer Calibration (RTN 46) .....	3-149
3-6-52	Test all Initialization Routines (RTN 47) .....	3-149
4-1-A	Assembly and Subassembly Locator .....	4-3
4-1-B	RP07 Disk Drive .....	4-5
4-1-C	Drive Service Covers .....	4-6
4-1-D	Drive Assemblies .....	4-7
4-1-E	Electronics Library and PCAs .....	4-9
4-1-F	Drive Frame Assemblies (Front View) .....	4-11
4-1-F	Drive Frame Assemblies (Rear View) .....	4-12
4-1-G	AC Power Distribution Assembly (Exploded View) .....	4-13
4-1-H	Baseplate Assembly .....	4-14
4-2-1-1	Top Cover Assembly .....	4-16
4-2-1-2	Drive Service Covers .....	4-18
4-2-2	Prefilter Replacement .....	4-19
4-2-3-A	Absolute Filter Replacement .....	4-21
4-2-3-B	Absolute Filter Air Pressure Taps .....	4-23
4-2-4	Indicator Lamps .....	4-27
4-2-5-A	Electronics Library .....	4-29
4-2-5-B	Air Pressure Switch .....	4-30
4-2-6	Electronics Library and PCAs .....	4-35
4-2-8-A	Flight Height Versus Contaminants .....	4-41
4-2-8-B1	Replacement HDA Packaging - Partial Kit .....	4-43
4-2-8-B2	Replacement HDA Packaging (To be used with partial kit) ..	4-44
4-2-8-C	HDA (Coil and Air Nozzle Dust Cap) .....	4-47
4-2-8-D	EMA (Crash Stop Indicator Arm) .....	4-48
4-2-8-E	HDA Removal .....	4-50
4-2-8-F	HDA (Carriage Retainer) .....	4-51
4-2-8-G	EMA Magnet Assembly .....	4-52
4-2-8-H	Air Hose Instalation .....	4-55
4-2-8-J	Air Hose Connection .....	4-60
4-2-8-K	EMA Filter Installation .....	4-62

## ILLUSTRATIONS (Continued)

Figure No.	Title	Page
4-2-9	Operator Control Panel Assembly/FE Panel Assembly .....	4-71
4-2-10-A	EMA Magnet Assembly .....	4-74
4-2-10-B	EMA (Crash Stop Indicator Arm) .....	4-76
4-2-10-C	HDA and Keeper Plate .....	4-77
4-2-12-A	Air Pressure Switch .....	4-82
4-2-12-B	Air Pressure Switch (Exploded View) .....	4-84
4-2-12-1-A	Absolute Filter (Air Taps) .....	4-87
4-2-12-1-B	Air Pressure Switch .....	4-87
4-2-12-2	Air Hose (HDA/Absolute Filter) .....	4-88
4-2-13-A	Crash Stop Assembly .....	4-91
4-2-13-B	Crash Stop Indicator Arm .....	4-93
4-2-13-C	Belt Extension Spring .....	4-95
4-2-14-A	Blower Assembly and Filters .....	4-100
4-2-14-B	Absolute Filter (Air Pressure Taps) .....	4-101
4-2-15-A	Spindle Ground Assembly .....	4-106
4-2-15-B	AC Power Distribution Assembly (Front View) .....	4-107
4-2-16	AC Power Distribution Assembly (Front View) .....	4-112
4-2-19-A	Drive Motor/Brake Assembly .....	4-117
4-2-19-B	AC Power Distribution Assembly (Front View) .....	4-118
4-2-20-A	AC Power Distribution Assembly .....	4-122
4-2-20-B	AC Power Distribution Assembly (Front View) .....	4-123
4-2-20-C	AC Power Distribution Assembly (Exploded View) .....	4-125
4-2-21-A	Resonant Capacitor .....	4-134
4-2-21-B	AC Power Distribution Assembly (Front View) .....	4-136
5-4-1	Drive Prefilter .....	5-3
5-4-4	RP07 Front View .....	5-7
5-4-6-1	Absolute Filter .....	5-10
5-4-6-2	Absolute Filter Replacement .....	5-12

## TABLES

Table No.	Title	Page
1-2	RP07 Disk Drive Specifications .....	1-9
1-5-3-4	Methods of Electrostatic Charge Control .....	1-35
2-5-2-3	Drive Option Jumpers .....	2-27
2-6-1	60 Hz Verification .....	2-32
2-6-2	50 Hz Verification .....	2-33
2-11-A	Voltage Readings .....	2-57
2-11-B	Minimum Air Pressure Requirements .....	2-58
3-5-1-A	Summary of Microdiagnostic Routines .....	3-9
3-5-1-B	Parameter Requirements .....	3-11
4-2-3	Air Pressure Records .....	4-25
4-2-14	Air Pressure Records .....	4-104
5-3	Preventive Maintenance Schedule .....	5-2
5-4-6-1	Air Pressure Records .....	5-11

## CHAPTER 1

### GENERAL INFORMATION

#### 1.1 INTRODUCTION

The RP07 Disk Drive, see Figure 1-1-A, is a fixed media, random access, mass storage device. It provides for storage and retrieval of data from any location on the rotating disks. The drive has a moving carriage which positions 32 read/write and 1 servo head over 17 disk surfaces having 630 customer usable cylinders and 2 FE cylinders.

Referencing the Simplified Block Diagram, Figure 1-1-B, the RP07 Disk Drive can be broken down into four functional areas:

- Read/Write - Consisting of the media, and the following PCAs: A17 (R/W Analog), A16 (R/W Safety), A15 (Data Encoder/Decoder), A14 (SERDES/ECC). This area is responsible for data handling, including encoding and decoding of data and Error Correction Code (ECC) generation.
- Analog - The A4 (Analog C), A5 (Analog B), and A6 (Analog A) PCAs contain the analog circuits which are concerned with servo positioning of the heads over a particular cylinder. In addition these PCAs contain the D/A and A/D circuits used for converting digital signals to analog signals and vice versa.
- Microprocessors - Two microprocessor systems are used in the RP07. They are the 8080 microprocessor and the 2901 microprocessor. These two processing systems monitor and control the activities of the drive. The 8080 and supporting circuits are located on the A7 (Servo Control) PCA while the 2901 system, which makes up the Device Control Logic (DCL), are located on the A9 (Device Controller 1) and A10 (Device Controller 2) PCAs.
- Massbus Interface - The Massbus interface provides the communications path between the drive, (DCL), and the RHXX controller. In addition the massbus interface contains registers which store drive status and other types of information which may be required by the host processor system or by one of the microprocessor systems. The Massbus interface circuitry is contained on the A8 (Command/Index/Sector), A11 (Massbus Interface), A12 (Interface Control), and A13 (Massbus Interface) PCAs.

Taking the block diagram of Figure 1-1-B one step farther, a more detailed version, Figure 1-1-C, shows many of the major features in each of the PCAs. Also shown are bus and control lines with the direction of flow of data indicated by the arrows.

The RP07 Disk Drive has an Operator Control Panel/FE Panel Assembly and two microprocessors (8080 and 2901) with internal microdiagnostic capabilities. A Dual Port option allows the drive to be accessed by two different RHXX controllers.

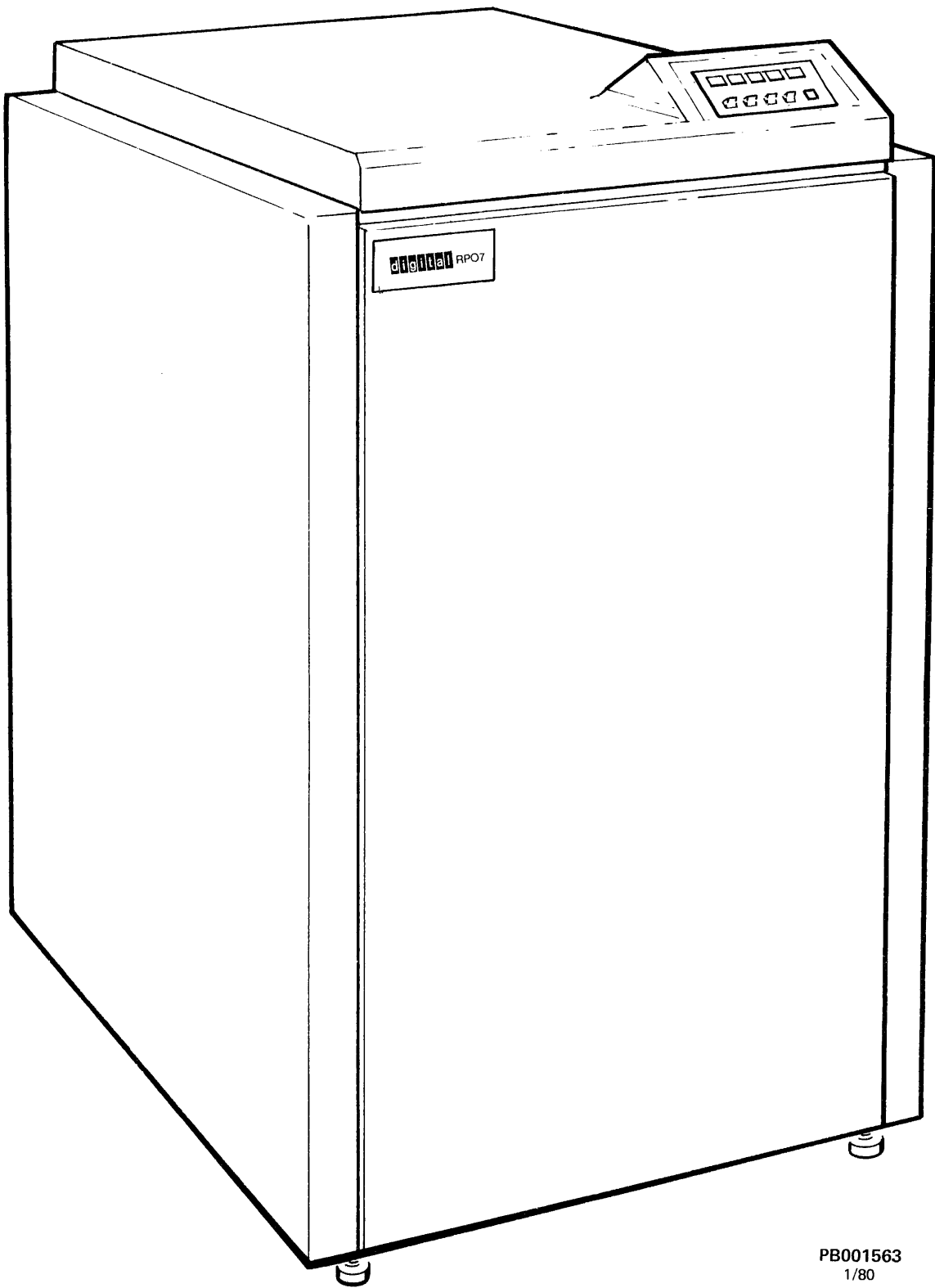

Figure 1-1-A The RP07 Disk Drive

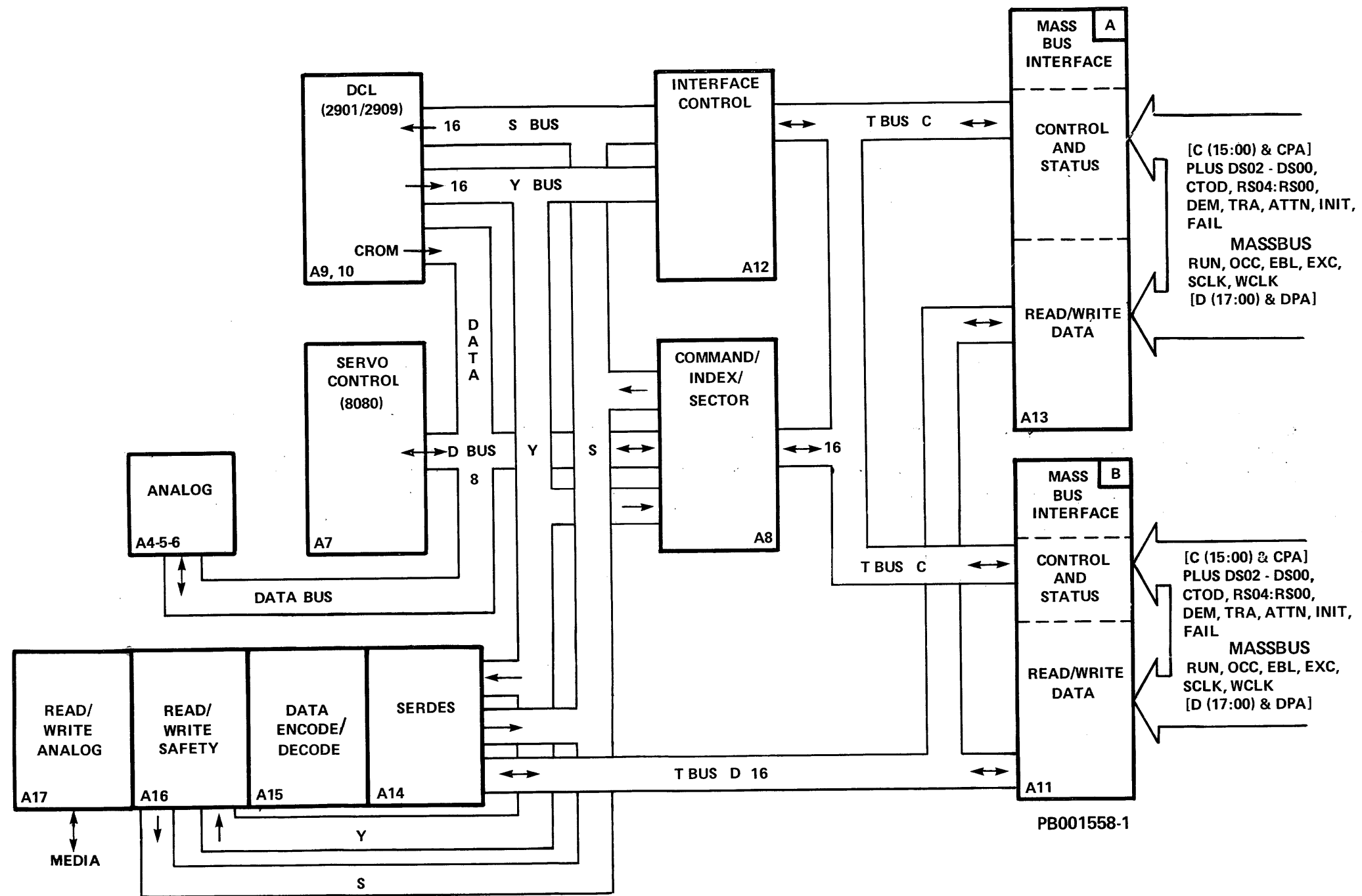

Figure 1-1-B Simplified Block Diagram



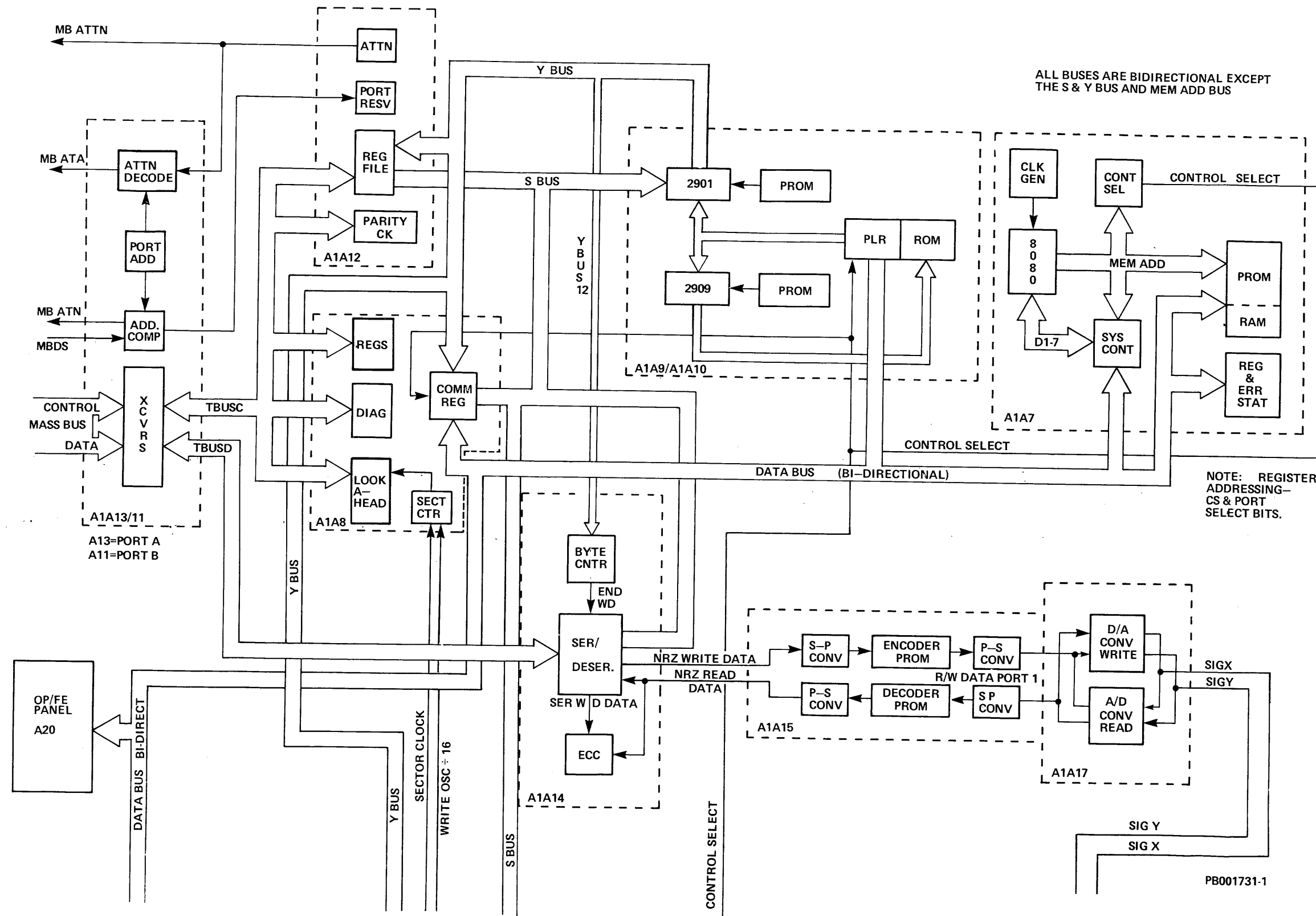

Figure 1-1-C Detailed Block Diagram  
(Sheet 1 of 2)

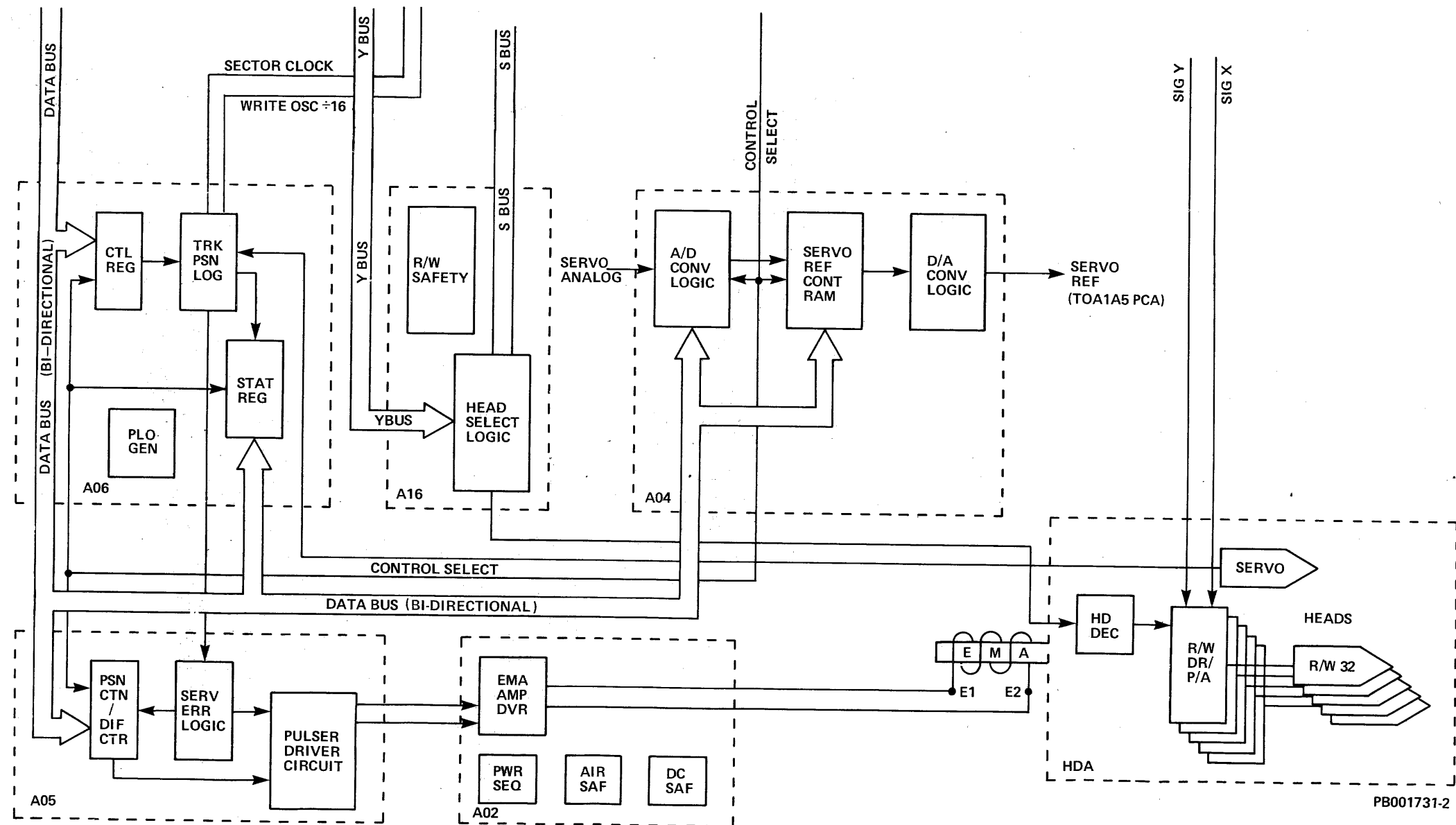

Figure 1-1-C Detailed Block Diagram  
(Sheet 2 of 2)

## 1.2 SPECIFICATIONS AND CHARACTERISTICS

Drive specifications and characteristics are listed in Table 1-2.

Table 1-2 RP07 Disk Drive Specifications

### OPERATION:

Start-up time, (CB1 ON to heads on cylinder 000)	82 seconds $\pm$ 3 seconds
Disk rotation	3633 RPM $\pm$ 3%
Spindle stop time	20 sec

### DISK STACK:

Disk diameter	35.56 cm (14")
Number of disks	9
Data recording surfaces	16
Servo recording surface	1

### READ/WRITE:

Number of Read/Write heads	32
Cylinders per disk stack	2X(630 + 2 FE cylinders) = 1260 + 4 FE cylinders total
Tracks per cylinder	32
Tracks per inch	537 (nominal)
Total tracks per disk stack	20,160 + 64 FE Tracks
Data bytes per track max	
16 bit mode (50 sectors/TK)	
Sector capacity	256 words; 512 bytes
Track capacity	12,800 words; 25,600 bytes
18 bit mode (43 sectors/TK)	
Sector capacity	256 words; 576 bytes
Track capacity	11,008 words; 24,768 bytes
Stack capacity	
16 bit mode (50 sectors/TK)	258 megawords; 516 megabytes
18 bit mode (43 sectors/TK)	221 megawords; 499.3 megabytes

Table 1-2 RP07 Disk Drive Specifications (Continued)

Data transfer rate	
Interleaved sectors	1.3 megabytes/second max (128 word max buffer - 16 or 18 bit mode)
Non-interleaved sectors	2.16 megabytes/second max (16 bit mode) 1.92 megabytes/second max (18 bit mode)
Recording density--in bits per inch (linear)	11,139 BPI on inner track (nominal)

**ENVIRONMENT:**

Operating temperature range	15°C (59°F) to 32°C (90°F) with max change of 6.6°C (12°F) per hour
Operating humidity range	20%-80% with max wet bulb of 25°C (77°F)
Shipping temperature range	-40°C (-40°F) to +66°C (+151°F) with max change of 14°F/hour
Shipping humidity range	5% to 90%
Drive cooling (internal)	No external forced air is necessary
Heat Dissipation	7000 BTU/Hour (2.051 KW)
Altitude Range - Operating (Normal)	Sea level to 2400 M (sea level to 8000 feet)

**POWER REQUIREMENT:**

<u>TYPE</u> <u>3 VOLTAGE</u> <u>TAPS</u>	<u>FREQUENCY</u> <u>TOLERANCE</u>	<u>NOMINAL</u> <u>OR TAP</u> <u>VOLTAGE</u>	<u>VOLTAGE</u> <u>RANGE</u>
60 Hz	+2%	200/208	170-220
60 Hz	+2%	220	184-236
60 Hz	+2%	240	201-256
50 Hz	+2%	200/208	170-220
50 Hz	+2%	220	184-236
50 Hz	+2%	240	201-256

Table 1-2 RP07 Disk Drive (Continued)

Starting current surge	55 amps (max)
Running current	8 amps (max)

**PHYSICAL DIMENSIONS OF CABINET:**

Height	118.1 cm (46.5")
Width	57.15 cm (22.5") without side covers 62.23 cm (24.5") with one side cover 67.31 cm (26.5") with two side covers
Depth	83.82 cm (33.0")
Mounting	Adjustable levelers (casters also provided)
Weight	Approximately 181.44 kg (400 lbs) total
Floor loading	382 kg/m <sup>2</sup> (78 lbs per square foot)

**RECOMMENDED CLEARANCES:**

Front	71 cm (28") minimum
Rear	71 cm (28") minimum
Side	0" without side covers
Side	31 cm (12") with side covers

**Characteristics**

**ACCESSING:**

Access drive motor	Electromagnetic actuator
Access control	Microprocessor controlled. Closed-loop track following and positioning
Direct access motion:	
Coarse positioning mode	Initially moves heads to desired cylinder
Fine positioning mode	Maintains heads on desired cylinder
Access times:	
One cylinder seek	5 milliseconds (maximum)
Average seek	23 milliseconds
Maximum seek	46 milliseconds
Average rotational latency time	8.26 milliseconds
Maximum rotational latency time	16.52 milliseconds

### 1.3 GENERAL CHARACTERISTICS

Refer to Figures 1-3-A and 1-3-B.

The RP07 Disk Drive has electrical and mechanical subsystems which:

- Convert AC input power into DC voltages required by the drive
- Provide forced air cooling within the drive
- Retract, load or position the read/write heads for processing data on the disks
- Provide safety interlocks which protect the drive and the data integrity from human error
- Provide interface control between the Massbus and the disk drive
- Provide functional and microdiagnostic programs through resident microprocessors, for operation and microdiagnostic troubleshooting of the drive

The following main assemblies and functions are interrelated and are described in this chapter:

- Head/Disk Assembly - Including HDA data surface, HDA servo surface (see Subsection 1.3.1)
- Disk Stack Rotation - Including drive motor, mount, and brake (see Subsection 1.3.2)
- Head Positioning - Including actuator motor (see Subsection 1.3.3)
- Electronics Library - Including 8080 and 2901 microprocessors; device Control Logic, and Switches/Indicators (see Subsection 1.3.4)
- Air Circulation - (see Subsection 1.3.5)
- AC Power - (see Subsection 1.3.6)

#### 1.3.1 Head Disk Assembly (A7)

The Head Disk Assembly (HDA) is a sealed unit weighing approximately 15.7 kg (35 pounds). Although the HDA can be removed from the drive and replaced by a Field Engineer, no HDA maintenance or parts replacement can be performed.

The HDA (see Figure 1-3-1) consists of the following:

1. SPINDLE/DISK ASSEMBLY - Nine (9) disks, coated on each side with magnetic-oriented ferric oxide and lubricant which permits the moving heads to soft-land on and take off from the disk surfaces. The nine disks (eighteen disk surfaces) are stack mounted on a common spindle which rotates (counterclockwise) at 3633 RPM.
2. CARRIAGE ASSEMBLY - Comprised of nine (9) moving head/arm assemblies (eight 4-head assemblies and one Servo head/arm assembly). These

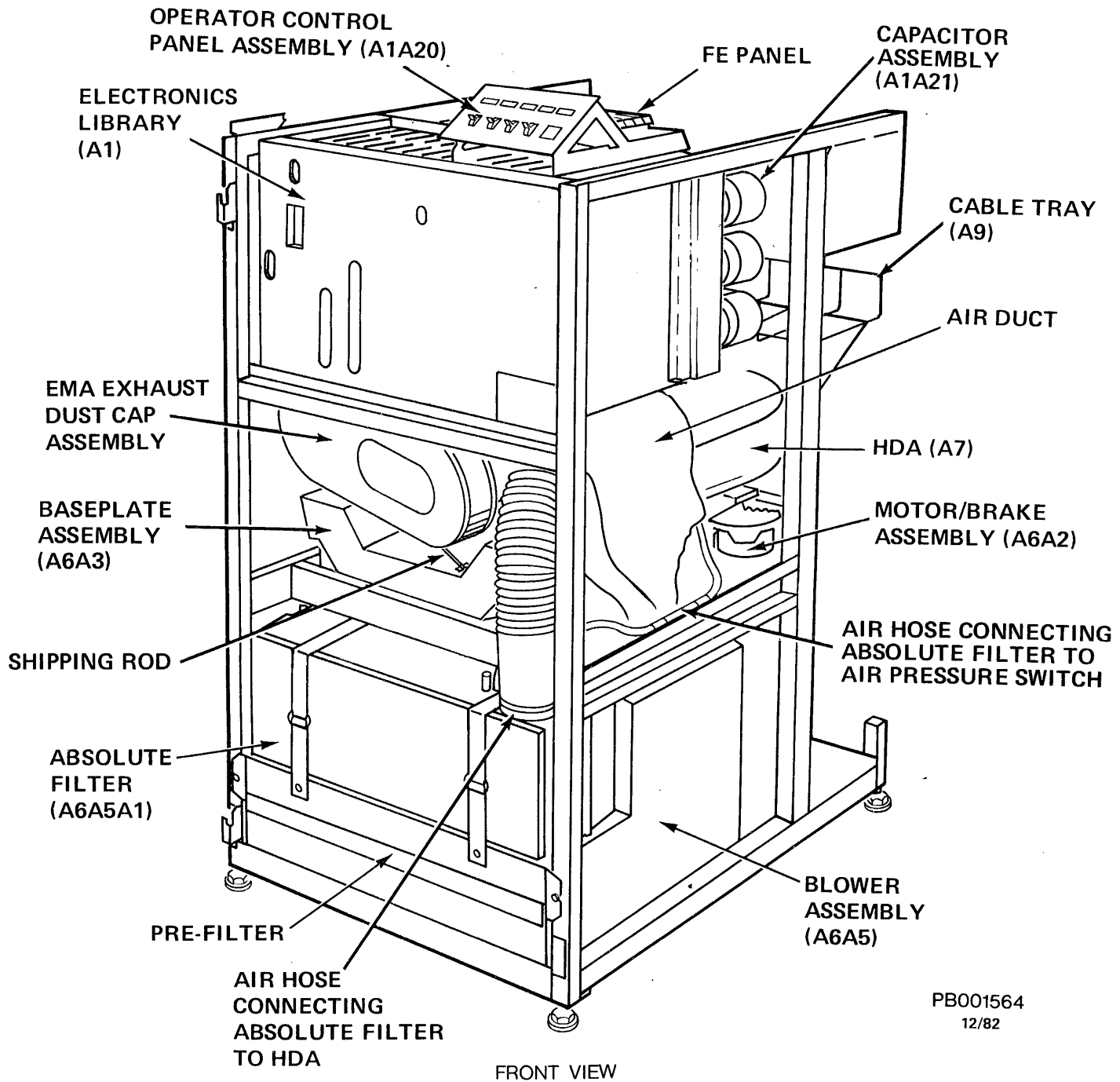
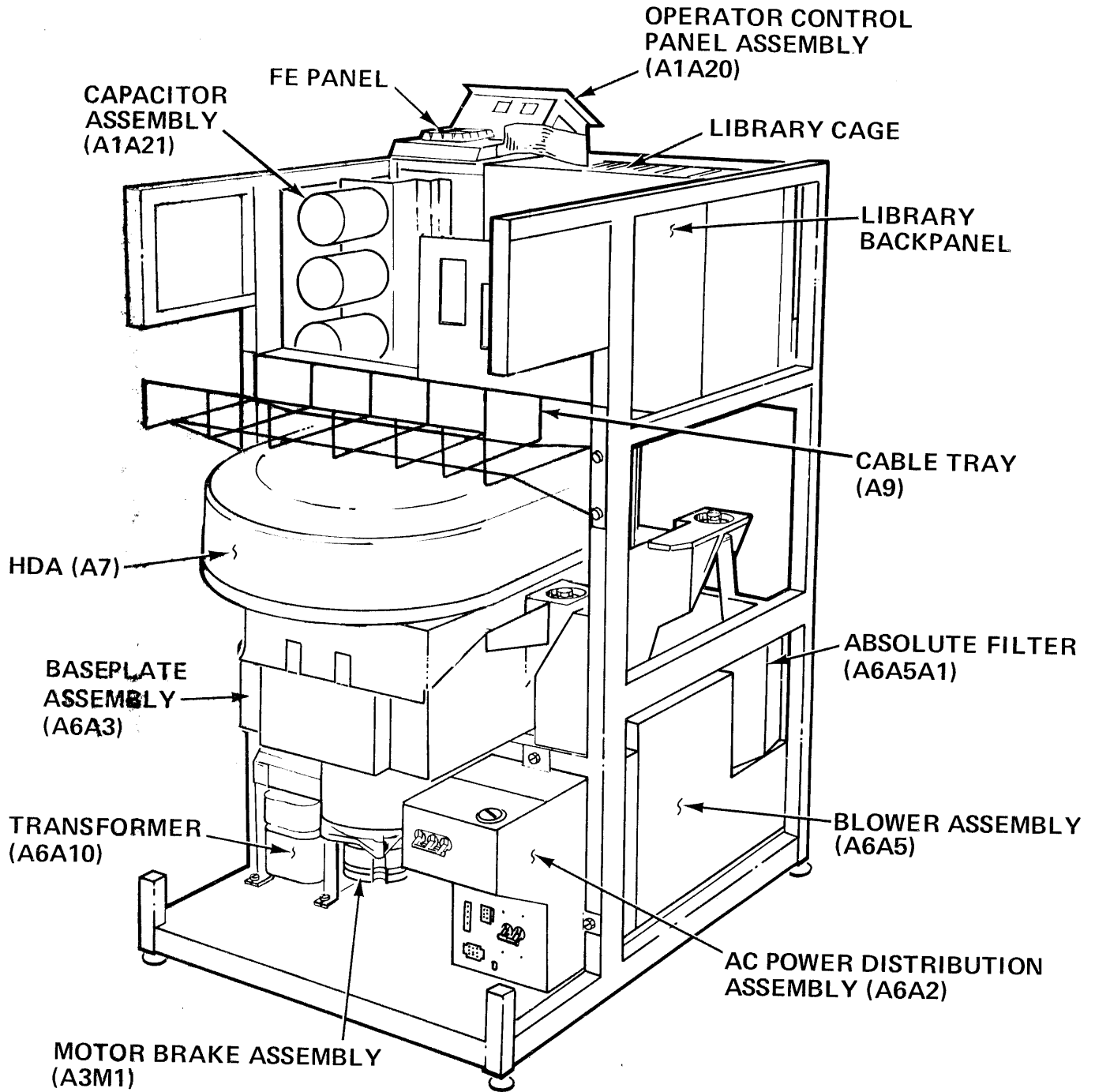

Figure 1-3-A RP07 Front View



PB001565-1  
12/82

Figure 1-3-B RP07 Rear View



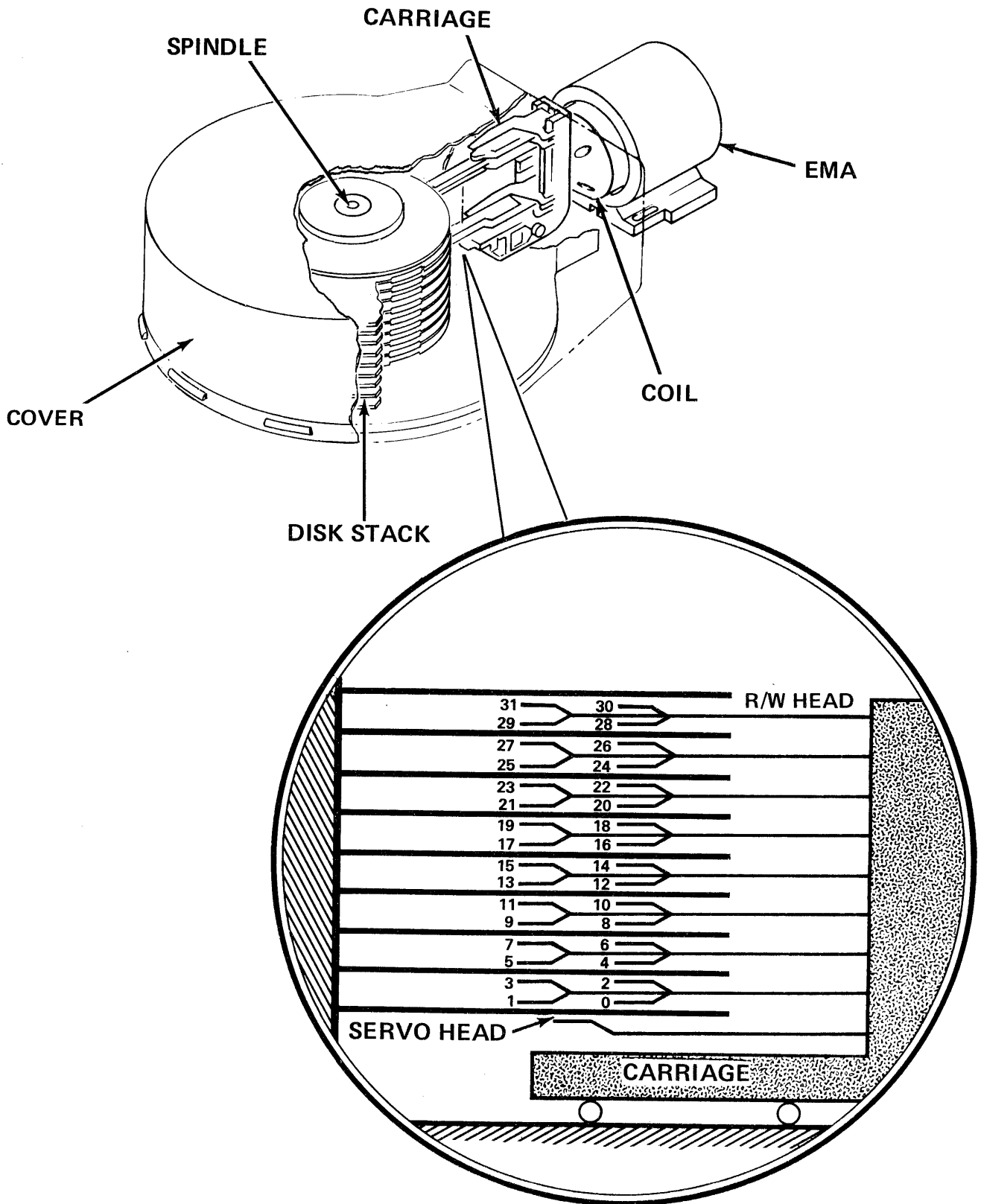

Figure 1-3-1 Head Disk Assembly

PB001602  
12-79

2. **CARRIAGE ASSEMBLY** - Comprised of nine (9) moving head/arm assemblies (eight 4-head assemblies and one Servo head/arm assembly). These nine assemblies are mounted on a moving carriage assembly. Each of the head/arm assemblies contains a linear addressable 4-channel R/W amplifier-driver chip.
3. **COIL ASSEMBLY** - Secured within the HDA cover to the rear of the carriage assembly and protrudes through the hole of the HDA faceplate. Current pulses passing through the coil assembly control the speed, direction, and position of the coil and carriage.
4. **COVER** - An enclosure (which encases the above parts) consists of an opaque plastic and metal housing effectively sealing out contaminants. This casing is supplied with pressurized, filtered air from the air circulation system whenever AC power is applied.

**1.3.1.1 HDA Data Surface** - Each data surface of the HDA contains two data areas. Each area is divided into cylinders numbered from 0 through 629, counting from the outside cylinder to the inside cylinder. Cylinders 0 through 629 are assigned as customer data areas. There are two additional cylinders, numbered 630 and 631, which are designated FE cylinders.

Headers are recorded on all data tracks during the format operation for track identification, seek verification, and skip displacement information.

There are two track formats available in the RP07 drive:

- 16-bit mode
- 18-bit mode

In the 16-bit mode, each track can accommodate 50 sectors, numbered 00 through 49. In the 18-bit mode, each track can accommodate 43 sectors, numbered 00 through 42. The two modes (16 and 18), produce format differences in the number of bytes in their data fields.

Mode	Bytes
16	512
18	576

The data field always consists of 256 words of data regardless of the drive mode.

**1.3.1.2 HDA Servo Surface** - The servo surface is composed of servo data tracks which are prerecorded for use in seeking, track following, data clocking, index point signal generation and guard band detection.

### **1.3.2 Disk Stack Rotation**

Refer to Figure 1-3-2.

The disk stack rotation system of the RP07 drive, consists of the following:

1. A double-ended three phase drive motor with an attached electromagnetic brake on the bottom end and a pulley on the top.

OLD DIAGRAM  
 REMOVE THE  
 BELT TROUGH  
 THE MOTOR (BOTTOM  
 OF THE DRIVE)  
 INSTEAD OF PULLING UP.

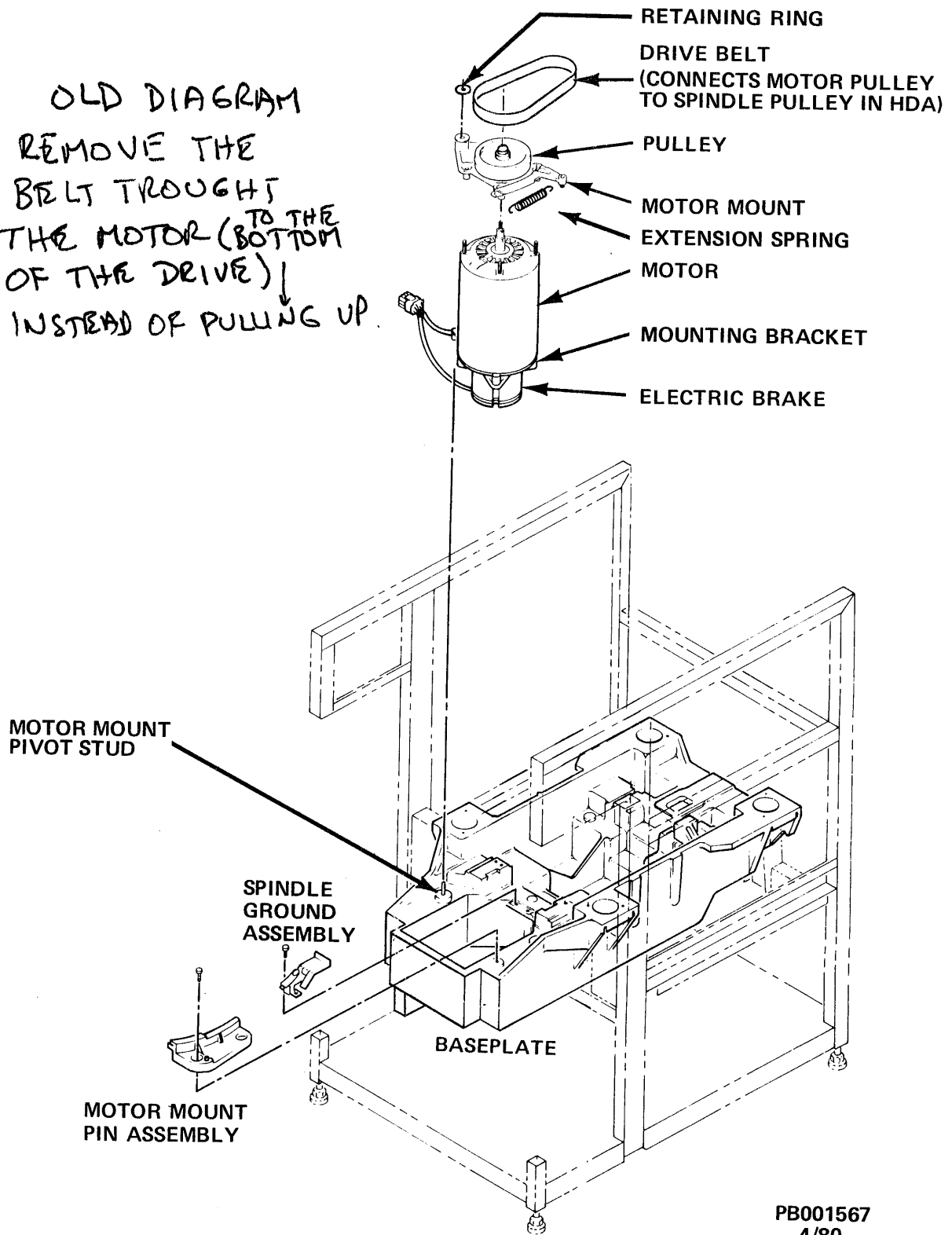

Figure 1-3-2 Drive Motor Assembly

2. A disk spindle and bearing assembly with an attached pulley (part of the HDA).
3. A drive belt connecting the motor pulley to the spindle pulley.
4. A two-piece motor mount and spring assembly to maintain tension on the drive belt.

The disk stack rotation system in the RP07 is actuated by a mercury relay located in the AC Power Distribution Assembly (A6A2). This relay is controlled by the drive's 8080 microprocessor.

**1.3.2.1 Drive Motor and Mount** - The RP07 uses a three-phase drive motor. It is vertically mounted on a pivoting aluminum motor guide, the free end of which rides in a Delrin guide fixed to the baseplate. The drive pulley is clamped to the shaft of the motor. Belt tension is maintained by an extension spring attached between the motor mount and a pin on the motor mount pin assembly. Motor speed and pulleys are matched to turn the disk stack at 3633 RPM.

**1.3.2.2 Brake** - The electromagnetic brake housing is attached to a bracket mounted to the bottom end of the drive motor. The brake armature is locked to the lower end of the drive motor shaft. When the drive spindle is not turning, the brake armature is spring-engaged with the friction disk of the brake housing. When the spindle drive motor relay is energized, the brake magnet is energized in parallel and the armature disengages the friction disk, allowing the motor shaft to rotate and turn the spindle.

### **1.3.3 Head Positioning**

The read/write heads and the servo head of the RP07 drive are attached to the head/arm assemblies of the carriage. When the servo head is on cylinder, all the data heads are aligned on cylinder.

The servo system is composed of:

1. The position subsystem - Provides accurate cylinder position information for the servo.
2. The tachometer circuit - Reports the carriage velocity to the servo.
3. The power driver subsystem - Is responsible for providing current flow to the EMA.
4. The EMA - Translates current flow into a linear movement for positioning the read/write heads to a desired cylinder.
5. The servo control subsystem - Interconnects, controls and monitors the various servo requirements.

**1.3.3.1 Actuator Motor (EMA)** - The EMA, or Electromagnetic Actuator is the assembly that provides the motive force to move the carriage in the HDA. The EMA is a fixed, permanent magnet assembly mounted on the baseplate. The moving coil protrudes through a hole in the rear of the HDA and into the EMA assembly. Current pulses coming from the Pulser/Driver circuitry are fed to the coil through a flexible lead, controlling the direction and intensity of the electromagnetic field which in turn controls the position of the carriage.

#### **1.3.4 Electronics Library PCAs (A1)**

The Electronics Library of the RP07 drive is located above the EMA and toward the front of the drive. It contains all the circuits necessary to control drive operation. The Electronics Library contains the following pluggable assemblies (see Figure 1-3-4).

- RECTIFIER ASSEMBLY (A01) - Develops unregulated DC voltages from the AC transformer output.
- EMA DRIVER/SEQUENCER (A02) - Generates pulsing current for driving the coil in either the forward or reverse direction; also contains DC safety circuits and sequencing hardware.
- POWER REGULATOR (A03) - Regulates DC voltages and maintains them within specific tolerances.
- ANALOG BOARDS A (A06), B (A05), and C (A04) - Develops analog signals from digital signals for the EMA Driver (digital signals are developed by the 8080 microprocessor), and develops digital and timing signals from analog signals generated within the HDA.
- SERVO CONTROL (A07) - Contains the 8080 microprocessor system which controls basic drive operations.
- COMMAND/INDEX/SECTOR (A08) - Communicates data between the 8080 microprocessor and 2901 microprocessor.
- DEVICE CONTROL LOGIC #1 AND #2 (A09, A10) - Contains the 2901 microprocessor system which controls command and data transfer between the host system and the drive.
- MASSBUS INTERFACE (A13, Option A11) - Receives and transmits data to and from the host system, and is controlled by the Interface Control PCA (A12). Two PCAs are used in the dual RHXX controller interface configuration.
- INTERFACE CONTROL (A12) - Receives and transmits the incoming /outgoing control signals via the Massbus Interface, and controls the drive interface logic.
- SERDES/ECC (A14) - Serializes data for write operations or deserializes data for read operations. It also performs ECC generation and checking.
- DATA ENCODER/DECODER (A15) - Encodes and decodes data for the read/write operations.
- READ/WRITE SAFETY (A16) - Contains Head Address Register, Head Select Logic, and read/write safety circuits.
- READ/WRITE ANALOG (A17) - Contains the read analog circuits and write data current source.



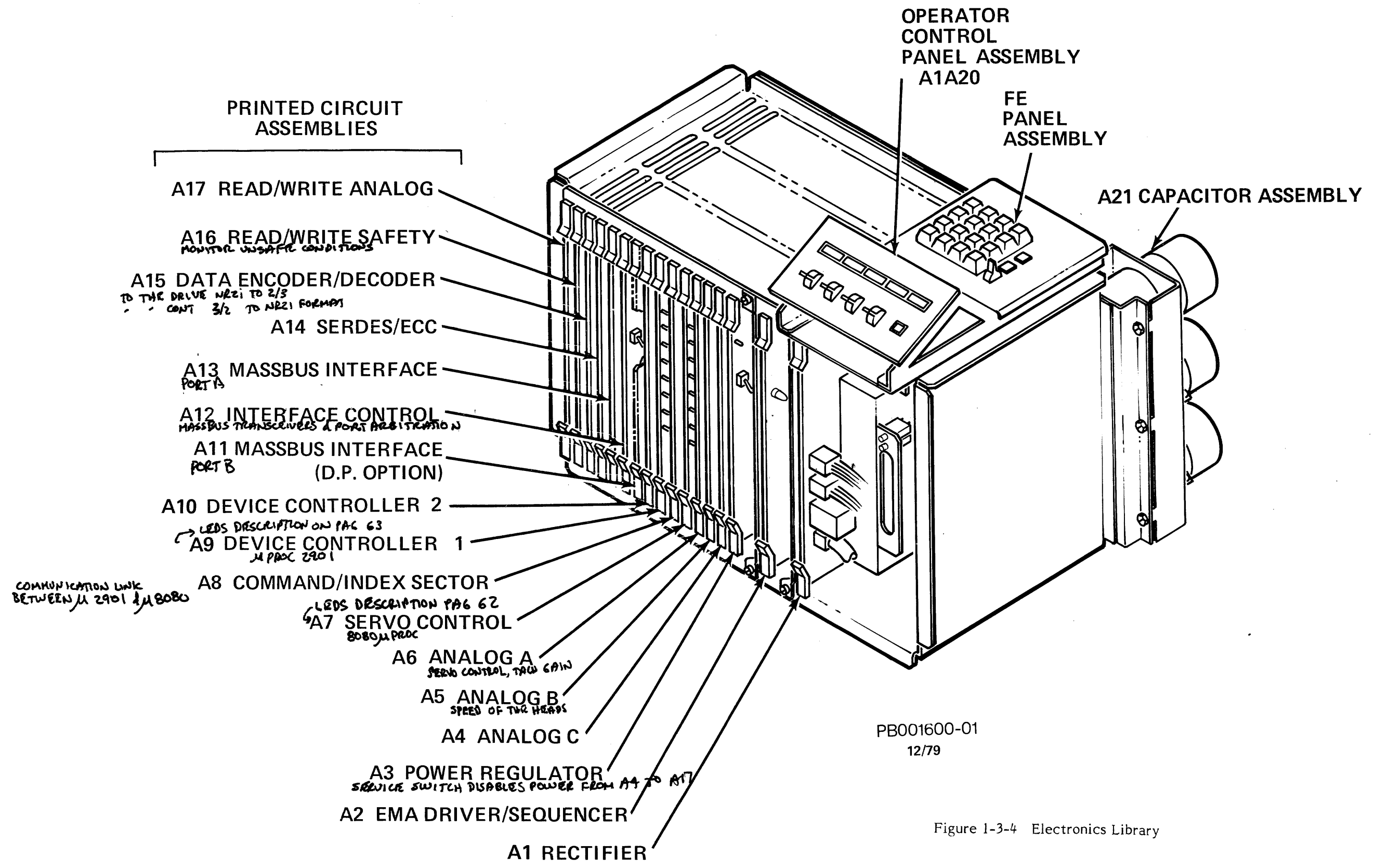

Figure 1-3-4 Electronics Library

Associated with the Electronics Library are the:

- CAPACITOR ASSEMBLY (A21) - Contains capacitors used for filtering DC voltages.
- OPERATOR CONTROL PANEL ASSEMBLY (A20) - Contains switches and indicators for operating and diagnosing the drive.

**1.3.4.1 Microprocessors** - The RP07 Disk Drive contains two microprocessing units: the 8080 microprocessor which controls drive functions and the 2901 microprocessor which executes the command and data handling from the Massbus. Both microprocessors have associated functional and microdiagnostic firmware stored in PROMs located on PCAs (A07, A09 and A10) in the Electronics Library.

**1.3.4.1.1 8080 Microprocessor** - The 8080 microprocessor, with its functional and microdiagnostic firmware, directs the basic functions of the drive:

- Initiation and control of all servo operations
- All power sequencing
- Operator and FE Control Panel interface and control
- Calibration of selected analog signals

In addition, the 8080 controls the 2901 in microdiagnostic mode and accepts commands from the 2901 in normal mode via the A08 PCA (Command/Index/Sector). The 8080 microprocessor provides limited error recovery and internal error logging for microdiagnostic purposes.

**1.3.4.1.2 2901 Microprocessor** - The 2901 microprocessor (which is part of the Device Control Logic #1 A09) is responsible for the decoding and execution of Massbus commands:

- Seek
- Search
- Data transfer/format
- Dual Port accessing

The 2901 receives the command data and status data from the Massbus for execution. The 2901 microdiagnostics are run during the initialization operation under control of the 8080.

**1.3.4.2 Device Control Logic (DCL)** - The DCL interprets the Massbus control input/output commands. DCL provides an interface between Massbus and the 8080.

**1.3.4.3 Switches and Indicators** - Mounted on top of the electronics library (cage) is the Operator Control Panel Assembly (A1A20). This assembly consists of two separate and distinct control panels, the Operator Control Panel (see Figure 1-3-4-3-A), and FE Control Panel (see Figure 1-3-4-3-B).

The Operator Control Panel, accessible from the outside of the drive, consists of switches that operate the drive, and indicators that inform the drive operator of states (drive status) within the drive.



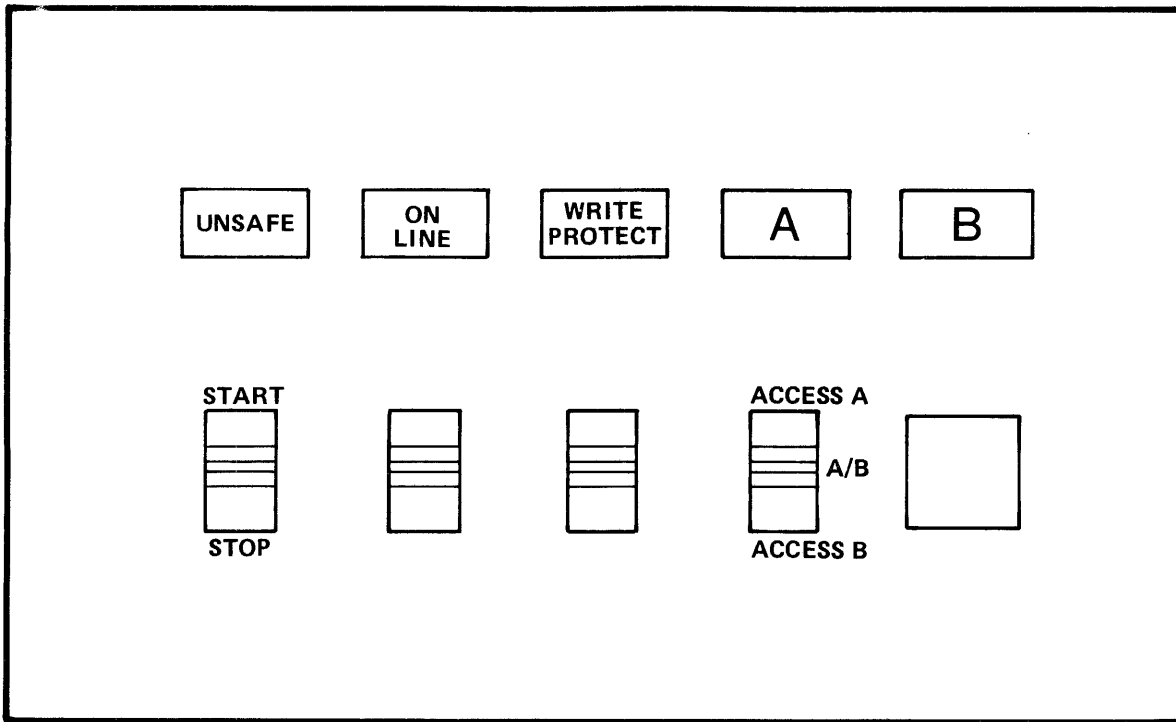

PB001561-1

Figure 1-3-4-3-A Operators Control Panel

The FE Control Panel, accessible only when the drive top cover is open, is used by the Field Engineer to monitor and perform certain functional operations within the drive. Through an interface with the 8080 microprocessor, the FE Panel allows the initiation of internal microdiagnostics, utility, and exercise routines.

The following functions can be performed by the Field Engineer by placing the drive in local microdiagnostic mode:

- Monitor functional operation
- Display drive or internal error log (this information is also available to the Massbus)
- Control and monitor all internal microdiagnostic, utilities and exerciser routines resident in the drive

### 1.3.5 Air Circulation

The air circulation system of the RP07 drive consists of a Blower Assembly (A5), which contains a three phase motor with two squirrel cage fans (not field-replaceable), a prefilter, and an Absolute Filter (A5A1).

The purpose of the air circulation system is to supply contaminant-free forced air for:

- Pressurization of the HDA (internal or external contaminants will be forced out instead of pulled into the HDA)

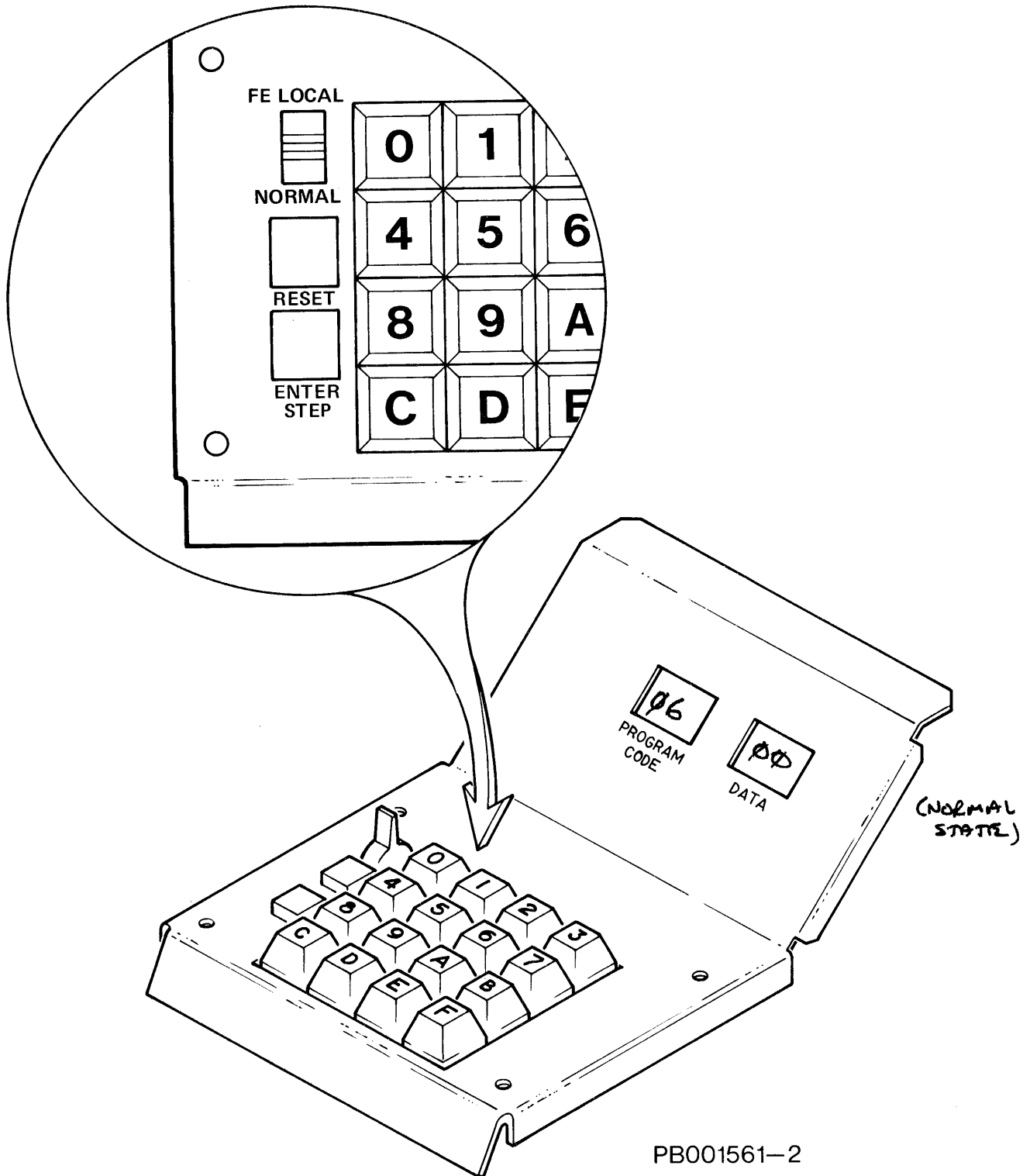

PB001561-2

Figure 1-3-4-3-B FE Control Panel

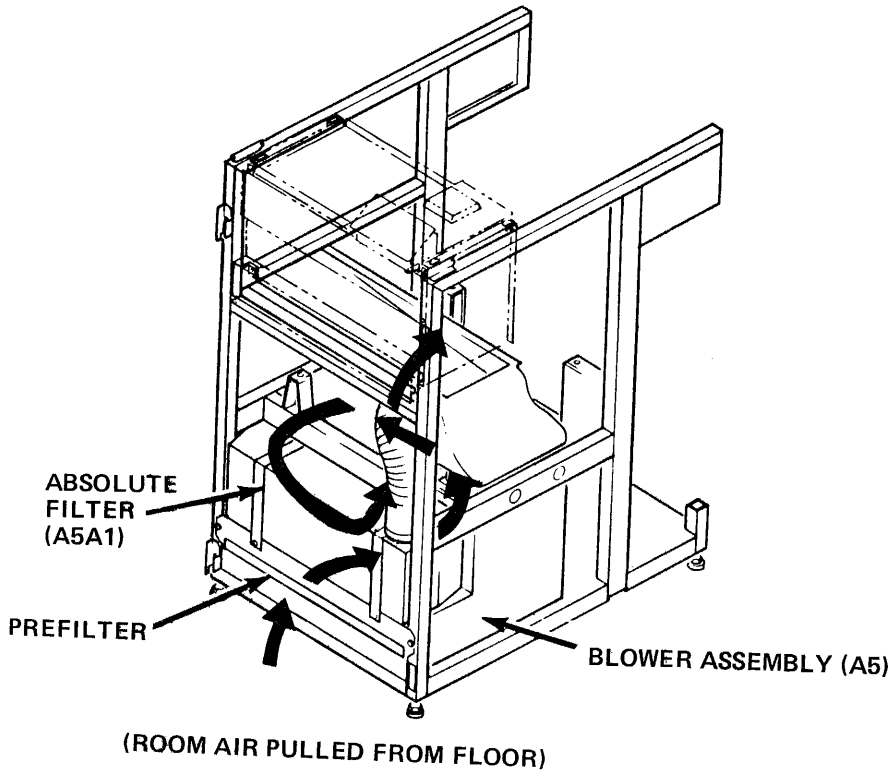

FRONT VIEW

PB001566-1

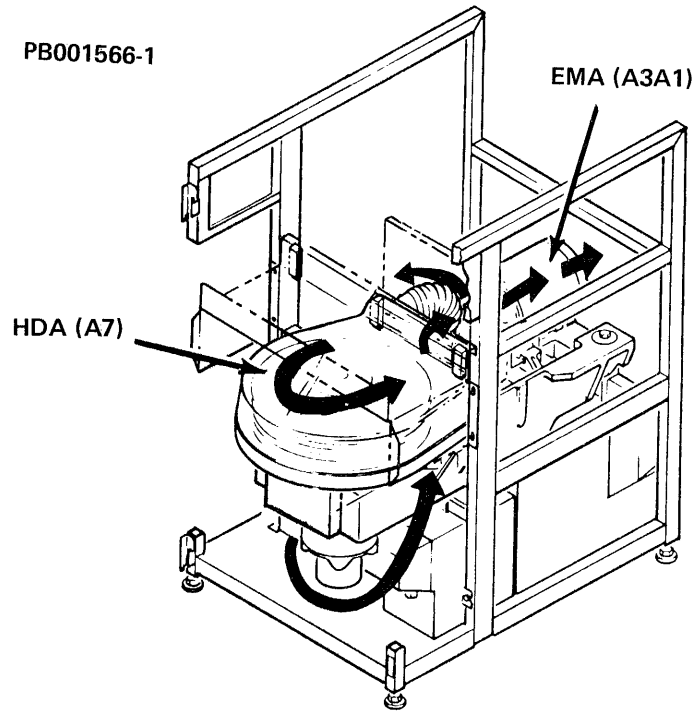

REAR VIEW

PB001566-2  
4/80

Figure 1-3-5-A High Pressure Air Circulation

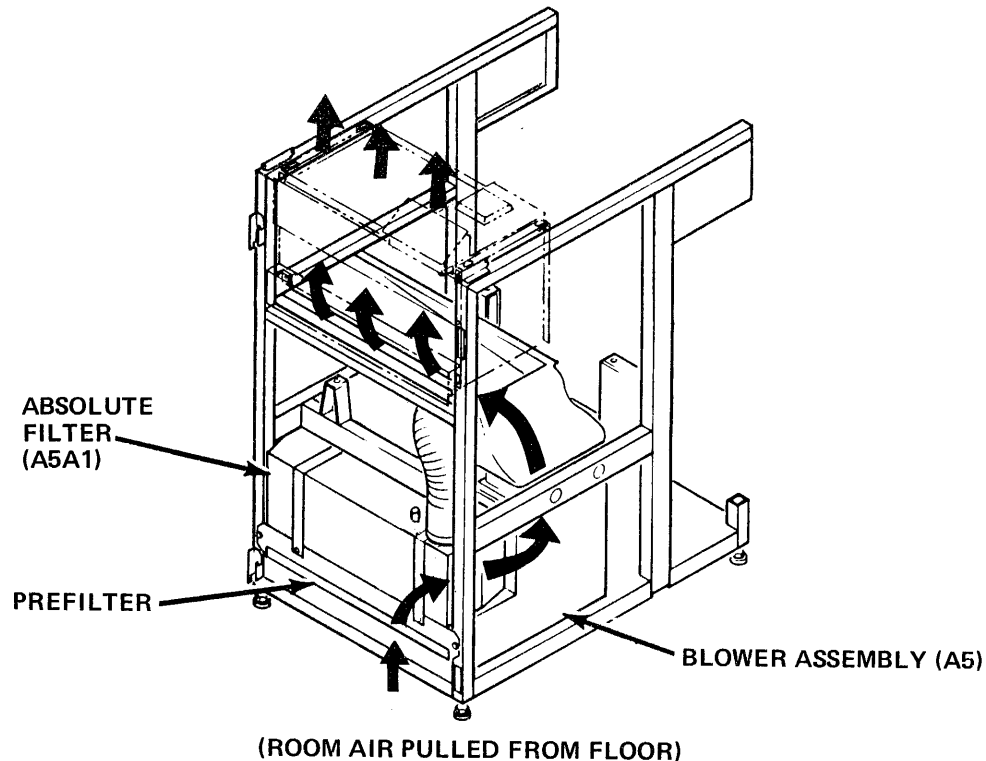

FRONT VIEW PB001566-3

Figure 1-3-5-B Low Pressure Air Circulation

- Disk stack temperature control
- EMA temperature control
- Cooling air for the PCAs and Electronics Library

Room air is pulled from around the base of the drive and into the drive by vacuum created by the air system blower. It passes through a prefilter which traps the larger airborne particles, preventing them from circulating through the Electronics Library (A1) or the Absolute Filter. The Absolute Filter effectively traps the remainder of the particles creating an essentially contaminant-free environment in the HDA (see Figure 1-3-5-A).

There are two squirrel cage fans (not field-replaceable), one of which forces low pressure air directly to the Electronics Library (via an airduct), thus providing cooling for the PCAs (see Figure 1-3-5-B).

The other fan forces high pressure air through the Absolute Filter to the HDA (via an airhose). The highly filtered air is distributed through the disk area and forced out an opening in the HDA and into the EMA (A3A1) area. The air entering into the EMA area is still pressurized, providing a cooling air stream over the actuator coil. The air is then exhausted through holes in the rear of the actuator magnet and EMA Exhaust Filter.

### 1.3.6 AC Power

The RP07 Disk Drive requires three-phase AC input power. Up to three drives may be strung together using the input three-phase AC power source with one AC power cable.

For more information pertaining to AC power, see Chapter 3 of the RP07 Technical Description Manual (ER-0RP07-TD).

<u>TYPE 3 Voltage Taps</u>	<u>FREQUENCY TOLERANCE</u>	<u>NOMINAL OR TAP VOLTAGE</u>	<u>TERMINAL TAP (TB1)</u>	<u>VOLTAGE RANGE</u>
60 Hz	$\pm 2\%$	200/208	2	170-220
60 Hz	$\pm 2\%$	220	3	184-236
60 Hz	$\pm 2\%$	240	4	201-256
50 Hz	$\pm 2\%$	200/208	2	170-220
50 Hz	$\pm 2\%$	220	3	184-236
50 Hz	$\pm 2\%$	240	4	201-256

<u>TYPE 3 Voltage Taps</u>	<u>FREQUENCY TOLERANCE</u>	<u>NOMINAL OR TAP VOLTAGE</u>	<u>TERMINAL TAP (TB1)</u>	<u>VOLTAGE RANGE</u>
60 Hz	$\pm 2\%$	200/208	2	170-220
60 Hz	$\pm 2\%$	220	3	184-236

## 1.4 HARDWARE RESOURCES

The RP07 Disk Drive is uniquely designed to allow the Field Engineer (FE) ease in serviceability. Subsection 1.4.1 of this manual describes the standard test equipment as well of the recommended optional tools and test equipment used for servicing the RP07 drive.

The complement of manuals and related documents available for the RP07 drive are listed in Subsection 1.4.2 of this manual.

### 1.4.1 Tools and Equipment

This section describes the tools and test equipment, both standard and specialized, used for servicing the RP07 drive.

#### STANDARD TEST EQUIPMENT:

The standard test equipment required for servicing and troubleshooting the RP07 drive is as follows:

1. Oscilloscope with three probes - Should be dual-trace, with minimum bandwidth of 100 MHz, minimum rise time of four nanoseconds, and a vertical deflection factor of 5 mv/cm. (Tektronix Model 465 and Hewlett Packard Model 1740-A oscilloscopes meet these specifications.)

2. Volt Ohm Meter (VOM) - meter requirements are not critical, but the meter selected should be of sufficient quality to meet the following specifications:

DC Volts	0 to 100 $\pm 2\%$
AC Volts	0 to 250 $+5\%$ (0 to 450 $\pm 5\%$ for 50 Hz sites)
Resistance	0 to 20 Megohms $\pm 5\%$
Sensitivity DC	20,000 Ohms/Volt
Sensitivity AC	10,000 Ohms/Volt

#### OPTIONAL TOOLS:

1. Air Nozzle Cap (for capping the HDA air nozzle)
2. Dust Cap (for capping the HDA coil) - The Air Nozzle and HDA Dust Caps inhibit contamination of a removed HDA. Both caps come installed on a replacement HDA.
3. A PCA Extender - The PCA Extender is used for extended analysis or component-level repair. It is recommended that it be stocked only at larger sites, branch or regional levels.
4. Digital Volt Meter - Meter requirements are not critical, but the meter selected should be of sufficient quality to meet the following specifications: 3-1/2 digits or more; should have accuracy of  $\pm 1$  percent for checking drive power supply voltage.

A Lamp Remover/Inserter tool used for the removal and replacement of the Operator Control Panel with incandescent lamps, and a shipping rod used during drive relocation, are supplied with every RP07 drive. (See Illustrated Parts Breakdown (ER-0RP07-IP) for part number requirements.)

#### OPTIONAL (SPECIAL) TEST EQUIPMENT:

1. Air Measuring Kit (DEC P/N 29-21290-00)
2. Adapter Hose

The Air Measuring Kit and Adapter Hose are optional test equipment used for checking the Absolute Filter air pressure.

3. Biomation Logic State Analyzer Model 1650-D with Data Domain or an equivalent.

#### 1.4.2 Available Manuals

The following publications are related documents for the RP07 Disk Drive. An asterisk (\*) denotes the documents shipped with the drive.

## User's Guide - ER-0RP07-UG\*

This manual provides drive specifications and characteristics, site preparation and layout, unpacking and installation information, plus hardware resources that include tool and test equipment requirements. It also provides a preventive maintenance schedule with procedures. Operational sequences and operation of the Operator Control Panel is also included.

## Field Maintenance Print Set - ER-0RP07-MP\*

This manual contains wiring diagrams, assembly, logic, and schematic prints. Functional area block diagrams with Print Set references are also provided.

## Technical Description Manual - ER-0RP07-TD

This manual explains how the drive functions, and provides troubleshooting reference information. Detailed block diagrams, sequence flowcharts, and timing diagrams are also included.

## Service Manual - ER-0RP07-SV

This manual provides drive specifications and characteristics, site preparation and layout, unpacking and installation information, plus hardware resources that include tool and test equipment requirements. It also provides a preventive maintenance schedule with procedures. Operational sequences and operation of the Operator Control Panel is also included. Complete removal and replacement procedures, and an Assembly/Sub-assembly locator are also provided.

## Illustrated Parts Breakdown - ER-0RP07-IP

This manual provides a cross reference listing of parts and part numbers with appropriate graphics. Major assemblies are shown in disassembly order. Appendix A will provide an ISS/DEC cross reference parts list for the parts listed on the Recommended Spares List.

## Microcode Listing - ER-0RP07-ML

This manual contains the functional and diagnostic listing of the microcode for every routine used by the 8080 and 2901 microprocessors in the RP07 drive.

## **1.5 MAINTENANCE PHILOSOPHY**

### **1.5.1 Objectives**

The objective of any maintenance program is to provide maximum equipment availability to the customer. The Preventive Maintenance (PM) program is designed to minimize the effect of known failures on the equipment and to enhance mean-time-between-failures (MTBF) and operating customer equipment availability.

### **1.5.2 Basic Considerations of Test and Inspection**

Two fundamental considerations in the preventive maintenance of electrical equipment are:

1. Visual Inspection
2. Electrical Test

Visual inspection is the Field Engineer's (FE) most valuable preventive maintenance tool. Most mechanical equipment failures will have given visual indications of their presence long before the actual failure occurs. It is, therefore, left to the awareness and perception of the FE to detect these failures before they occur.

Electrical test procedures, consisting of diagnostic programs and voltage measurements, are effective in locating potential and intermittent problems. Special emphasis should be placed on Safety (see Subsection 1.5.3 of this manual) when performing electrical test procedures.

Both visual and electrical considerations are contained within the PM schedule. See Chapter 5 of this manual, Preventive Maintenance.

#### **CAUTION**

DO NOT perform more than the recommended preventive maintenance. DO NOT disassemble equipment in an attempt to locate potential failure on a unit or assembly that is working properly. DO NOT perform extensive PM. DO NOT take measures other than visual inspection and electrical test check-out procedures.

#### **1.5.3 Safety**

Maintenance personnel should observe the following safety procedures and precautions to insure personal safety and operational equipment availability.

ALL WARNINGS, CAUTIONS, and NOTES contained within RP07 documentation should be read and exercised with the following understanding:

#### **WARNING**

Calls attention to a specific procedure that may result in personal injury if improperly performed.

#### **CAUTION**

Calls attention to a specific procedure that may result in damage to the equipment if improperly performed.

#### **NOTE**

Calls attention to and stresses the importance of associated text.



**1.5.3.1 AC Power** - Many of the preventive maintenance procedures require the removal of AC power from the drive. To insure safety, use the following procedure:

**WARNING**

AC power and cables must be removed from the drive to avoid personal injury or damage to the equipment whenever removing, replacing, or working on or near:

- AC Power Distribution Assembly (A6A2)
- Drive Motor/Brake Assembly (A3M1)
- Transformer Assembly (A6A10)
- Resonant Capacitor Assembly (A6A10C1)

See Cable Removal and Restoration, Subsection 1.5.3.2 of this manual.

**AC POWER REMOVAL**

To safely remove AC power from the drive and to minimize disruption to customer operations on other drives:

1. Obtain permission to disrupt customer operations. Place the ONLINE/OFFLINE switch to OFFLINE (down).
2. Place the START/STOP switch to STOP (down).
3. Open the drive front door. Remove the Electronics Library cover by loosening the two screws securing it and lifting the cover up and away from the drive.
4. Place the MASSBUS ENABLE/DISABLE switch, on the A12 Interface Control PCA to DISABLE (down).
5. Place the SERVICE switch to OFF (down).
6. At the back of the drive open the drive rear door. Set CB3, CB2 and CB1 OFF (down) in that order.

**AC POWER RESTORATION**

To restore AC power to the drive:

1. At the rear of the drive set CB1, CB2 and CB3 ON (up) in that order.
2. At the front of the drive set the SERVICE switch ON (up).
3. Set the MASSBUS ENABLE/DISABLE switch to ENABLE (up).

4. Place the START/STOP switch to START.
5. Place ONLINE/OFFLINE switch to ONLINE. Resume customer operations.

**1.5.3.2 Cable Removal and Restoration** - High current and potentials of up to 550 VAC may be present in the AC Power Distribution Assembly, Drive Motor Brake Assembly, Transformer Assembly, and Resonant Capacitor Assembly. To insure safety whenever working on or near these assemblies, use the following procedure for AC Power Cable Removal and Restoration:

**CAUTION**

DO NOT touch, remove, or work near the AC Power Distribution Assembly, Drive Motor/Brake Assembly, Transformer Assembly, or Resonant Capacitor Assembly until the AC power has been disconnected from the drive. Personal injury may result.

**CABLE REMOVAL:**

**WARNING**

To prevent personal injury, always disconnect main source of AC power BEFORE removing AC power cables from the drive.

To safely remove cables from the drive: Obtain permission to disrupt customer operations, then place the drive OFFLINE. Place the START/STOP switch (on the Operator Control Panel) to STOP. Set CB1 OFF (down). Disconnect AC/IN (A2J1) and AC/OUT (A2J2) connectors from the AC Power Distribution Assembly (A2).

**RECONNECT CABLES:**

Reconnect AC cables in the following sequence: Reconnect AC/IN (A2J1) and AC/OUT (A2J2) connectors to the AC Power Distribution Assembly (A2). Set CB1 ON (up). Place the START/STOP switch (on the Operator Control Panel) to START. Place drive ONLINE. Resume customer operations.

### 1.5.3.3 Printed Circuit Assemblies

#### **WARNING**

DO NOT touch high current components (wirewound resistors, power transistors, capacitors, and diodes) on the PCAs until the components have cooled to a safe temperature and have had time to discharge current loads. Personal injury may result.

#### **CAUTION**

To prevent possible serious damage to drive internal circuitry, CB1, CB2 and CB3 must be OFF (down) when removing PCAs A1A1, A1A2 and/or A1A3.

Whenever PCAs A1A1, A1A2 and/or A1A3 are to be removed from the drive, the START/STOP switch (on the Operator Control Panel) must be in the STOP position. CB1, CB2, and CB3 must be OFF.

Whenever PCAs A1A4 through A1A17 are to be removed from the drive, the Service switch (A1A3) must be OFF (down).

Certain PCAs contain Static Sensitive Devices which are susceptible to electrostatic discharge damage (ESD). See Subsection 1.5.3.4 for safety procedures and precautions of static sensitive PCAs.

### 1.5.3.4 Static Sensitive PCAs

#### **CAUTION**

DO NOT touch components on PCAs. They may be HOT. Personal injury may result. Allow sufficient time for components to cool to a safe temperature and/or discharge these loads.

Electrostatic charge generation cannot be completely eliminated, therefore it must be controlled to prevent electrostatic discharge damage (ESD) to Static Sensitive Devices. (Static Sensitive Devices are characterized as planar and MOS devices which are susceptible to current leakage and the breakdown of voltage under certain conditions.)

Electrostatic discharge is a threat to device reliability and can exist without the realization of the user. PCAs contain Static Sensitive Devices are susceptible to ESD.

PCAs A4, A7, A8, and A14 through A17 contain devices which are susceptible to electrostatic discharge damage (ESD) when improperly handled. "Specific precautions" must be exercised to avoid failure from ESD when handling Static Sensitive PCAs.

ESD can be controlled, eliminating device failure and damaging stress to Static Sensitive Devices.

**NOTE**

Personnel who will handle PCAs containing Static Sensitive Devices should be aware of the potential for component and/or device failure and damage by static.

**1.5.3.5 Controlling Static Damage in the Field**

When working on the RP07 the CE should be aware of the potential for machine performance degradation or damage due to static discharge. The hazard is greatest when the CE is working on or near the electronics libraries. For this reason, the CE must observe the following rules and guidelines.

1. **The CE must wear a wrist strap.** The wrist strap serves as a leakage path from the human body to ground, bleeding off any static charge build-up. The wrist strap must be adjustable and conductive, making contact with the sweat layer around the wrist. The band is connected via a quick-release connector to the grounding strap containing a 500K to 1 megohm resistance. The resistor serves to minimize direct human grounding which could result in a shock hazard. The wrist strap itself must never be grounded directly, only through the resistance.
2. **All electronic components and assemblies are to be treated as Electrostatic Discharge Sensitive (ESDS).** They are to be shielded with appropriate static-protection material whenever they are not installed in the machine.
3. **The inner liner and compartments of all servicing "caddies" are to be constructed of non-corrosive volume conductive foam to protect static-sensitive components.**
4. **All storage cabinets, trays and parts bins used to house ESDS components are to be grounded.**
5. **All static generating materials, such as plain plastics, synthetic fabrics and aerosols are to be kept out of protected work areas.**
6. **Plastic outer wrappings and dunnage of all received goods are to be removed outside of the protected work areas and are not to be brought into protected work areas.**

### 1.5.3.6 Head Disk Assembly

#### **CAUTION**

DO NOT move the drive over rough surfaces or long distance without using the shipping rod. Severe damage to the HDA, heads or stack may result.

Before relocating an RP07 drive, the shipping rod must be used. The shipping rod is clipped onto the front face of the drive baseplate casting. Chapter 2 of this manual (Unpackaging and Offline Checkout) provides detailed instructions for drive relocation.

## CHAPTER 2

### UNPACKAGING AND OFFLINE CHECKOUT

#### **WARNING**

HAZARDOUS VOLTAGES ARE PRESENT INSIDE THIS EQUIPMENT. INSTALLATION AND SERVICING SHOULD BE PERFORMED BY A QUALIFIED AND TRAINED SERVICE REPRESENTATIVE. BODILY INJURY OR EQUIPMENT DAMAGE MAY RESULT FROM IMPROPER SERVICING. REFER TO THE SERVICE MANUAL FOR PROPER INSTRUCTIONS.

#### **2.1 INTRODUCTION**

This chapter provides unpackaging and offline checkout procedures for the RP07 including:

- Site Preparation and Requirements
- Shipping/Receiving and Unpacking
- Inspecting
- Cabling
- Powering Up
- Subsystem Check
- Moving

#### **2.2 SITE PREPARATION**

This section presents site requirements to insure optimum performance of the RP07 Disk Drive.

- Space Requirements
- Power Requirements
- Environmental Considerations

##### **2.2.1 Space Requirements**

Figures 2-2-1-A and 2-2-1-B illustrate RP07 space requirements.

### CAUTION

Do not position RP07 blower intake above a subfloor air conditioning outlet or damage to equipment may result.

The RP07 weighs approximately 181.44 kg (400 lbs.) total; side covers, 11.25 kg (25 lbs.).

Floor loading is 381 kg/m<sup>2</sup> (78 lbs. per square foot).

#### 2.2.2 Power Requirements

The RP07 uses three-phase AC input power and can be configured for either 60 Hz or 50 Hz operation. (See Subsection 2.6, Power Verification, and/or Subsection 2.7 for Power/Frequency Conversion.)

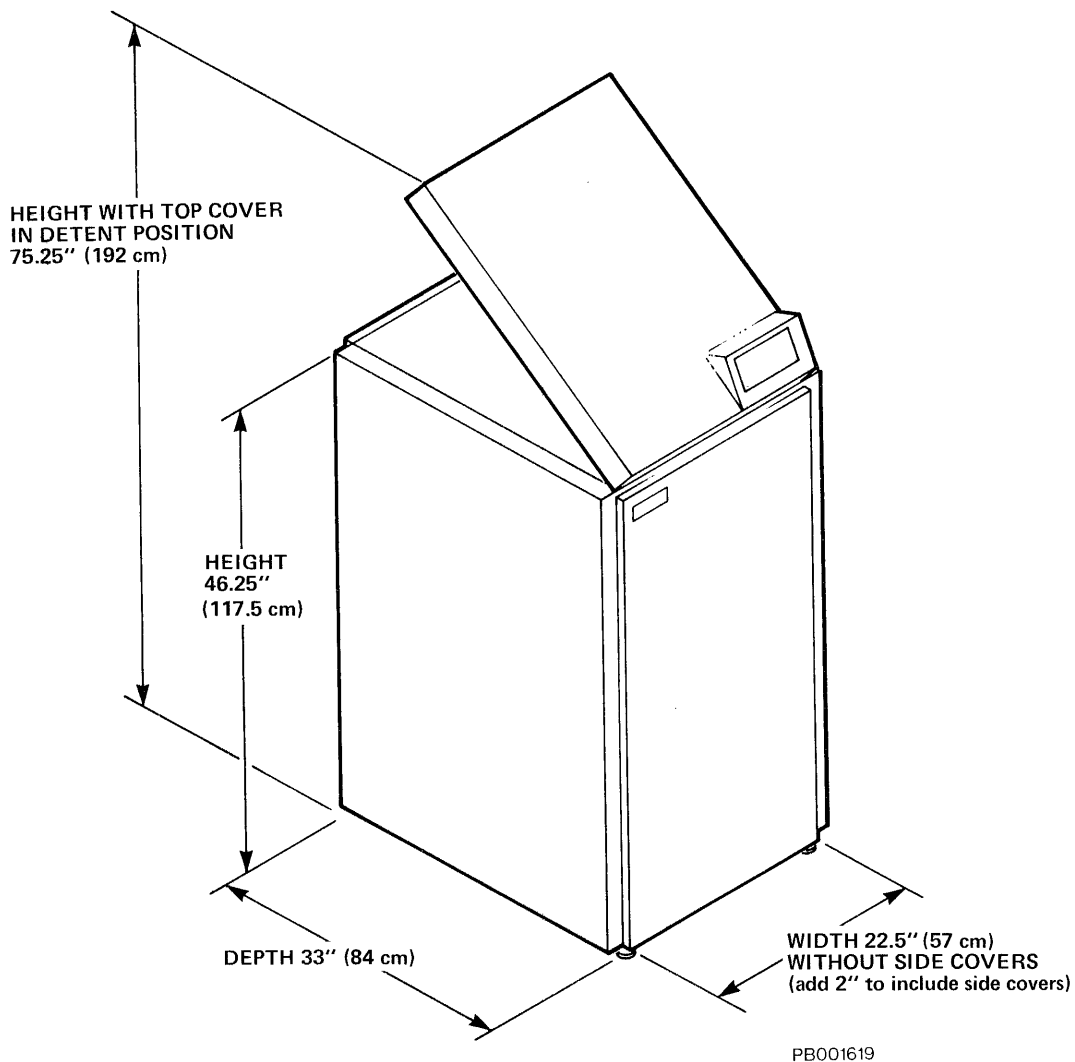

Figure 2-2-1-A RP07 Dimensions

**NOTE**

1. Up to three (3) drives may be strung together using the three-phase AC power source with one AC power cable. See Subsection 2.8 for Cable Connection.
2. Power Verification (Subsection 2.6) must be completed before cable connection.

**WARNING**

This machine is not UL approved when configured to the following specifications

- 50 Hz Wye - 380/400 volts
- 50 Hz Wye - 400/410 volts
- 50 Hz Delta - 200/208 volts
- 50 Hz Delta - 220 volts
- 50 Hz Delta - 240 volts

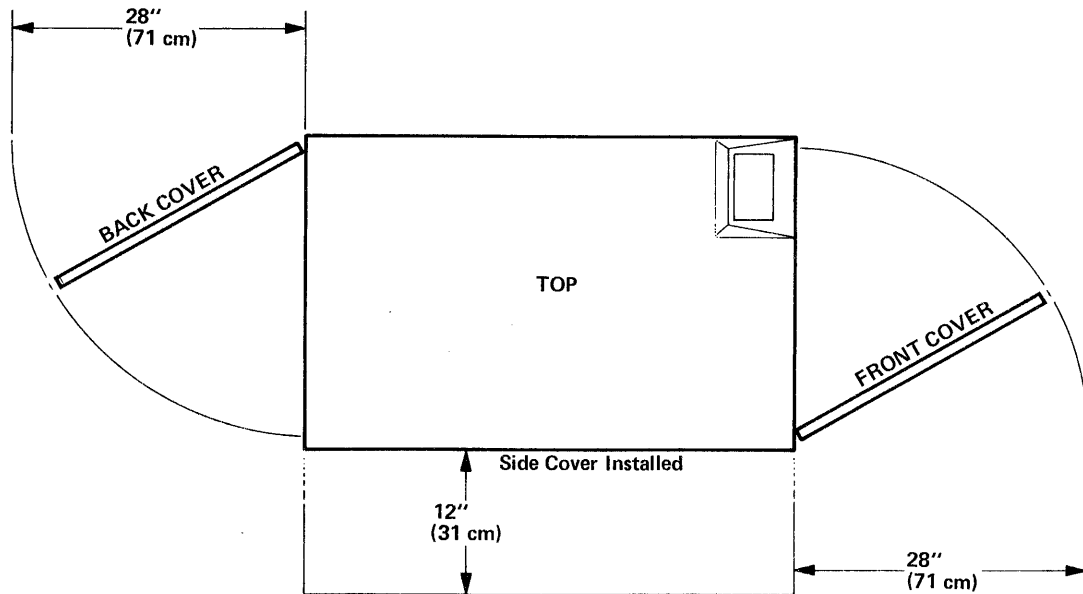

Figure 2-2-1-B RP07 Service Clearances



The following table lists AC power requirements:

<u>TYPE 3 Voltage Taps</u>	<u>FREQUENCY TOLERANCE</u>	<u>NOMINAL OR TAP VOLTAGE</u>	<u>TERMINAL TAP (TBI)</u>	<u>VOLTAGE RANGE</u>
60 Hz	+2%	200/208	2	170-220
60 Hz	+2%	220	3	184-236
60 Hz	+2%	240	4	201-256
50 Hz	+2%	200/208	2	170-220
50 Hz	+2%	220	3	184-236
50 Hz	+2%	240	4	201-256

<u>TYPE 3 Voltage Taps</u>	<u>FREQUENCY TOLERANCE</u>	<u>NOMINAL OR TAP VOLTAGE</u>	<u>TERMINAL TAP (TBI)</u>	<u>VOLTAGE RANGE</u>
60 Hz	+2%	200/208	2	170-220
60 Hz	+2%	220	3	195-253

\*TBI has an additional terminal tap ground wire.

The RP07 is designed to operate with the following alternative input requirements:

<u>VOLTAGE</u>	<u>PHASE</u>	<u>HZ POWER</u>
1. 200/240	3	60
2. 230/240	3 Delta	50
3. 380/410	3 Wye	50

RP07 Surge Current is 40 amps at 240 VAC. Surge current shall not exceed 55 amps.

RP07 Operating Current is 7 amps at 240 VAC. Operating current shall not exceed 8 amps.

KVA is 1.4 @208 (Typ) 1.9 @230 + 10%, max.

Drives are shipped wired for the input requirements specified at the time of order.

The label affixed to the frame, above the Absolute Filter, identifies drive power connection configuration.

### 2.2.3 Environmental Considerations

Environmental specifications for the RP07 in operating and non-operating (storage or shipping) environments are found in Subsections 2.2.3.1 and 2.2.3.2.

**2.2.3.1 Operating Environment** - When the RP07 has been exposed to conditions of temperature or humidity other than those specified for operation, the device must have twelve (12) hours on site to stabilize at the specified gradient before being unpackaged.

The RP07 operates in an environment meeting the following conditions:

Operating Temperature Range:	15 <sup>o</sup> C (59 <sup>o</sup> ) to 32 <sup>o</sup> C (90 <sup>o</sup> F) with max. change of 6.6 <sup>o</sup> C (12 <sup>o</sup> F) per hour.	
Operating Humidity Range:	20%-80% with max. wet bulb of 25 <sup>o</sup> C (77 <sup>o</sup> F)	
Altitude:	Sea level to 2400 M (sea level to 8000 feet)	
Shock:	1g maximum 10 - 20 milliseconds on each of the mutually perpendicular axes	
Vibration Levels:	<u>Frequency</u>	<u>Amplitude</u>
	5-25 Hz	0.0014 inches DA
	25-95 Hz	0.0007 inches DA
	95-300 Hz	0.3 g
Attitude:	To within 15 <sup>o</sup> vertical alignment	
Heat Dissipation:	Not exceeding 7,000 BTU per hour (2.052 KW)	
Noise Level:	Less than 55 NCL (Noise Criteria Level)	

**CAUTION**

When an RP07 has been exposed to a non-operating environment, an installation inspection must be performed before an operational check or damage to equipment may result.

**2.2.3.2 Non-Operating Environment** - The RP07 may be STORED and/or SHIPPED under the following environmental conditions:

Shipping Temperature: (in shipping container)	-40 <sup>o</sup> C (-40 <sup>o</sup> F) to +66 <sup>o</sup> C (+151 <sup>o</sup> F)
Gradient (rate of change)	14 <sup>o</sup> F/hour

Storage Temperature: (in shipping container)	-40°C (-40°F) to +66°C (+151°F)	
Gradient: (rate of change)	14°F/hour	
Non-Operating Humidity		
a. Drive on Site: Wet Bulb Temperature:	8% - 85% R.H with no condensation 24.75°C (77°F), maximum	
b. Drive in Container:	5% - 90% R.H. with no condensation	
Altitude:	304.8m (1,000 feet) below sea level to 3,048m (10,000 feet) above sea level	
Shock:	15g 10 - 20 milliseconds on each perpen- dicular axis	
Vibration Levels:	<u>Frequency</u>	<u>Amplitude</u>
	5-25 Hz	0.008 inches DA
	25-95 Hz	0.004 inches DA
	95-300 Hz	2g to 5g

### 2.3 SHIPPING AND RECEIVING

This section includes a description of RP07 standard PACKAGING and the procedures for UNPACKING and INSPECTING the drive.

#### CAUTION

RP07 weighs approximately 400 pounds and is sensitive to shock and vibration. Special unloading equipment and safe working procedures must be used or damage to equipment may result.

#### 2.3.1 Shipping Package

The RP07 is crated as for air shipment. The PACKAGE described below is specified standard (domestic air):

The drive is shipped:

1. With side covers installed.
2. Covered by a poly bag.
3. Bolted to a pallet.
4. Encased in a cardboard carton.

5. With a Carriage Shipping Rod to maintain the HDA (Head Disk Assembly) in fixed position during shipment.

**RETAIN:**

1. Packing list envelope
2. Receipts
3. All packing parts and materials

**2.3.2 Unpacking**

This subsection provides instructions for unpacking RP07. The drive should be stored on site at room temperature for 12 hours before proceeding with this procedure.

**WARNING**

Do NOT hold any portion of the top or side covers when moving or lifting the drive. Personal injury or damage to the equipment may result. Always hold drive by the frame structure.

**NOTE**

Verify factory sealed contents match packing list.

The RP07 is shipped in a specially designed protective package. The drive is bolted to a pallet and covered with a carton which is then strapped to the pallet. See Figure 2-3-2-A.

To unpack the drive:

1. Unstrap carton and open top flaps.
2. Remove the wooden ramp.
3. Remove the 4 top foam pads.
4. Lift carton off drive.
5. Remove poly bag.

**NOTE**

When performing the following steps, do NOT scratch the drive exterior surface.



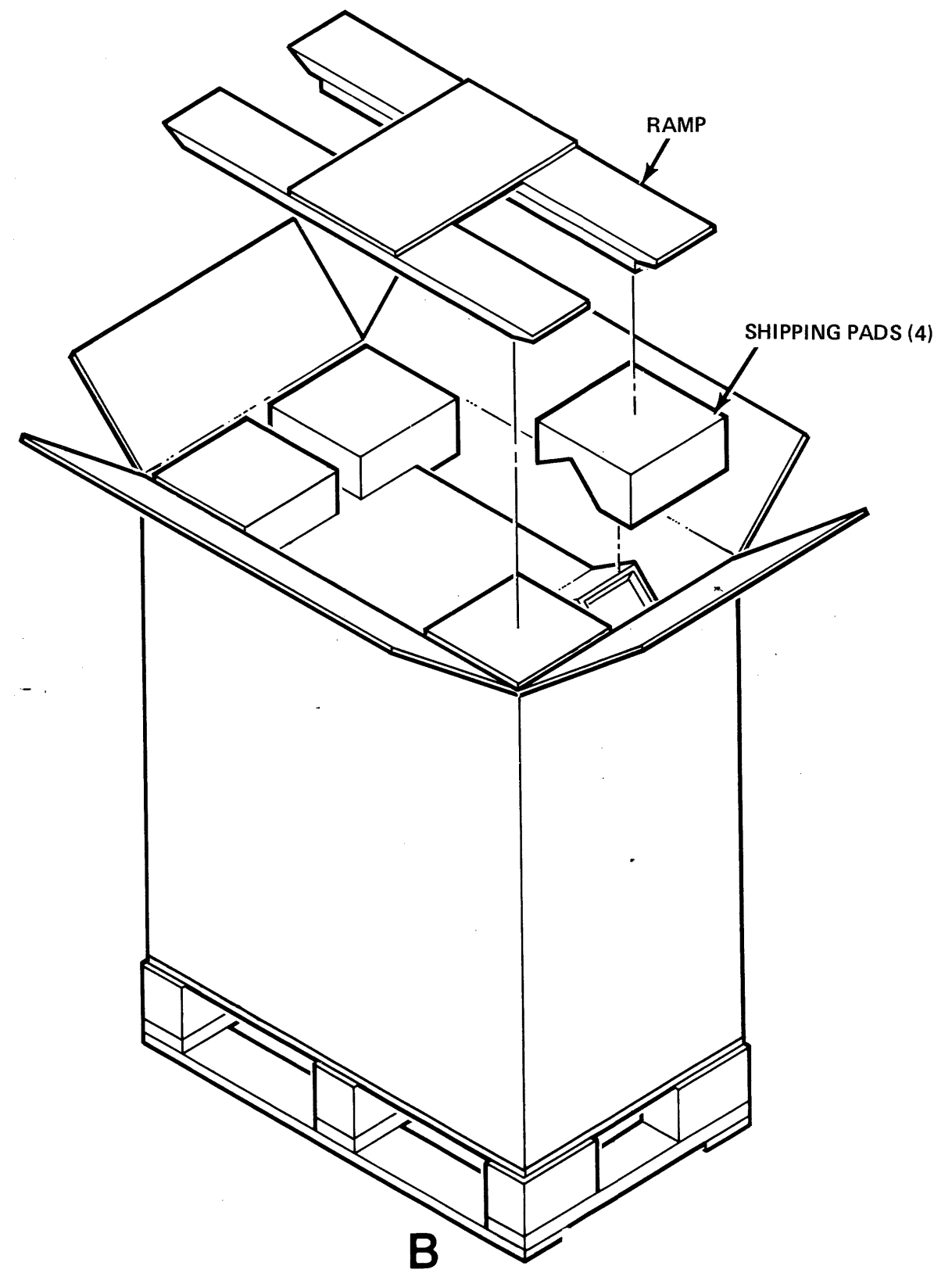
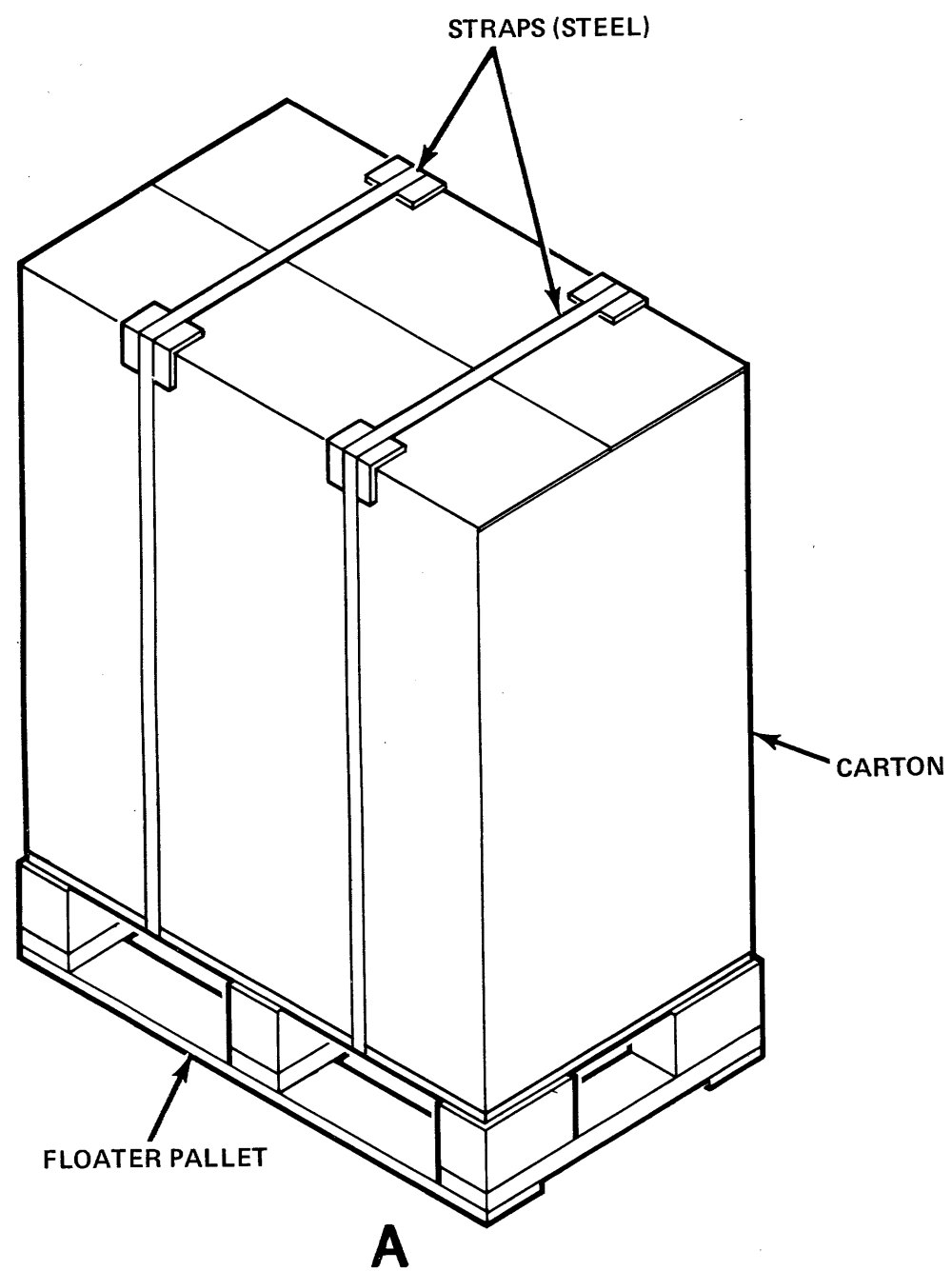

Figure 2-3-2-A RP07 Shipping Package

6. Open the top cover and remove drive side covers (to allow access to bolts holding drive to pallet) as follows:
  - a. Remove two screws and lockwashers that attach side covers to drive frame.
  - b. Lift side covers up and off drive.
7. Remove the four 1/2" bolts that hold drive frame to pallet. See Figure 2-3-2-B.

**NOTE**

Bolts are located under pallet opening on each side of drive frame.

8. Place wooden ramp into slot in pallet; insure guides are to the inside.

**WARNING**

RP07 weighs approximately 400 pounds. To avoid personal injury, request assistance when rolling drive off pallet.

9. Guiding the drive along the ramps, roll drive down off the ramp onto the floor.

### 2.3.3 Inspecting

This subsection provides information for inspection of RP07. (See Figure 2-3-3-A.)

**NOTE**

1. All original packing materials and receipts must be retained to support any claim of shipping damage.
  2. All claims should be filed promptly with the transportation company involved. Notify supplier's representative of any claim.
1. Visually inspect drive exterior for shipping damage.





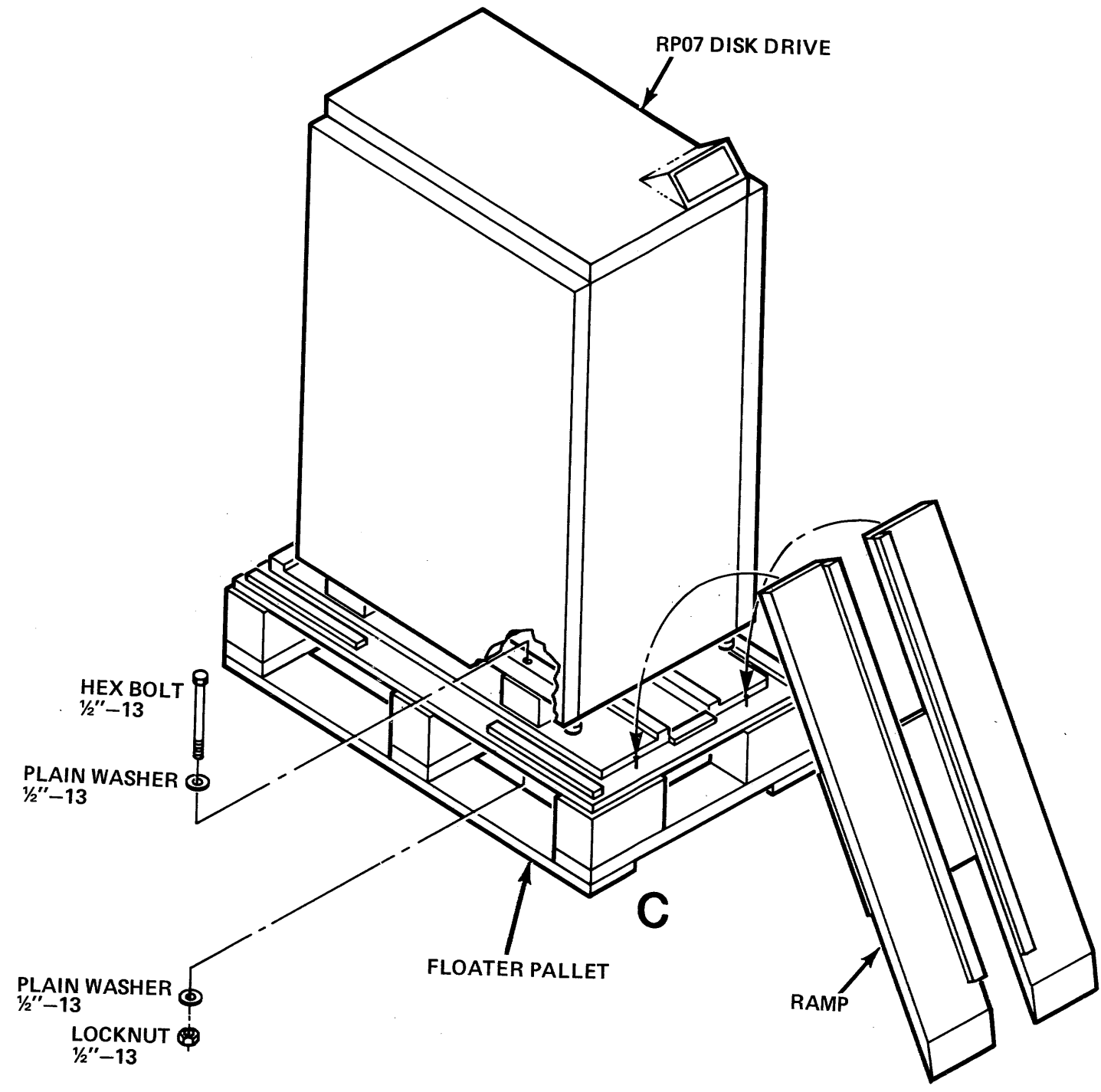

PB001744  
12/82

Figure 2-3-2-B Unloading the Drive from the Pallet

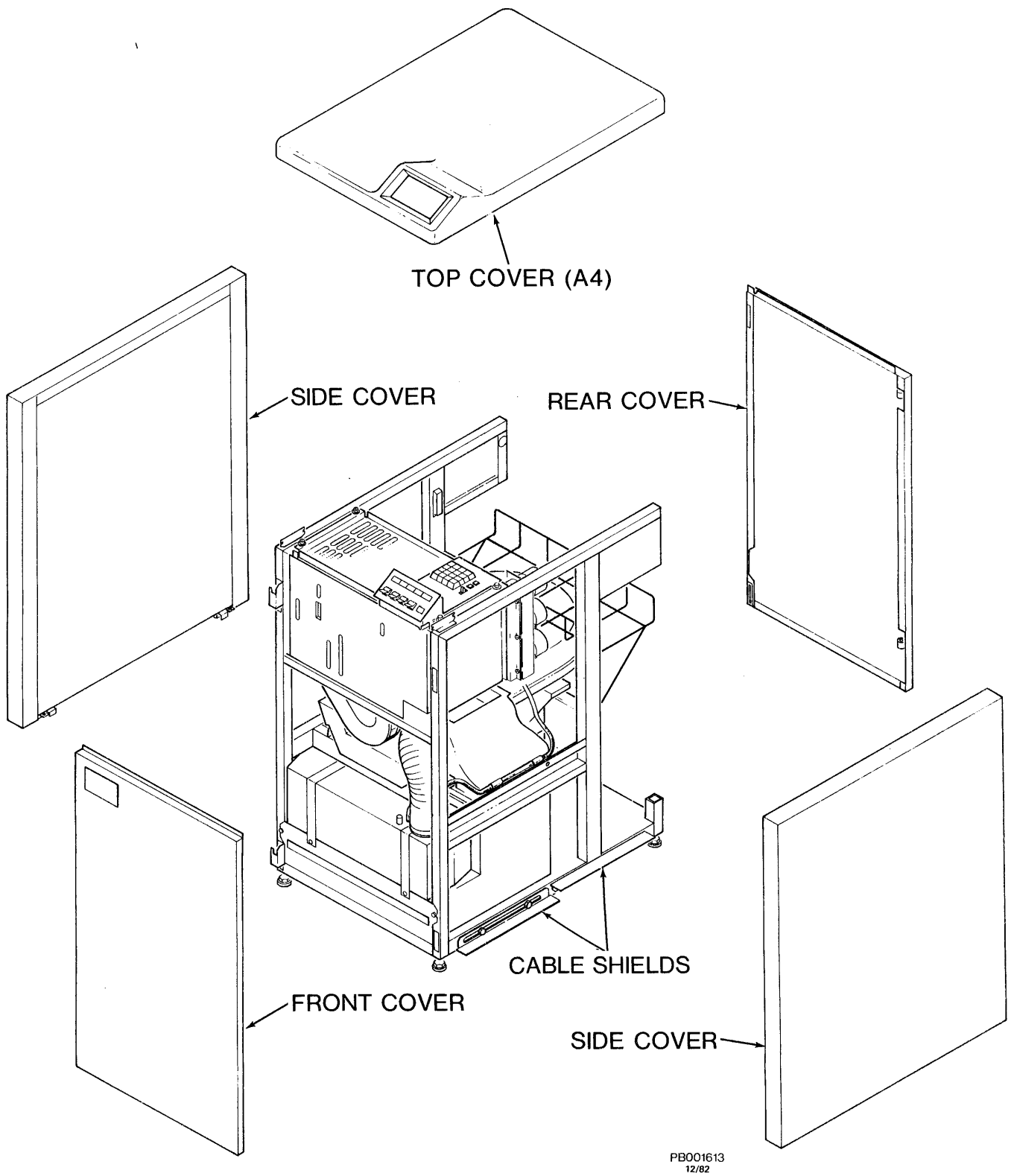
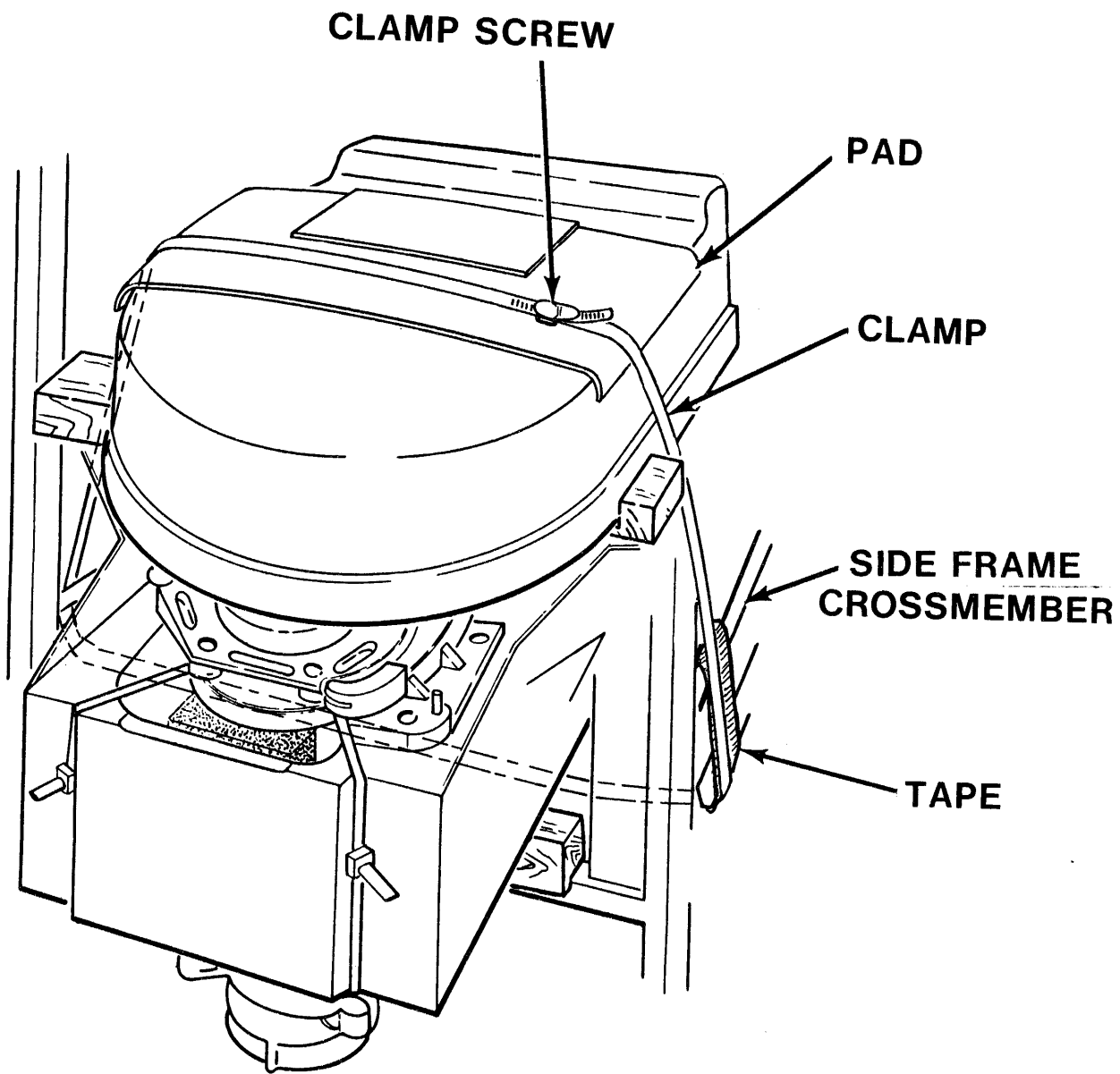

Figure 2-3-3-A RP07 with Service Covers Removed

2. Remove remaining service covers.
  - a. Top Cover
    1. Open top cover and raise to detent position. (Cover supported by its U-shaped support rod.)
    2. Supporting the weight of top cover, press inward on U-shaped rod and remove both ends of the rod (one at a time) from holes in the drive frame.
    3. Raise rod ends (one at a time) towards the upper (open) edge of the cover; clip them into the corner clips.
    4. Holding the cover open, remove bar hinge from one side of the base of the cover (pressing outward until it is released). Repeat this procedure to release the other hinge.
    5. Remove top cover from drive.
  - b. Front Cover
    1. Open the front cover by placing one hand under the edge of the top cover, at the right hand corner, and pull outward.
    2. Lift cover upward to disengage it from the two hinges on the left hand side of drive frame.
  - c. Rear Cover
    1. Open the top cover assembly and pull rear cover outward, to a 60 degree angle, from the drive.
    2. Lift the cover upward to disengage it from the two hinges on the left hand side of frame.
3. Remove the clamp and padding from top of HDA and out from under the baseplate. See Figure 2-3-3-B.
4. Remove the 2 wooden blocks from between the baseplate and the frame by sliding them forward.
5. Remove and retain belt guard from baseplate assembly. Remove the drive motor block and the tie wrap running over the baseplate. See Figure 2-3-3-B. Reinstall belt guard to baseplate assembly.
6. The EMA cover shield, taped to the side of the drive frame for shipment, should be removed. See Figure 2-3-3-C. Do not install it at this time.



PB001933-1

Figure 2-3-3-B HDA Clamp and Padding

7. At the front of the drive remove the front baseplate block (wood) from between the baseplate and the frame crossmember. See Figure 2-3-3-D. Note the finger hole in the underside of the block for ease of removal. Retain for future use.
8. At the rear of the drive remove the rear baseplate block (wood) from between the baseplate and the frame crossmember. Lift up on the end of the baseplate for ease of removal. See Figure 2-3-3-E. Retain for future use.
9. On both sides of the drive remove the cable shields and save. See Figure 2-3-3-F.
10. Visually check drive for bent backpanel pins or loose hardware.

## **2.4 CABLE CONFIGURATION OVERVIEW**

RP07 cable configuration overview is described in this section:

- Power Cables
- Ground Cables
- Sequencing Cables
- Massbus Cables

The cable connection procedures are described in Subsection 2.8. System cabling should not be performed until after OFFLINE Checkout has been performed.

### **2.4.1 Power Cable Configuration**

This subsection discusses the AC power cable, ground cable, and sequencing cable provided with RP07.

#### **2.4.1.1 AC Power**

1. Individual

Main AC power is usually individually connected, each drive plugged into a source power outlet at the wall.

An AC power cable is provided with each drive.

2. Daisy Chain

AC power can be daisy chained, maximum three drives. Drives must be BOLTED together. The first drive in the chain is plugged into source power outlet at the wall.

A suitable cable is available if drives are to be daisy chained.

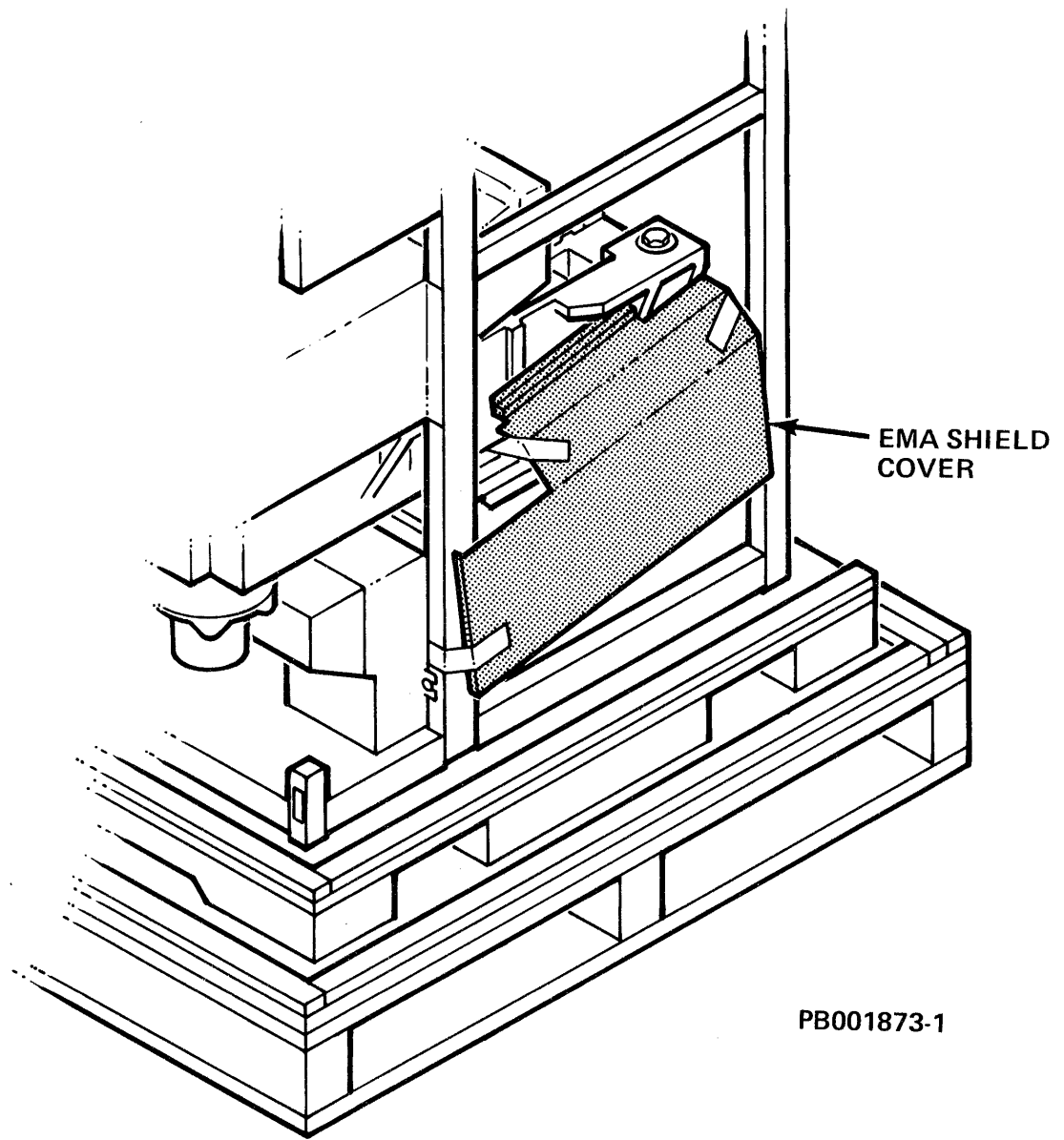

Figure 2-3-3-C EMA Cover Shield Storage During Shipping

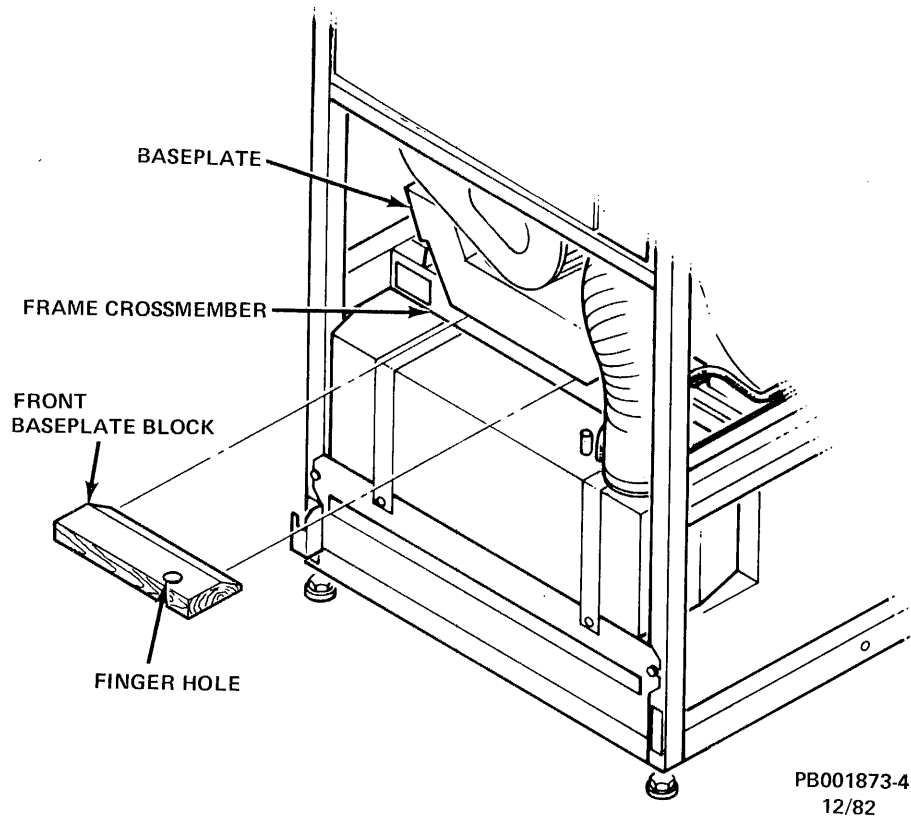

Figure 2-3-3-D Front Baseplate Block

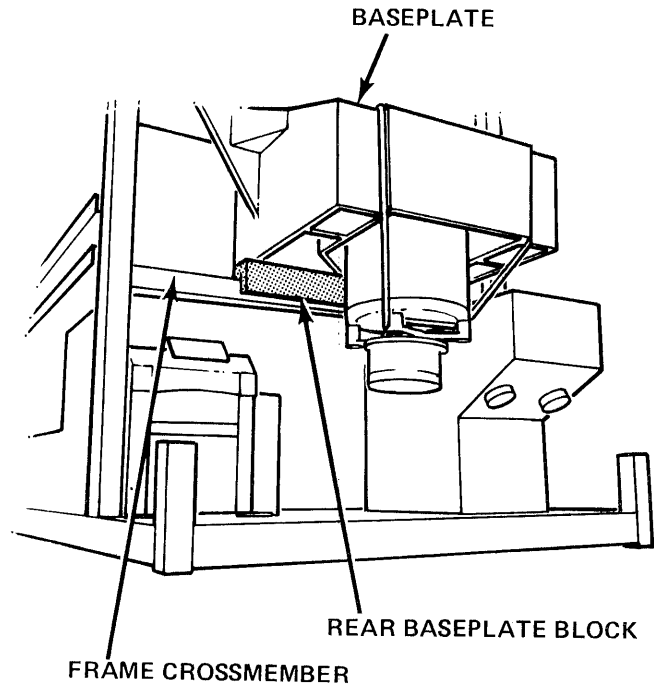

Figure 2-3-3-E Rear Baseplate Block

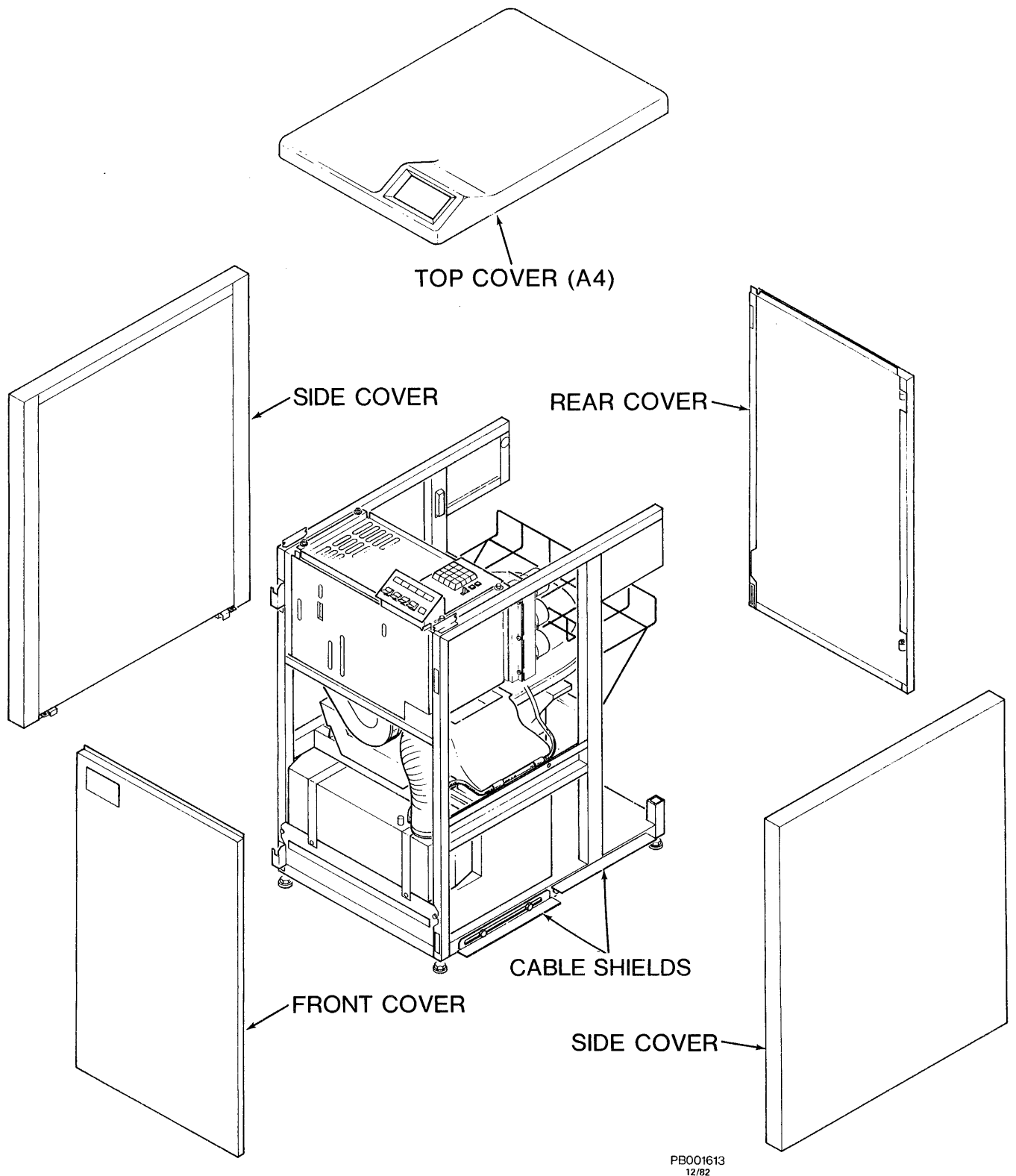

Figure 2-3-3-F Cable Shields



### 2.4.1.2 Ground

1. AC Ground

A ground strap is provided as part of the AC power cable for individually connected drives or first drive in a string.

2. DC Ground

DC ground is connected from the RH controller to the first drive and then daisy chained from drive to drive.

A DC ground cable is provided with each drive.

**2.4.1.3 Power Sequencing** - The power sequencing system minimizes the effects of starting current surges: drives power up one at a time in sequence during initial power up and restart.

A Power Sequence cable and Sequence Cable Terminator are provided with each drive.

### 2.4.2 Massbus Cable Configuration

The Massbus combines the wires for read/write data, control signals, and timing and is the transmission medium connecting RP07 with the RHXX controller.

The following Massbus configurations may be selected as required:

1. Single Port - One Massbus originating at one RHXX controller is daisy chained through several RP07 drives, eight maximum. See Figure 2-4-2-A.
2. Dual Port/Dual RHXXs/Single System/Single Cabinet - See Figure 2-4-2-B.
3. Dual Port/Dual RHXXs/Dual System/Adjacent Cabinets - See Figure 2-4-2-C.
4. Dual Port/Dual RHXXs/Dual System/Dual Cabinets - See Figure 2-4-2-D.

#### External Massbus Cable

The provided standard external Massbus Cable (60 twisted-pair, round bundle with a characteristic impedance of 130 ohms) can be used to daisy chain additional RP07 drives installed adjacent to each other. The maximum Massbus cable length allowed is 160 feet from controller to the last drive in a string.

#### Internal Massbus Cable

The flat 40-wire conductor cables internal to the drive are factory connected from the back of the cabletray to the backpanel.

#### Ground

Ground continuity is maintained throughout cable system. Internal and external drain wires are connected to each other and to logic ground.

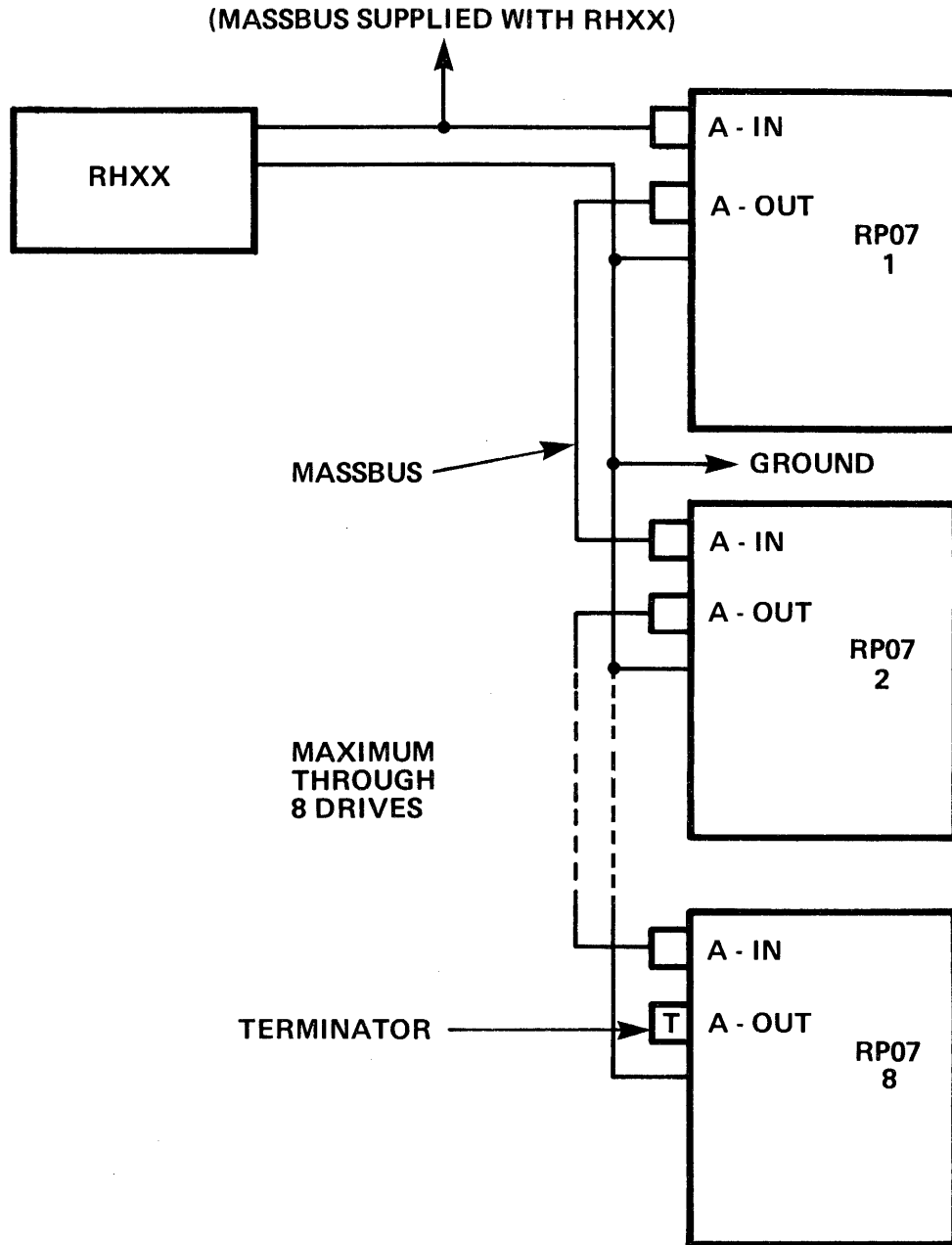

**NOTE:**

- (1) GROUND CABLE AND MASSBUS SHOULD FOLLOW THE SAME PATH AND MUST BE TIE-WRAPPED TOGETHER.

PB001871-1

Figure 2-4-2-A Single Port (MASSBUS)

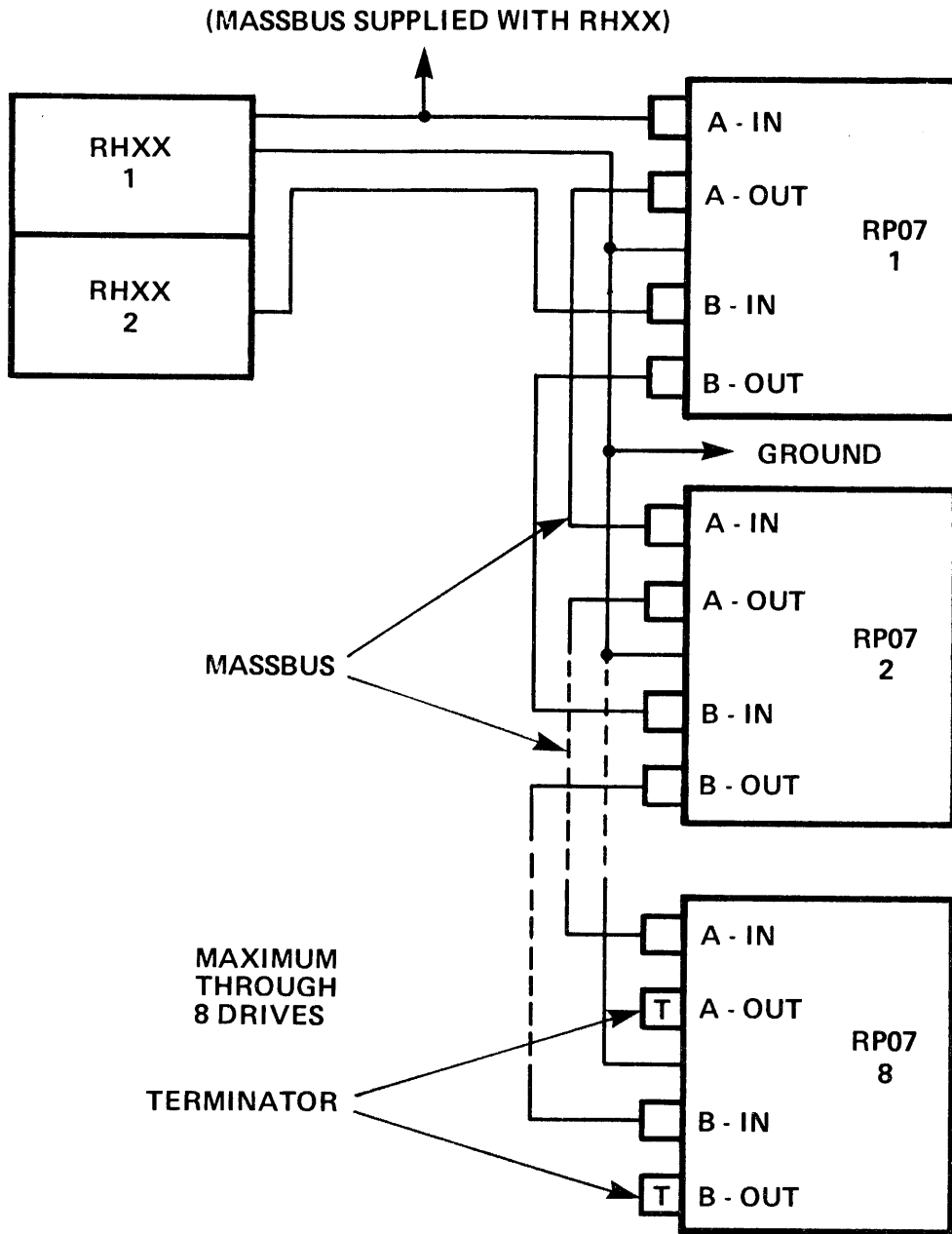

**NOTES:**

- (1) GROUND CABLE AND MASSBUS SHOULD FOLLOW THE SAME PATH AND MUST BE TIE-WRAPPED TOGETHER.
- (2) RHXX'S ARE GROUNDED TOGETHER.

PB001871-2

Figure 2-4-2-B Dual Port/Dual RHXXs/Single System/Single Cabinet (MASSBUS)

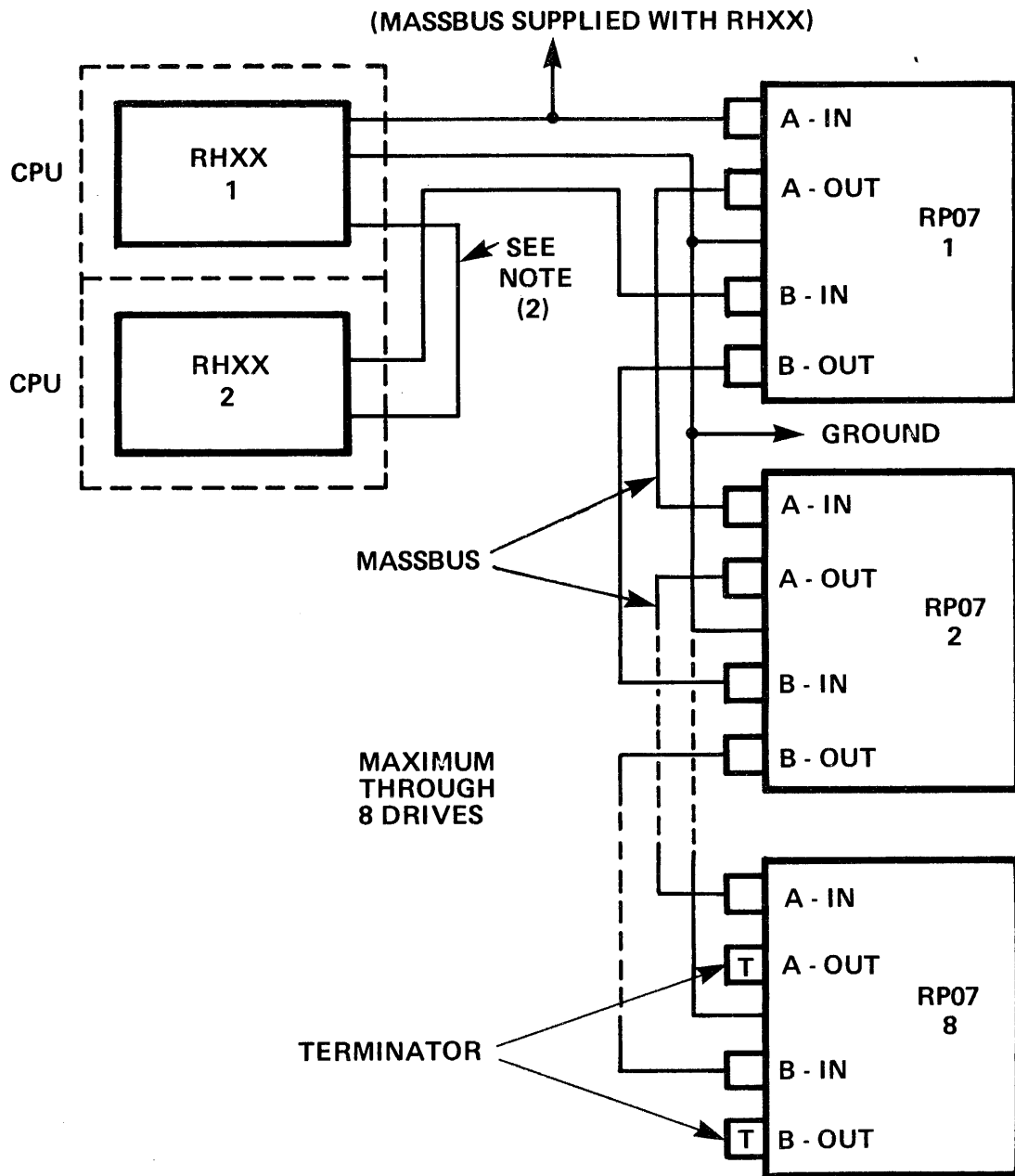

**NOTES:**

- (1) GROUND CABLE AND MASSBUS SHOULD FOLLOW THE SAME PATH AND MUST BE TIE-WRAPPED TOGETHER.
- (2) ADDITION OF A GROUND JUMPER FROM CABINET TO CABINET IS RECOMMENDED.

PB001871-3

Figure 2-4-2-C Dual Port/Dual RHXXs/Dual System/Adjacent Cabinets (MASSBUS)

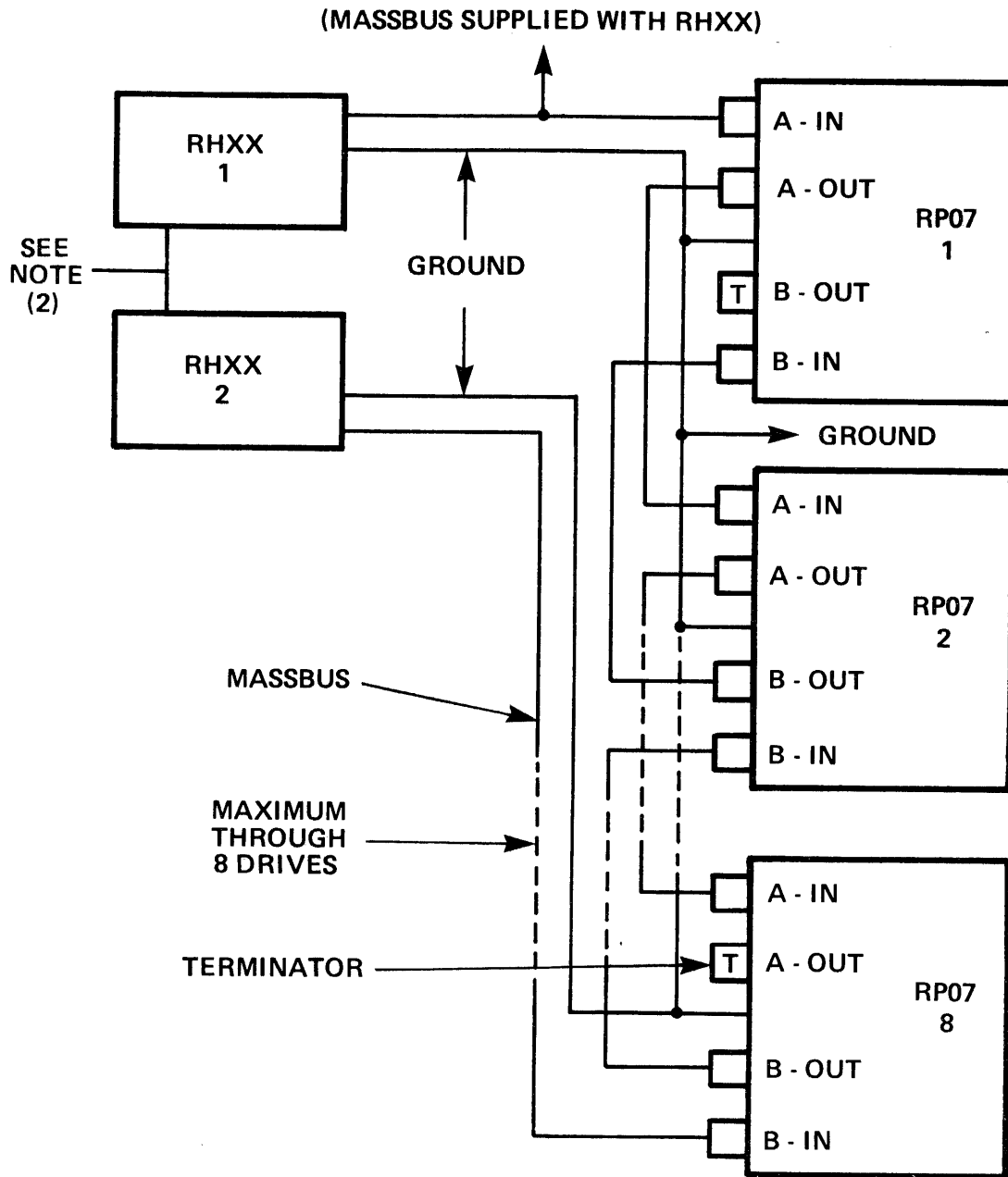

**NOTES:**

- (1) GROUND CABLE AND MASSBUS SHOULD FOLLOW THE SAME PATH AND MUST BE TIE-WRAPPED TOGETHER.
- (2) NO GROUND CONNECTION TO ELIMINATE GROUND LOOPS.

PB001871-4

Figure 2-4-2-D Dual Port/Dual RHXXs/Dual System/Dual Cabinets (MASSBUS)

## 2.5 POSITIONING AND ADDRESSING THE DRIVE

All drives in the system must be correctly positioned and addressed. The address locates a drive for the controller.

### 2.5.1 Positioning the Drive

Perform the following steps to position each drive:

1. Roll drive into its assigned position in subsystem.
2. Level each drive by lowering the four leveler jacks enough to remove all weight from casters. Adjust the jacks so that bolt holes in side frames line up exactly.

Verify that the drive is level by placing a level on the horizontal cross bar under the Electronics Library and on the top side frame bar.

3. See Figure 2-5-1. Bolt frames to each other, using the two frame bolts provided. Install bolts through holes at upper front and lower rear of drive. Install lockwashers under bolt heads and nuts, flat washers between frames, as shown.

### 2.5.2 Addressing and Jumpering

The serial number of each drive will be factory jumpered or hardwired on the A1J26 backpanel connector. The number is stored in the RPSN drive register so that the controller may read it. For serial number jumper configuration table, see Figures 2-5-2-1-C and 2-5-2-1-D.

**2.5.2.1 Single Port Addressing** - Drive Address for single port drives is located on A1A13 PCA (A Port). This PCA must be jumpered with the correct drive address. (See Figure 2-5-2-1-A.)

The drive may be addressed 0 - 7, binary value. See Figure 2-5-2-1-B for illustrated Drive Address Configurations, 0 - 7.

**2.5.2.2 Dual Port Addressing** - Drive Address locations for dual port drives are on A1A13 PCA (A Port) and A1A11 PCA (B Port).

Both PCAs must be jumpered with the drive address in the same manner as single port. See Figure 2-5-2-1-B to jumper drive(s).

**2.5.2.3 Drive Characteristics** - Installation of terminal connecting links between specific odd and even numbered pins of the A1J26 backpanel connector is performed to indicate the presence of certain installed options in the drive and to establish selection of certain operating characteristics of the RP07 Disk Drive. See Table 2-5-2-3.

Table 2-5-2-3 Drive Option Jumpers

A1J26 PINS	LINK PRESENT	LINK ABSENT
1 - 2	Dual Port Option Installed	Single Port Drive
5 - 6	Non-Interleaved Sectors	Interleaved Sectors
7 - 8	Mode 2 Operation	Mode 1 Operation

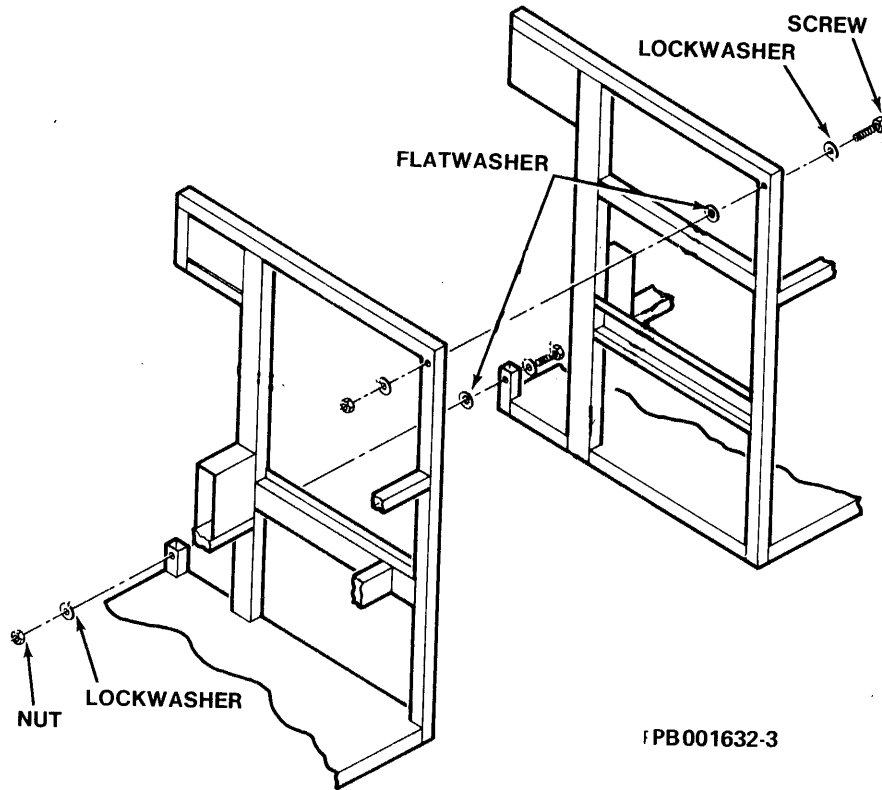
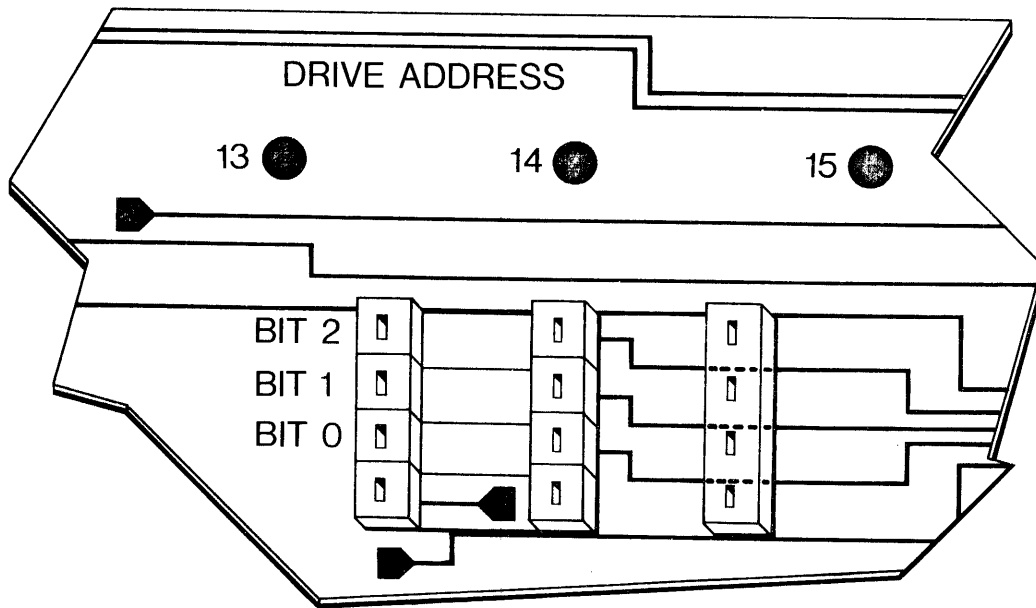

Figure 2-5-1 Bolting the Drives Together



**NOTE**

New A1A11 PCAs have rotary switches for drive addressing, instead of jumpers.

PB001625-1

Figure 2-5-2-1-A Drive Address Jumpers on the A1A11/A1A13 PCA

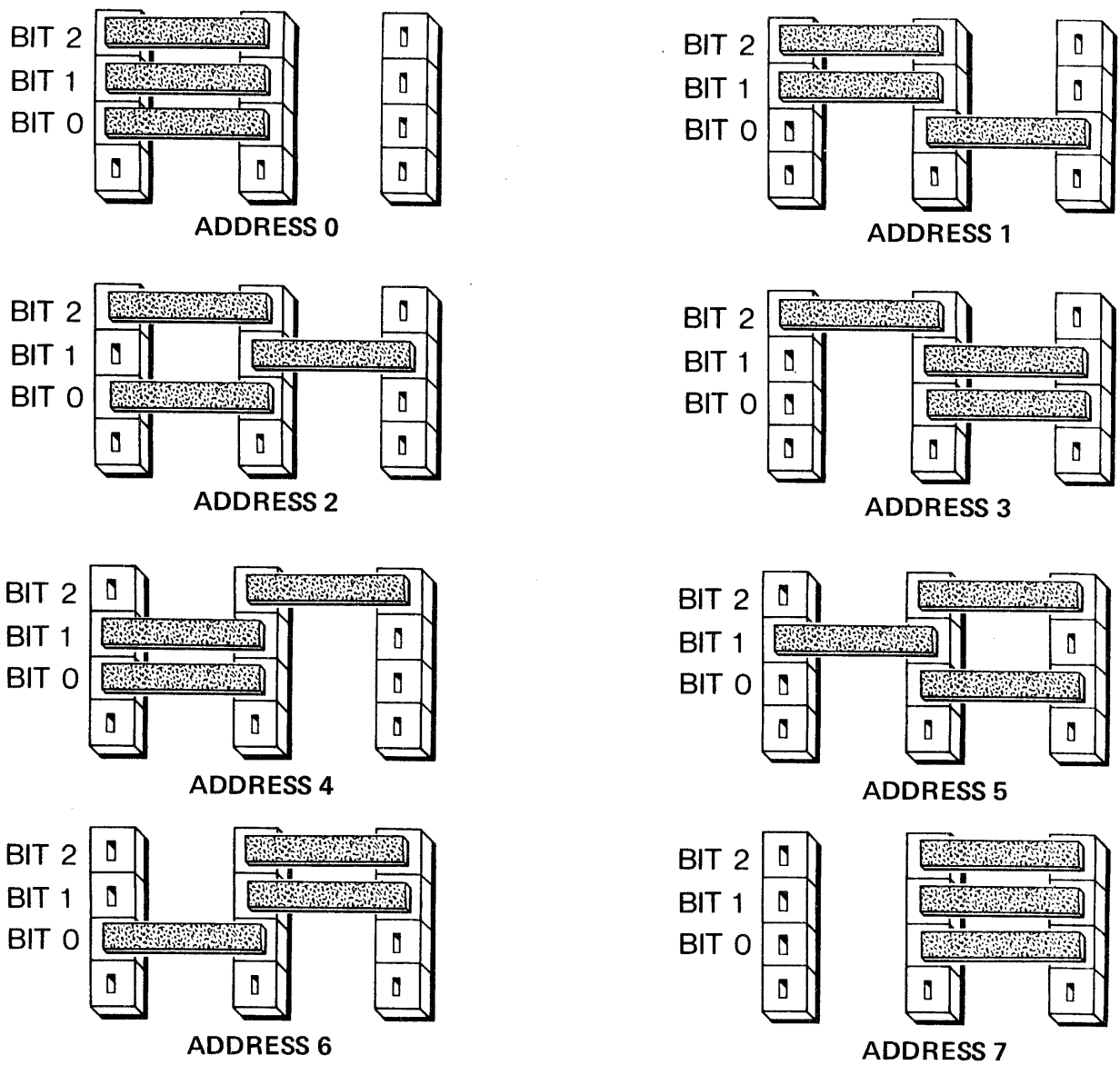

PB001625-2

**NOTE**

New A1A11 PCAs have rotary switches for drive addressing, instead of jumpers.

Figure 2-5-2-1-B Drive Address Configurations



The serial number of each drive falls within the range 0000 - 9999. The following tables indicate where the serial number links are placed.

**Step 1. The "thousands digit" of the serial number.**

<u>If the digit is</u>	<u>Place link across the following pins of A1J26</u>
0 (or not present)	None
1	33-34
2	35-36
3	33-34 and 35-36
4	37-38
5	33-34 and 37-38
6	35-36 and 37-38
7	33-34 and 35-36 and 37-38
8	39-40
9	33-34 and 39-40

**Step 2. The "hundreds digit" of the serial number.**

<u>If the digit is</u>	<u>Place link across the following pins of A1J26</u>
0	None
1	25-26
2	27-28
3	25-26 and 27-28
4	29-30
5	25-26 and 29-30
6	27-28 and 29-30
7	25-26, 27-28, and 29-30
8	31-32
9	25-26 and 31-32

Figure 2-5-2-1-C Serial Number Connecting Links

**Step 3. The "tens digit" of the serial number.**

<u>If the digit is</u>	<u>Place link across the following pins of A1J26</u>
0	None
1	17-18
2	19-20
3	17-18 and 19-20
4	21-22
5	17-18 and 21-22
6	19-20 and 21-22
7	17-18, 19-20 and 21-22
8	23-24
9	17-18 and 23-24

**Step 4. The "units digit" of the serial number.**

<u>If the digit is</u>	<u>Place link across the following pins of A1J26</u>
0	None
1	9-10
2	11-12
3	9-10 and 11-12
4	13-14
5	9-10 and 13-14
6	11-12 and 13-14
7	9-10, 11-12 and 13-14
8	15-16
9	9-10 and 15-16

Figure 2-5-2-1-D Serial Number Connecting Links

**2.6 POWER VERIFICATION**

Prior to cable connection, power verification must be performed. Power conversions are discussed in Subsection 2.7.

**2.6.1 60 Hz Power**

Visually verify that both drive nameplate and frequency label on AC Power Distribution Assembly are marked 60 Hz.

See Figure 2-6-1, AC Power Distribution Assembly (A2) and Transformer Assembly (A10).

Visually verify that AC Interconnect Harness from A2J5 is connected to correct terminals on Transformer Terminal Strip (A10TB1). See Table 2-6-1.

Table 2-6-1 60 Hz Verification

Input Voltage	A10TB1 Terminals
200/208	1* and 2
220	1* and 3
240	1* and 4

\*Terminal one (1) is common.

If terminals at A10TB1 are incorrectly connected, see Subsection 2.7.1, Voltage Level Conversion.

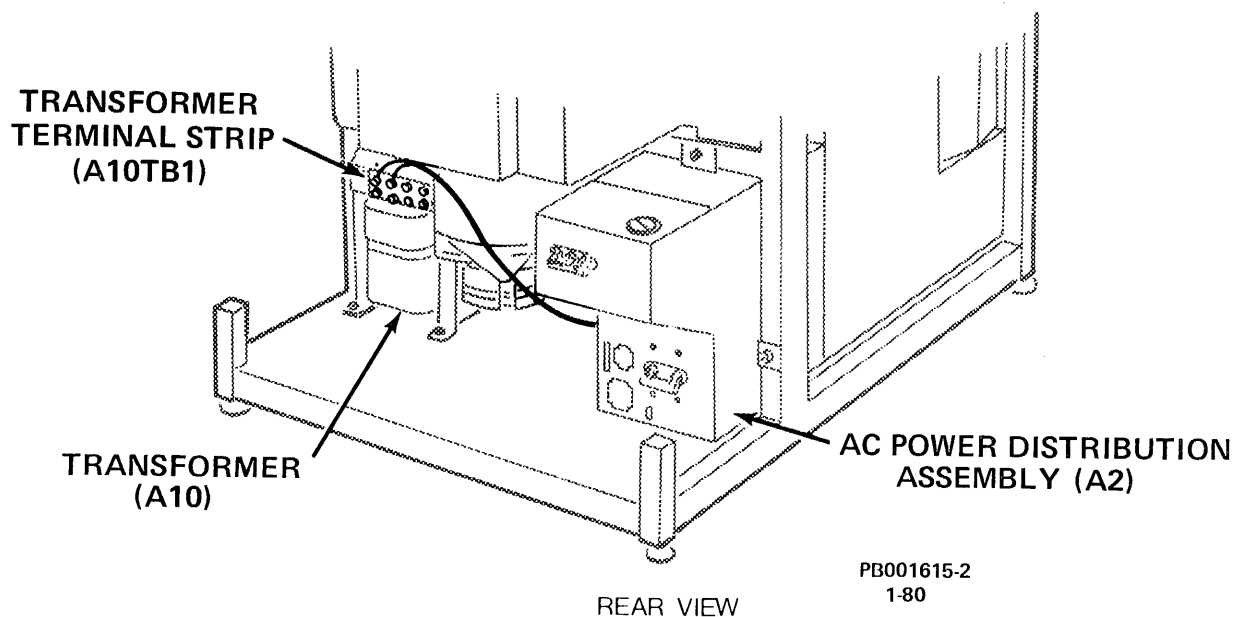

Figure 2-6-1 AC Power Distribution Assembly and Transformer Assembly

### 2.6.2 50 Hz Power

Visually verify that both drive nameplate and frequency label on AC Power Distribution Assembly (A2) are marked 50 Hz.

Visually verify that AC Interconnect Harness from A2J5 is connected to correct terminals on Transformer Terminal Strip (A10TB1). See Table 2-6-2.

Visually verify that the spindle drive motor voltage plug is the correct one for the installation site. This plug is located on the underside of a bracket secured to the bottom of the spindle motor. The plug is marked either 400V (Wye configuration) or 230V (Delta configuration).

#### WARNING

This machine is not UL approved when configured to the following specifications

- 50 Hz Wye - 380/400 volts
- 50 Hz Wye - 400/410 volts
- 50 Hz Delta - 200/208 volts
- 50 Hz Delta - 220 volts
- 50 Hz Delta - 240 volts

Table 2-6-2 50 Hz Verification

Input Voltage	Configuration	A10TB1 Terminals	Time Meter	Jumper
200/208 220 240	Delta	1* and 2	1** and 4	3 and 4
	Delta	1* and 3	1** and 4	3 and 4
	Delta	1* and 4	1** and 4	3 and 4
380/400 400/410	Wye	1* and 3	1** and 2	2 and 3
	Wye	1* and 4	1** and 2	2 and 3

\*Terminal 1 A10TB1 is common to all voltages.

\*\*Terminal 1 A2A1TB1 is common to all configurations.

#### NOTE

To verify correct terminal connection at A2A1TB1 (Table 2-6-2), it is necessary to remove the AC Power Distribution Assembly. See Figure 2-6-2-A, an exploded view of the AC Power Distribution Assembly (A2)

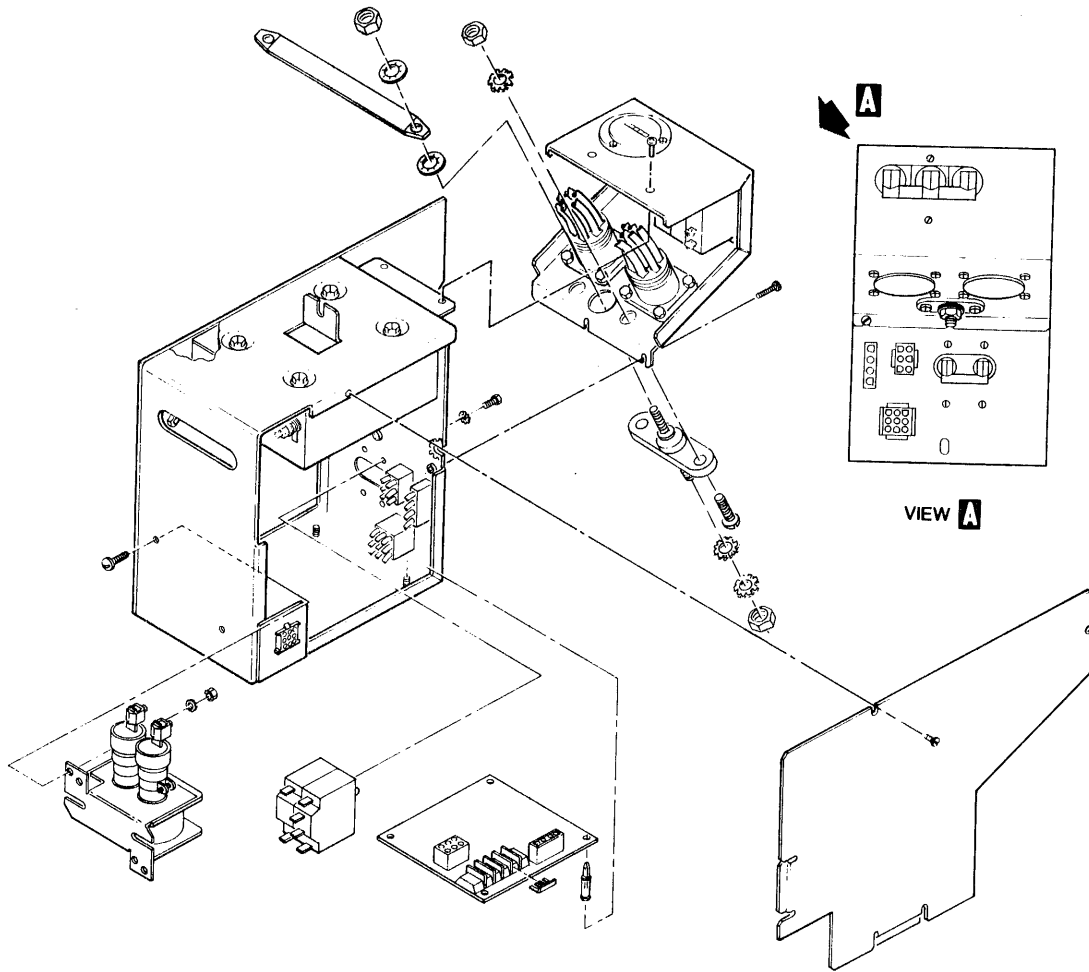

PC035671-1

Figure 2-6-2-A AC Power Distribution Assembly (Exploded View)

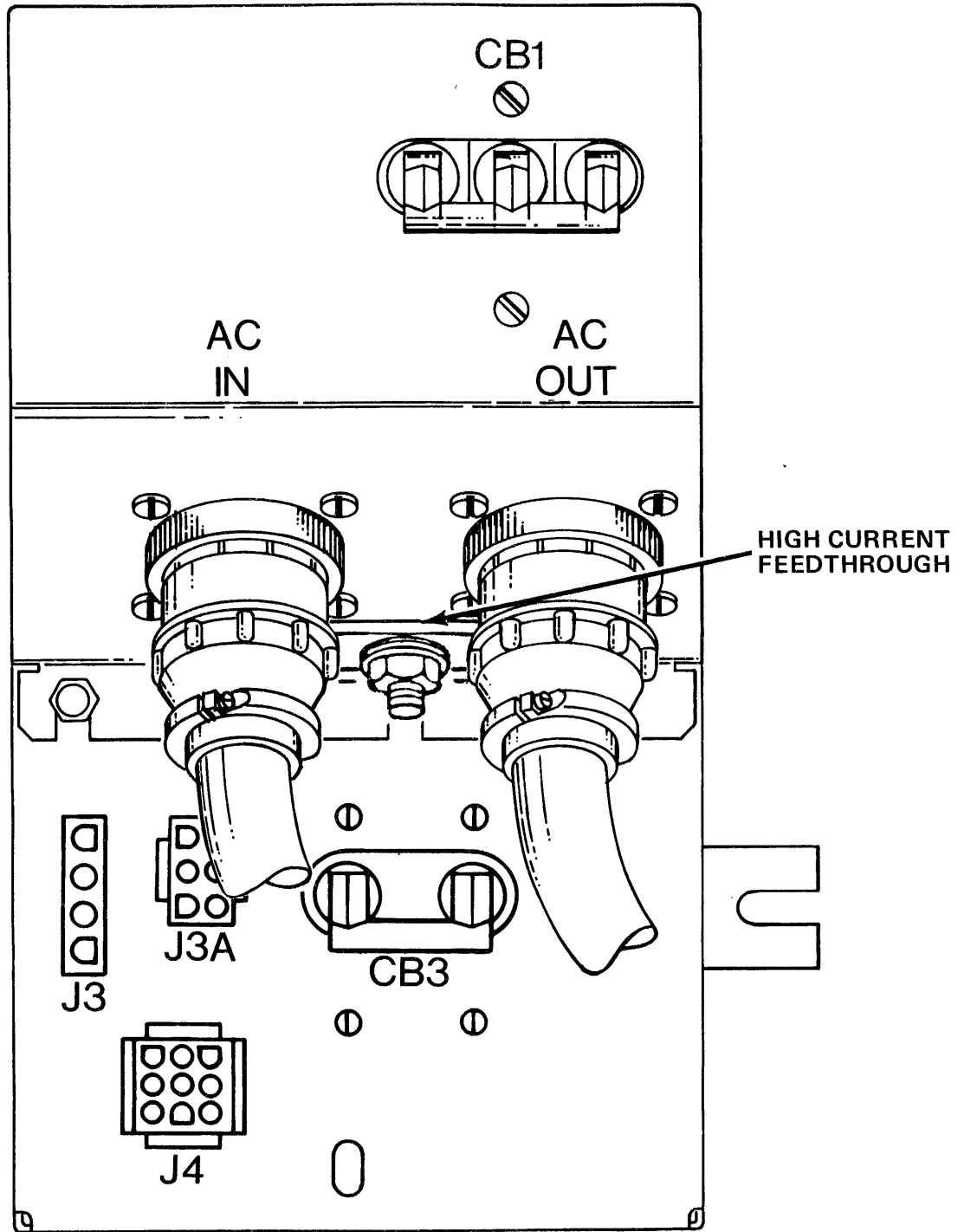

PB001314-2  
12/79

Figure 2-6-2-B AC Power Distribution Assembly (Front View)

1. Disconnect AC/IN (J1), and AC/OUT (J2) connectors (where applicable) from AC Power Distribution Assembly (A2). See Figure 2-6-2-B.
2. Disconnect plug connectors from J3 (J3A where applicable) and J4. See Figure 2-6-2-B.

**NOTE**

J5 connector will be disconnected in step 5.

3. Loosen and remove two screws and lockwashers that secure the AC Power Distribution Assembly to the drive frame.
4. Slowly slide AC Power Distribution Assembly toward rear of drive.
5. Disconnect plug connector from J5.
6. Slide AC Power Distribution Assembly out of drive frame.

If terminals at A10TB1 are incorrectly connected, see Subsection 2.7.1, Voltage Level Conversion.

7. Loosen and remove screws that secure side cover to AC Power Distribution Assembly. Remove cover.
8. Visually verify that the time meter leads and jumper are correctly connected on A2A1TB1. See Table 2-6-2.

If the time meter leads and/or jumper are incorrectly connected, see Subsection 2.7.2, Delta/Wye Conversion.

- 60 Hz (all voltages) and 50 Hz Delta (230 VAC) - Terminals 1 and 4 with the jumper between Terminals 3 and 4.
- 50 Hz Wye (380 VAC) - Terminals 1 and 2 with the jumper between Terminals 2 and 3.

After verification use the following procedure to install the AC Power Distribution Assembly:

1. Replace AC Power Distribution Assembly side cover; replace and tighten screws.
2. Slide AC Power Distribution Assembly half-way into drive frame.
3. Reconnect plug connector to J5.
4. Slide AC Power Distribution Assembly back into drive frame; replace and tighten two screws and lockwashers that secure AC Power Distribution Assembly to drive frame.
5. Reconnect plug connectors to J3 (J3A where applicable) and J4.

6. Reconnect AC/IN, AC/OUT where applicable.

## **2.7 POWER CONVERSIONS**

If drive is not properly configured for the power source input, perform the following steps at designated locations:

### **2.7.1 Voltage Level Conversion - 50 Hz or 60 Hz (at A10TB1)**

1. See Table 2-6-1 for correct 60 Hz wire connections at A10TB1. See Table 2-6-2 for correct 50 Hz wire connections at A10TB1 and A2A1TB1.

#### **NOTE**

Do not change wire on Terminal 1.  
It is common to all voltage ranges.

2. Remove screws on plastic terminal strip shield; remove shield.
3. Loosen (do not remove) terminal screw holding incorrect wire connection.
4. Loosen (do not remove) terminal screw at correct terminal location.
5. Slip wire from incorrect terminal screw and place under correct terminal screw.
6. Tighten terminal screws.
7. Reinstall and secure plastic terminal strip shield.

### **2.7.2 Delta/Wye Conversion - 50 Hz**

#### **NOTE**

Delta/Wye conversion for 60 Hz is not needed.

1. See Table 2-6-2 for correct 50 Hz wire connections at A2A1TB1. See Figure 2-6-2-A, AC Power Distribution Assembly (A2) Exploded. See Block Diagram Figures 2-7-2-A, Delta Configuration, and 2-7-2-B, Wye Configuration.
2. Once AC Power Distribution Assembly (A2) has been removed from drive, loosen two screws that secure side cover to AC Power Distribution Assembly.
3. Remove side cover.

#### **NOTE**

DO NOT change wire on Terminal 1 A2A1TB1. It is common to all configurations.

4. Loosen (do not remove) terminal screw at correct terminal location.
5. Move wire and/or jumper from incorrect terminal screw and place under correct terminal screw.



50 HZ DELTA CONFIGURATION

A2A1TB1

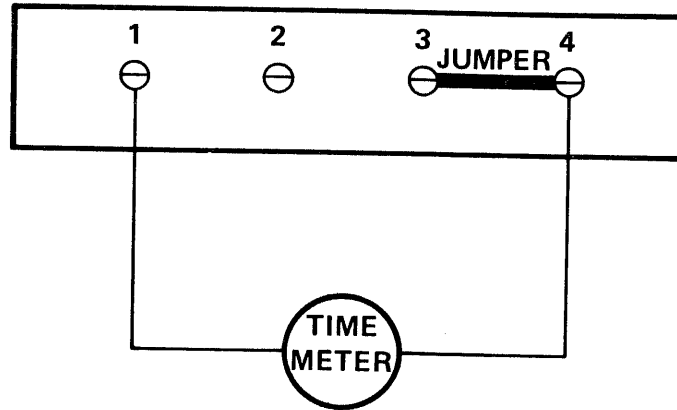

PB001631-4

Figure 2-7-2-A 50 Hz Delta Configuration

50 HZ WYE CONFIGURATION

A2A1TB1

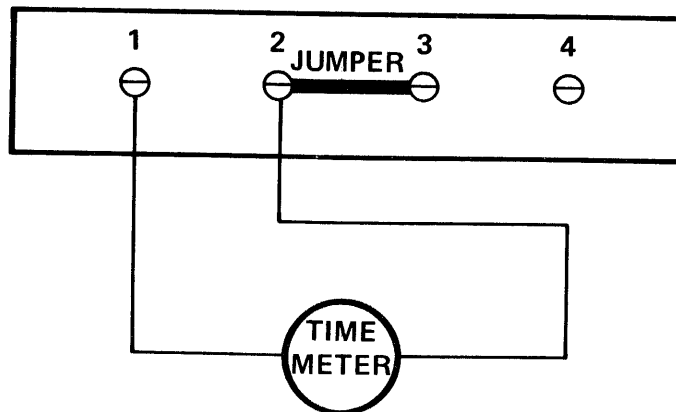

PB001631-5

Figure 2-7-2-B 50 Hz Wye Configuration

6. Tighten terminal screws.
7. Reinstall and resecure plastic terminal strip shield.

When converting from Delta to Wye or Wye to Delta, the time meter lead connections must be changed. Use the following instructions:

- For Delta to Wye conversions move the time meter lead from TB1 Terminal 4 to Terminal 2. Move the jumper bridging Terminals 3 and 4 to Terminals 2 and 3.
- For Wye to Delta conversions move the time meter lead from TB1 Terminal 2 to Terminal 4. Move the jumper bridging Terminals 2 and 3 to Terminals 3 and 4.

Install the AC Power Distribution Assembly using the following procedure:

1. Reinstall AC Power Distribution side cover; tighten screws.
2. Slide AC Power Distribution Assembly half-way into drive frame.
3. Reconnect plug connector to J5.
4. Slide AC Power Distribution Assembly back into drive frame; replace and tighten two screws and lockwashers that secure AC Power Distribution Assembly to drive frame.
5. Reconnect plug connectors to J3 (J3A where applicable) and J4.

In addition, the spindle drive motor voltage plug, located on a bracket on bottom of the drive motor must be replaced. This plug must reflect the drive's new voltage configuration; either 400V (Wye configuration) or 230V (Delta configuration).

### **2.7.3 Frequency Conversion**

A 60 Hz Model RP07 may be converted to a 50 Hz Model.

#### **NOTE**

When performing a 60 Hz to 50 Hz conversion the UL label must be removed.

The following components must be replaced to convert a 60 Hz drive to 50 Hz operation.

<u>Component</u>	<u>Reference Designator</u>
Motor/Brake Assembly	A6A3M1
Blower Assembly	A6A5
Power Transformer Assembly	A10
Time Meter Assembly	A2TT1
Belt, Flat	-
Spring, Extension, Belt	-
Label, Frequency Designation 50 Hz	-
Label, Identification 50 Hz	-
Label, 50 Hz	-
AC Power Cable	-
Motor Voltage Plug (50 Hz only)	-

Reference the Service Manual for Removal and Replacement procedures for the above assemblies.

## 2.8 CABLE CONNECTION

This section contains procedures for cable connection.

### NOTE

Insure that power verification is performed before proceeding. See Subsection 2.6 of this manual.

#### Power Cable Connection

- AC Power Cable
- AC Ground Cable
- DC Ground Cable
- Power Sequence Cable

#### Massbus Cable Connection

- Single Port
- Dual Port

The following is a list of external cable assemblies for RP07:

#### Cable Assembly

AC DRIVE TO DRIVE  
AC POWER BOX TO DR 0  
AC POWER TO 60 HZ  
AC POWER TO 50 HZ  
DC GROUND  
POWER SEQUENCE  
MASSBUS

Part numbers for external cables are listed in the Illustrated Parts Breakdown (ER-0RP07-IP), index 2.1

### 2.8.1 Power Cable Connectors

The following procedures provide cable connections for power distribution, ground, and sequencing.

#### 2.8.1.1 AC Power Cable Connection - AC cables may be connected:

1. INDIVIDUALLY to main power source at wall socket.
2. DAISY CHAINED to adjacent RP07, three maximum.

#### **WARNING**

CBI must be OFF or personal injury may result.

See Figure 2-8-1-1 for an illustration of cable connectors on AC Power Distribution Assembly (A2).

AC/IN (A2J1): AC power is connected to drive at AC/IN. Connectors are keyed for proper mating.

AC/OUT (A2J2): AC/OUT is used only in daisy chain configuration. Connectors are keyed for proper mating.

#### Individually Connecting a Drive:

1. Verify that CBI is OFF.
2. Connect AC cable to drive at AC/IN.
3. Connect AC cable to main power source at wall socket.
4. Verify that both connectors are secure.

#### Daisy Chaining Drives:

#### **NOTE**

For daisy chain configuration, AC cables lie on frame bottom of each drive.

1. Verify that CBI is OFF.
2. Plug AC cable into AC/OUT of first drive in daisy chain.
3. Plug same AC cable into AC/IN of second drive in daisy chain.
4. Repeat above steps for chain of three drives maximum (first drive in chain connected to the main power source).

#### **NOTE**

AC phases are rotated in the drive through the AC/IN and AC/OUT connectors.

5. Plug AC cable from AC/IN of first drive to main power source at wall socket.

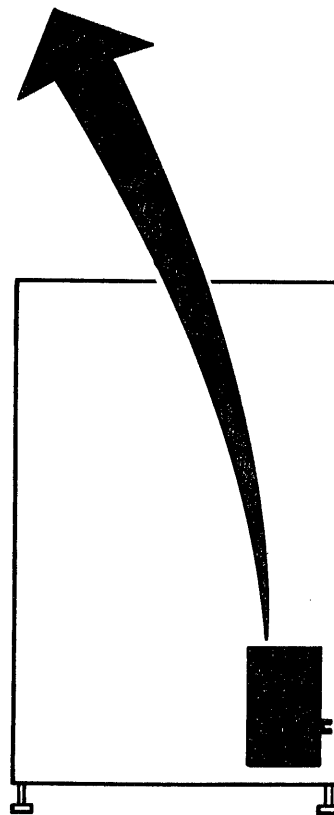
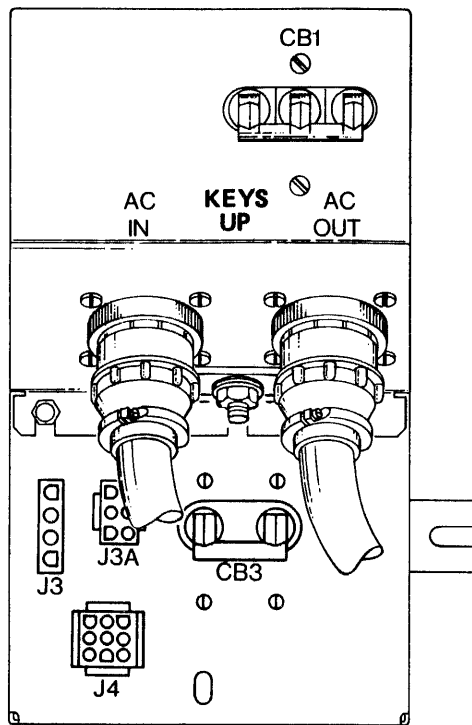

PB001607-1  
1/80

Figure 2-8-1-1 AC Power Cable Connections

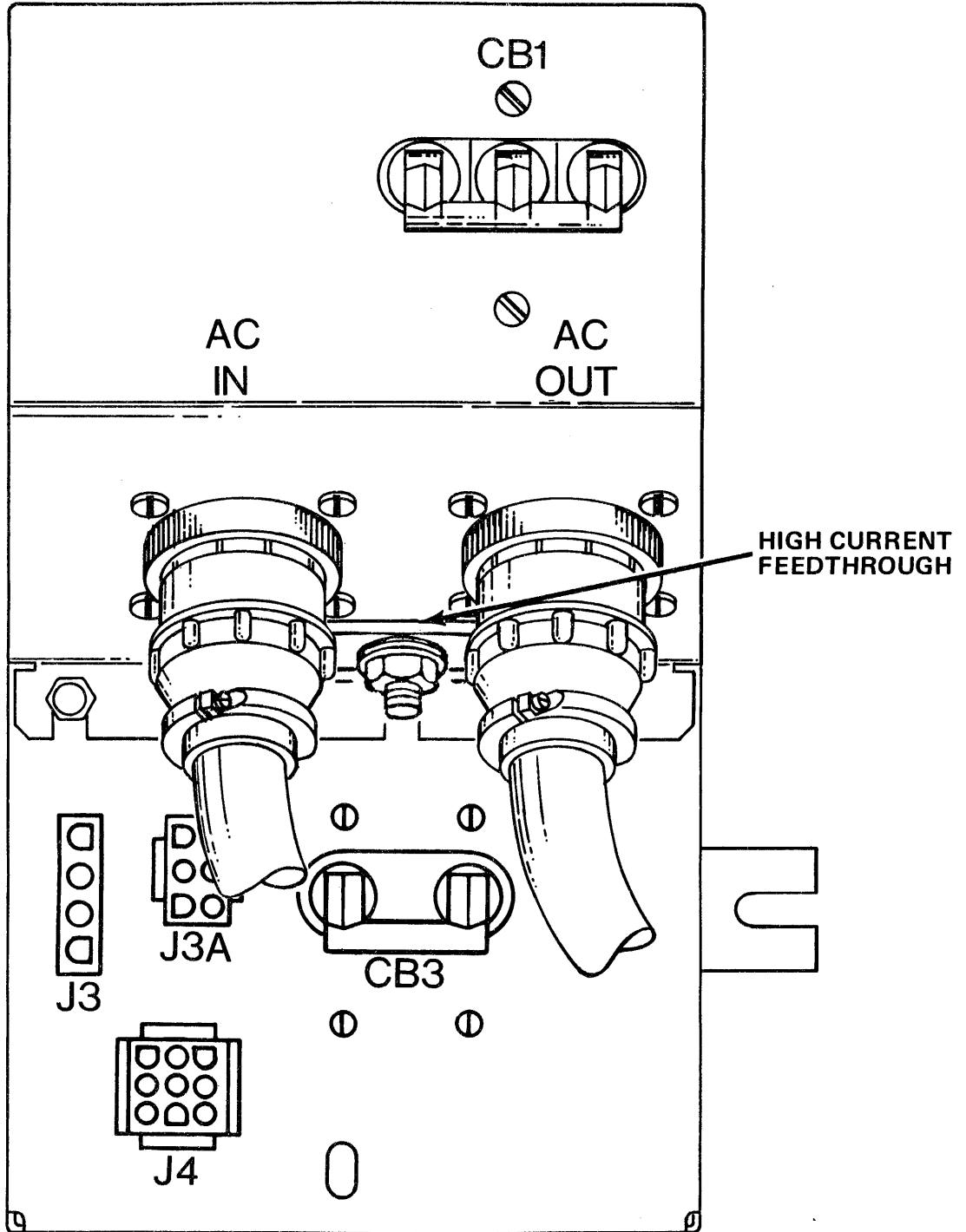

PB001314-2  
12/79

Figure 2-8-1-2 AC Ground Strap Connection

6. Verify that all connections are secure.

**2.8.1.2 AC Ground Cable Connection** - See Figure 2-8-1-2 for an illustration of the AC ground strap connection.

**NOTE**

AC ground is used to ground RF interference from the AC line.

After connecting the AC power cable connector to AC/IN (A2J1), secure the AC ground strap as follows:

1. Loosen and remove the nut and two (2) lockwashers from the AC Power Distribution Assembly high current feed through.
2. Install AC ground strap to high current feed through.
3. Replace the two (2) lockwashers and the nuts.

**2.8.1.3 DC Ground Cable Connection** - One DC ground cable is provided with each drive. See Figure 2-8-1-3 for illustration of DC ground cable connection.

**WARNING**

DC grounds must be correctly installed or erratic subsystem operation may result.

DC ground cables are routed through cable tray.

1. Bolt one end of DC ground cable to controller as specified in applicable systems documentation.
2. Bolt other end of DC ground cable to the bolt at the capacitor assembly.
3. Remove the green logic safety ground between the frame and the electronics library.

For Daisy Chained Drives:

4. Bolt DC ground cable to adjacent bolted drive just above cable from last drive (or controller); repeat procedure for remaining drives in string.

For Dual Port Configurations:

5. Bolt the DC ground cable from the second RHXX to the unused DC ground bolt at the capacitor assembly on the last drive in the string. This will effectively tie both controllers and all drives in the string to a common DC ground.

**2.8.1.4 Power Sequence Cable Connection** - One power sequence cable is provided with each drive. Connector housing at both ends are male 4-pin Mate-N-Lock.

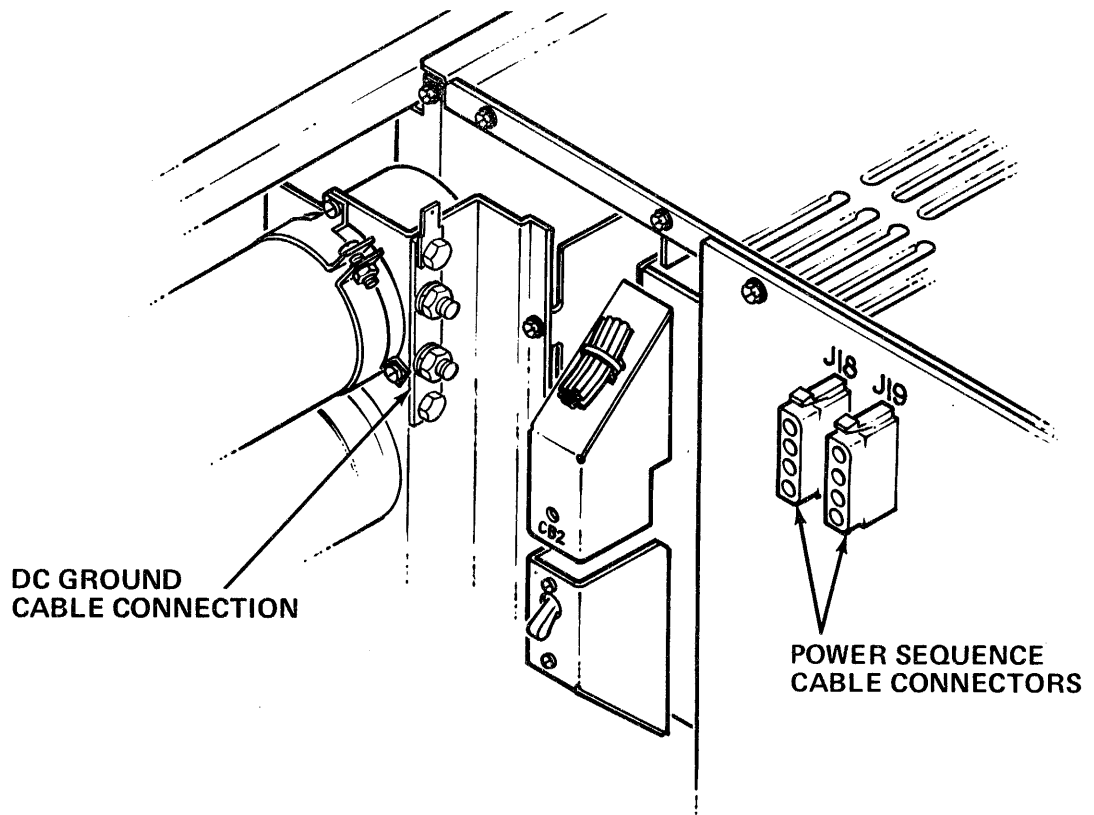

PB001612-1

Figure 2-8-1-3 DC Ground Strap Connection

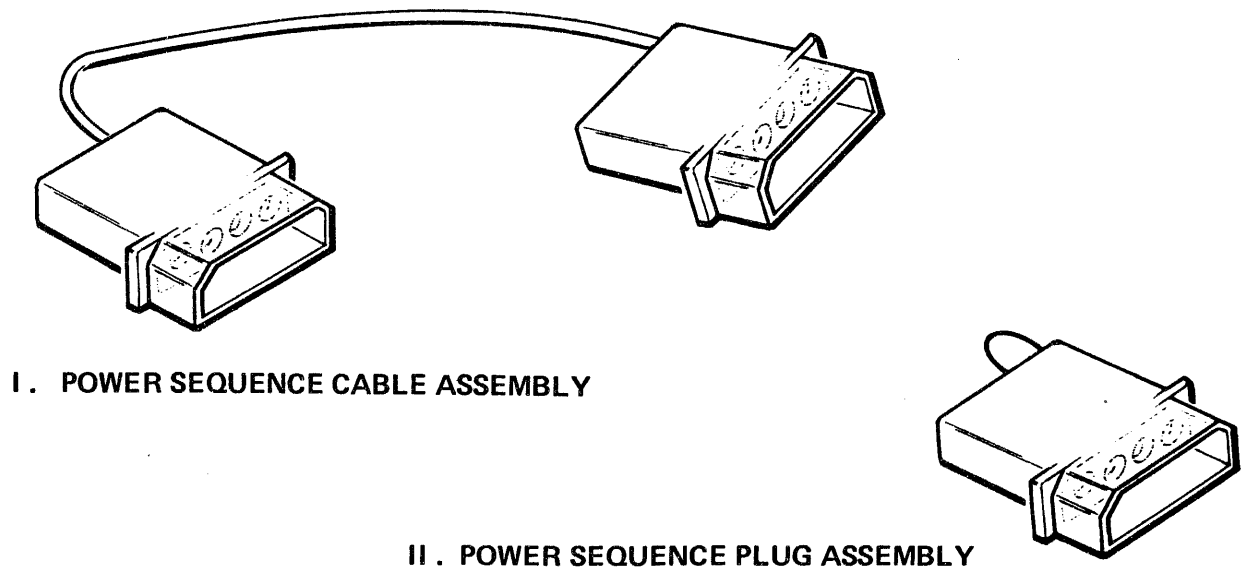

Figure 2-8-1-4-A Power Sequence Plug and Cable Assembly



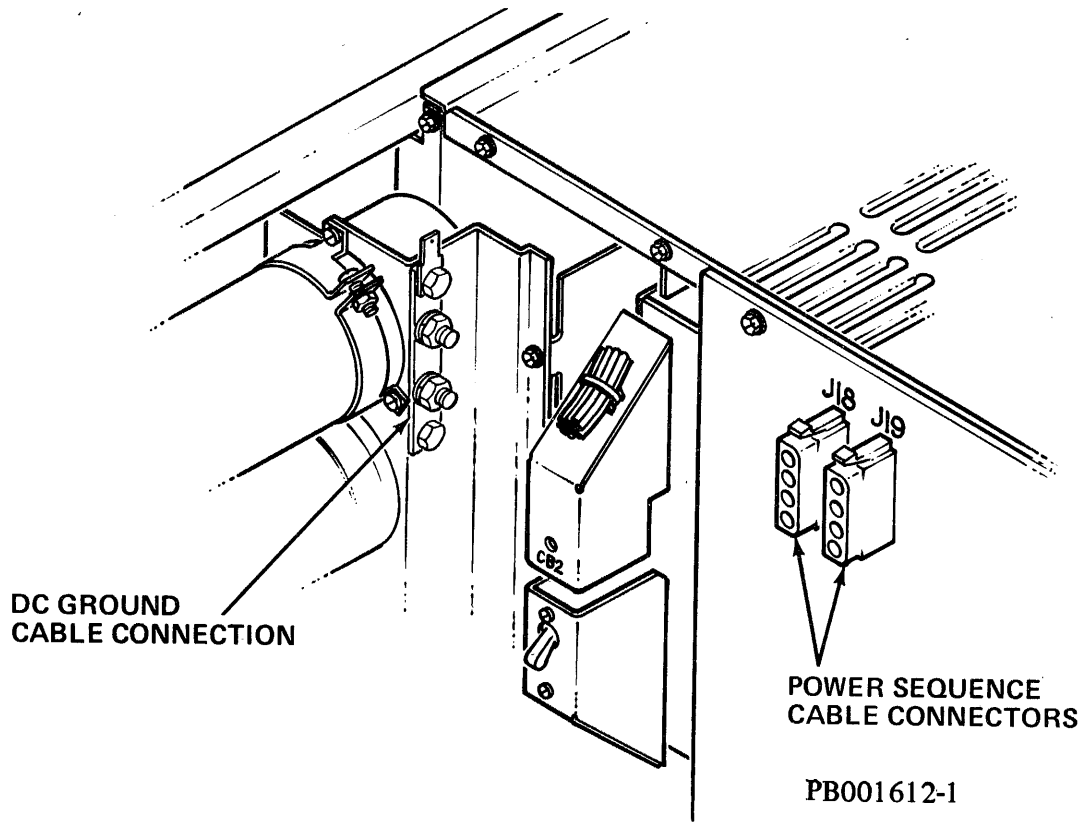

Figure 2-8-1-4-B Power Sequence Connections on Backpanel

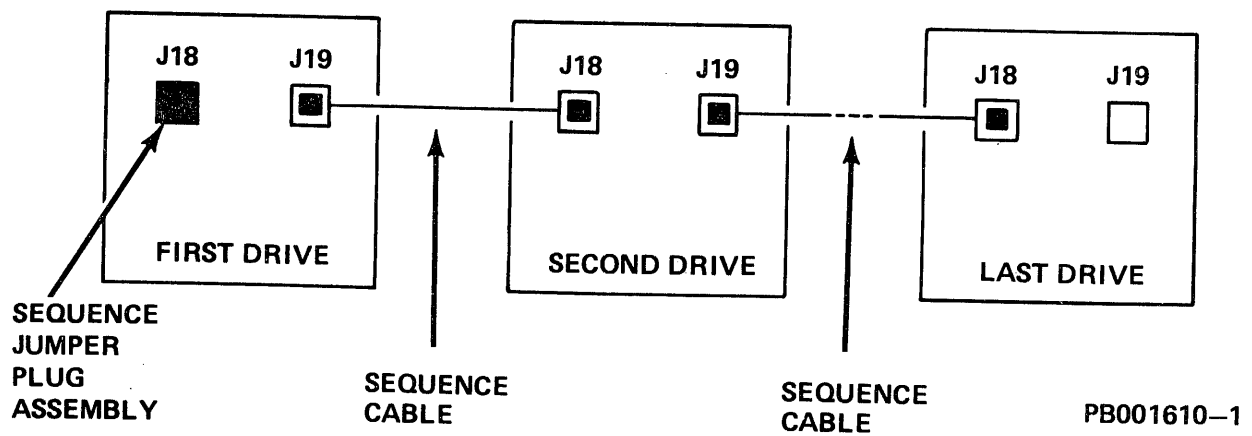

Figure 2-8-1-4-C Sequence Cable Interconnect

- Pin #4: Ground
- Pin #3: SGI (Start Grant In) or SGO (Start Grant Out)
- Pin #2: SIP (Start In Progress)
- Pin #1: Not Used

See Figure 2-8-1-4-A for illustration of sequence cable and sequence jumper plug assembly.

See Figure 2-8-1-4-B for illustration of power sequence cable connections on backpanel.

See Figure 2-8-1-4-C for sequence cable interconnect diagram.

#### Connecting One Drive:

Connect Sequence Jumper Plug Assembly to J18 of first drive.

#### Connecting Two or More Drives:

1. Connect Sequence Jumper Plug Assembly to J18 of first drive.
2. Connect one end of the Power Sequence Cable Assembly to J19 of first drive.
3. Connect the other end of cable to adjacent drive backpanel J18.
4. Continue connecting cables from J19 of preceding drive to J18 of next drive.

#### **NOTE**

J19 of last drive in line will be empty.

### **2.8.2 Massbus Cable Connection**

RP07 drives are shipped with internal Massbus ribbon harness connected. External Massbus cables must be connected for either single or dual port operation. See Figure 2-8-2-A for illustration of Massbus cable and connection point on cable tray backplate. See Figure 2-8-2-B for illustration of location of Massbus connectors on cable tray (A9) backplate.

**2.8.2.1 Single Port Connection** - Massbus cable is connected at connector marked A-IN/A-OUT on cable tray (A9) backplate. All cables are routed through cable tray. See Figure 2-8-2-1.

#### Connecting One Drive to One Controller:

1. Connect Terminator to A-OUT. Lock.
2. Connect Massbus cable to A-IN. Lock.
3. Connect the other end of the Massbus cable to controller as specified in applicable systems documentation.

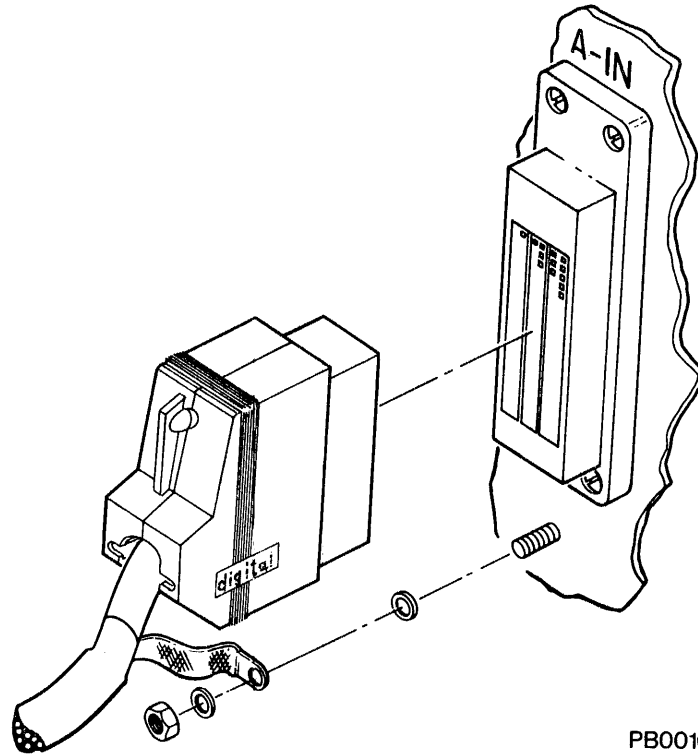

Figure 2-8-2-A Massbus Connector

Connecting Two or More Drives to One Controller (Daisy Chain Configuration):

1. Begin at RP07 farthest from controller.
2. Connect Terminator to A-OUT. Lock.
3. Connect one end of appropriate length Massbus cable to A-IN. Lock.
4. Connect other end of same cable to A-OUT of adjacent drive. Lock.
5. Connect another appropriate length Massbus cable to A-IN. Lock.
6. Connect other end of same cable to controller as specified in applicable systems documentation.

MORE THAN TWO DRIVES

7. Continue for all drives until drive closest to controller.
8. Connect controller end of cable as specified in applicable systems documentation.

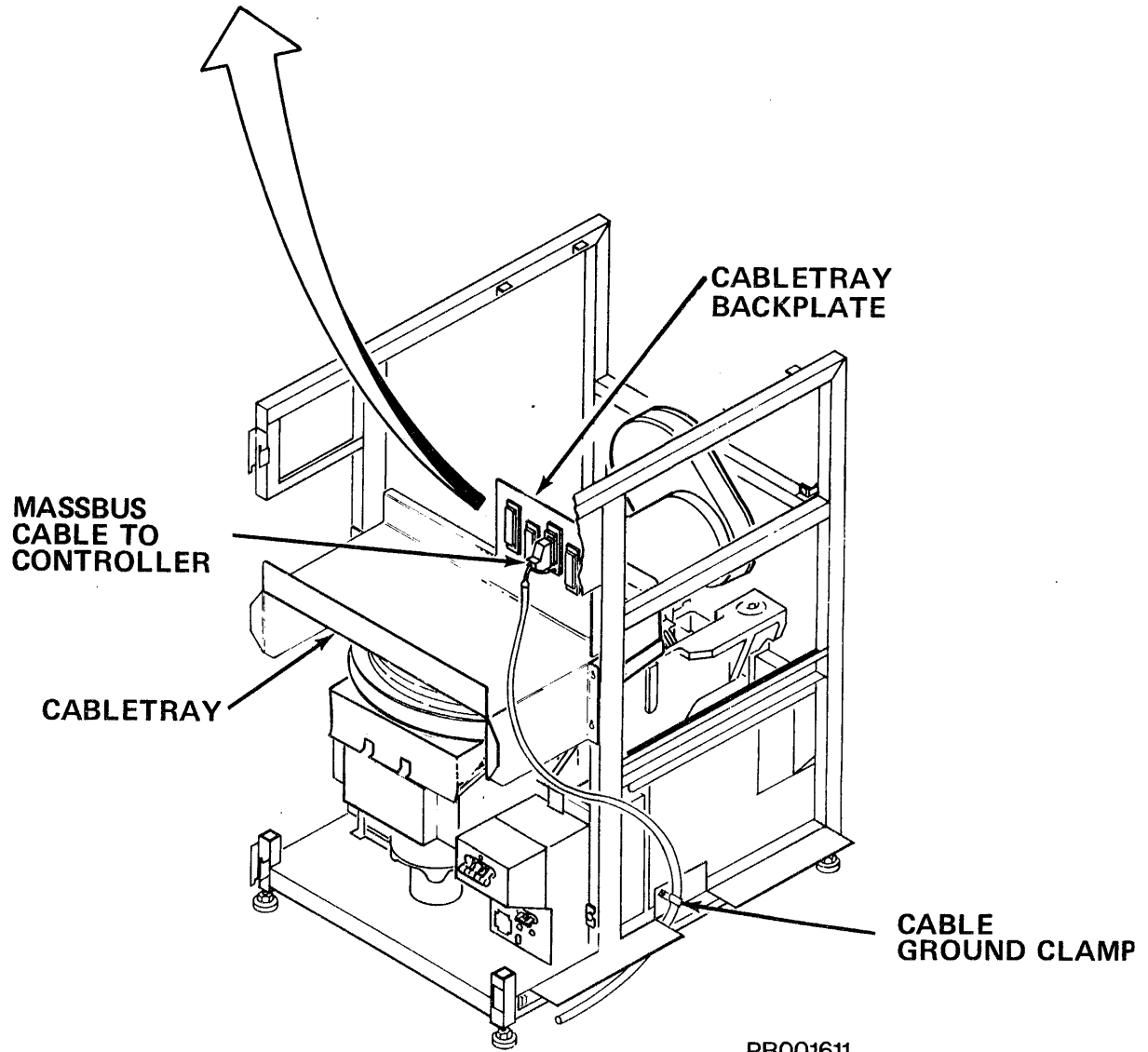
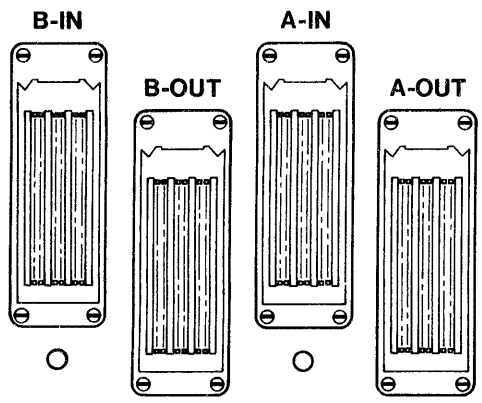

PB001611  
1-80

Figure 2-8-2-B Massbus Connector Location

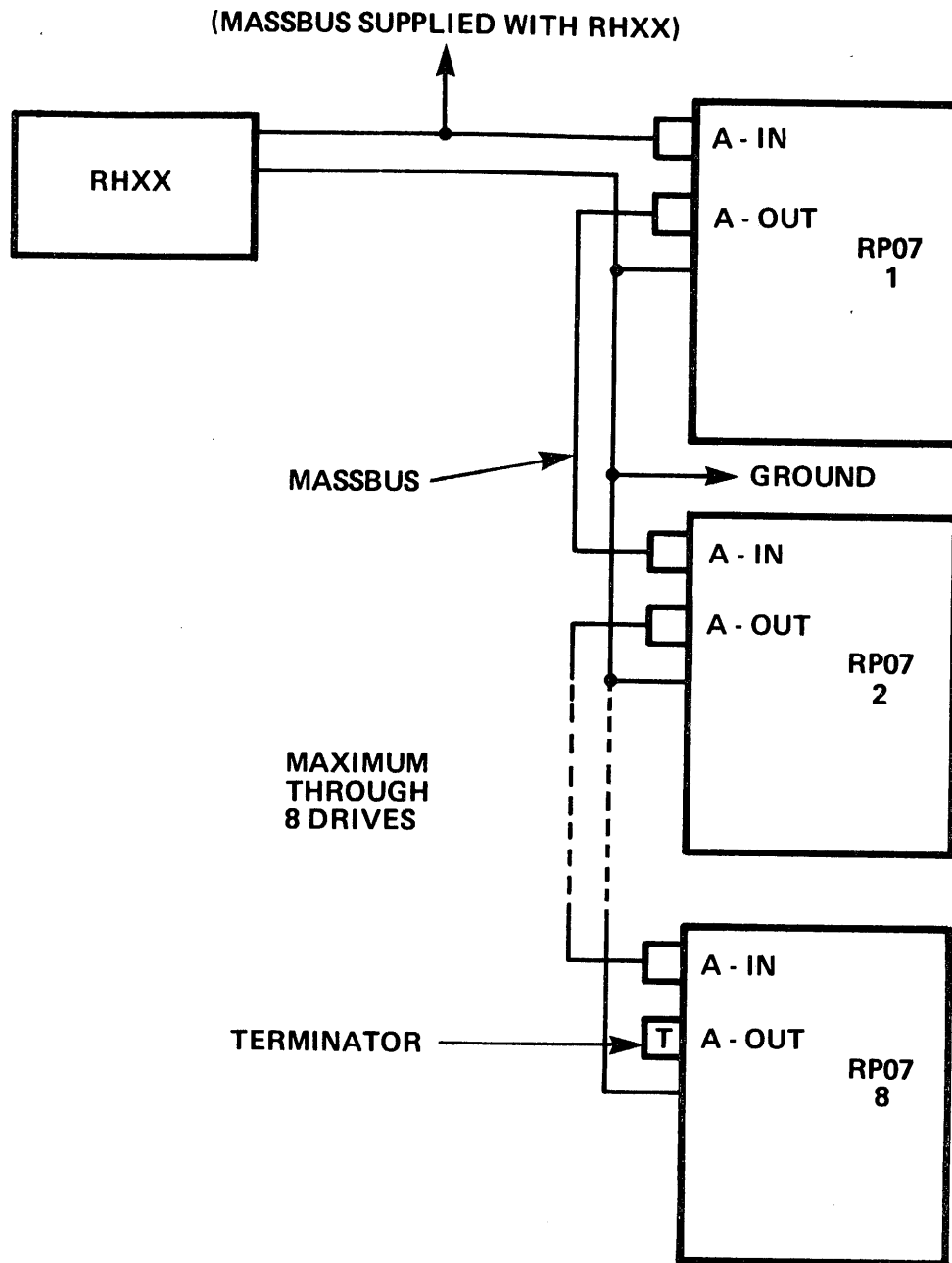

**NOTE:**

- (1) **GROUND CABLE AND MASSBUS SHOULD FOLLOW THE SAME PATH AND MUST BE TIE-WRAPPED TOGETHER.**

PB001871-1

Figure 2-8-2-1 Single Port Massbus Connection

**2.8.2.2 Dual Port Connection** - Massbus cable is connected at connectors marked A-IN/A-OUT and B-IN/B-OUT on cable tray (A9) backplate. All cables are routed through cable tray. See Figure 2-8-2-2 for dual port massbus connections.

Connecting Two Controllers, One Drive:

1. Connect Terminator to A-OUT. Lock.
2. Connect Massbus cable to A-IN. Lock.
3. Connect the other end of the Massbus cable to controller as specified in applicable systems documentation.
4. Connect another Terminator to B-OUT at drive. Lock.
5. Connect another Massbus cable of appropriate length to B-IN at drive. Lock.
6. Connect other end of same cable to controller as specified in applicable systems documentation.

Connecting More Than One Drive to More Than One Controller (Typical):

RH Controller A:

1. Connect Terminator to A-OUT of drive farthest from Controller A (1). Lock.
2. Connect Massbus cable of appropriate length to A-IN of drive farthest from Controller A (1). Lock.
3. Connect other end of the same cable to adjacent drive (2) at A-OUT. Lock.
4. Connect another Massbus cable of appropriate length to A-IN of same drive (2). Lock.
5. Connect other end of the same cable to adjacent drive (3) at A-OUT. Lock.
6. Connect Massbus cable of appropriate length to same drive (3) at A-IN. Lock. Continue until drive closest to Controller A drive (3).
7. Connect other end of cable from A-IN of closest drive to Controller A as specified in applicable systems documentation.

RH Controller B:

8. Connect Terminator to B-OUT of drive farthest from Controller B (1). Lock.
9. Connect Massbus cable of appropriate length to B-IN of drive farthest from Controller B (1). Lock.
10. Connect other end of the same cable to adjacent drive (2) at B-OUT. Lock.

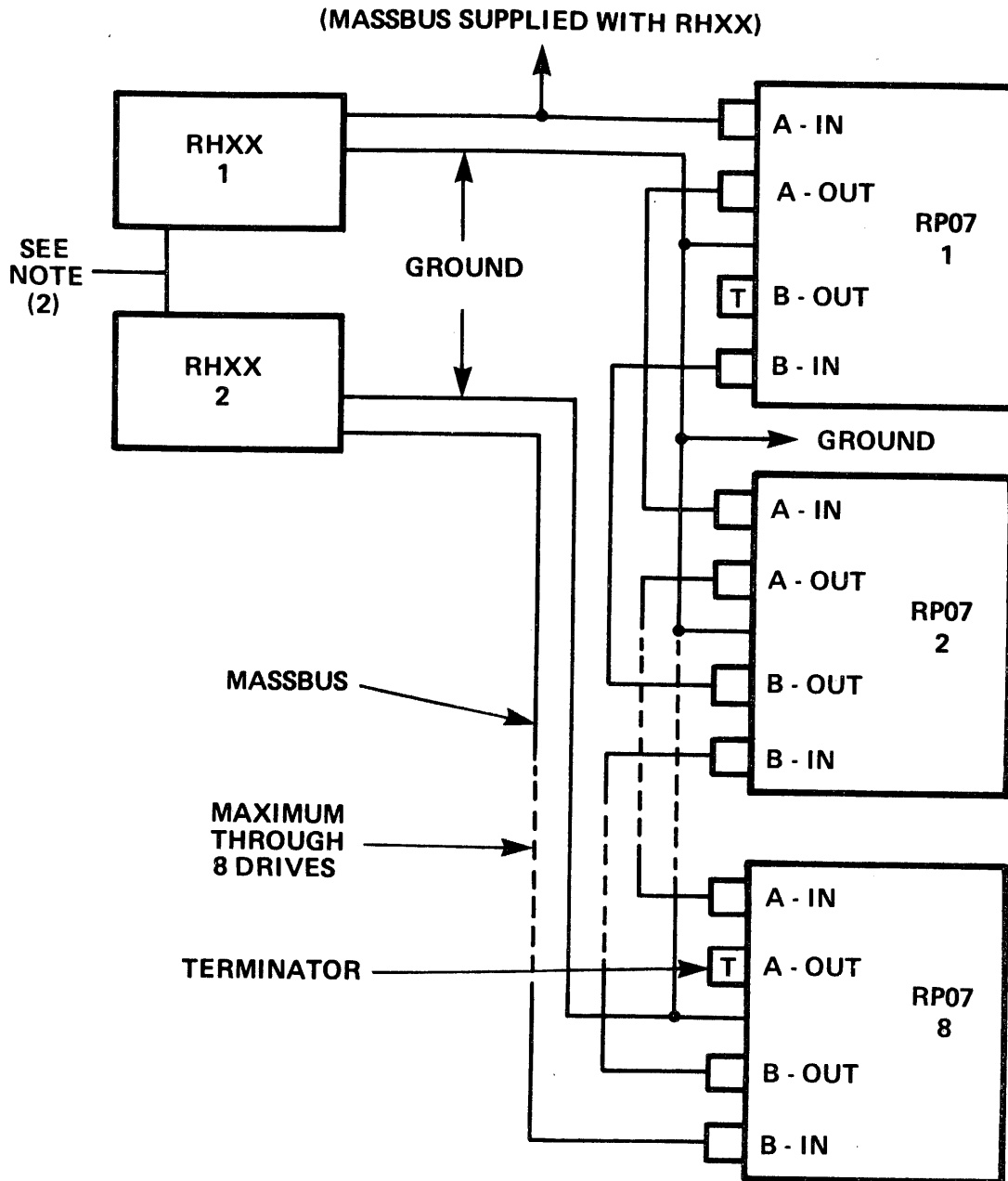

**NOTES:**

- (1) GROUND CABLE AND MASSBUS SHOULD FOLLOW THE SAME PATH AND MUST BE TIE-WRAPPED TOGETHER.
- (2) NO GROUND CONNECTION TO ELIMINATE GROUND LOOPS.

PB001871-4

Figure 2-8-2-2 Dual Port Massbus Connections

11. Connect another Massbus cable of appropriate length to B-IN of same drive (2). Lock.
12. Connect other end of the same cable to adjacent drive (3) at B-OUT. Lock.
13. Connect Massbus cable of appropriate length to same drive (3) at B-IN. Lock. Continue until drive closest to Controller B drive (3).
14. Connect other end of cable from B-IN of closest drive to Controller B as specified in applicable systems documentation.

Massbus cable may be daisy chained for a maximum of eight drives per controller.

### **2.8.2.3 Massbus Grounding Requirements**

In order to meet FCC requirements, the Massbus cable from the RHXX controller to the RP07 disk drive must be grounded in two places. The following procedure should be used to accomplish this:

1. Make the proper Massbus connections at the cable tray backplate.
2. Attach the Massbus grounding pigtail to the backplate. Drive-to-drive Massbus cables will not have the pigtail.
3. Attach the cable mounting bracket to the side of the drive located above the floor cutout.
4. At a point on the Massbus cable at the same height as the cable mounting bracket, cut a one-inch vertical slit in the plastic sheath of the Massbus cable. Avoid cutting too deep, or damage to the ground shield in the cable may result.
5. Slip the cable clamp in between the plastic sheath and the ground shield making certain that the clamp makes good contact with the ground. Bolt the cable clamp to the cable mounting bracket. If this is a dual port drive, repeat the process on the Port 2 Massbus cable.

## **2.9 POWER OFF CHECKS**

This section provides steps following cable installation and prior to initial power up of the RP07. See Figure 2-9-A and 2-9-B for callouts of major assemblies.

### **CAUTION**

Do NOT disconnect cables or harness connector plugs to check their condition unless requested to do so. Cable and harness connectors, jack, plugs and terminals are subject to damage during installation and/or replacement. Care should be used whenever installing, reconnecting and routing cables and harnesses.



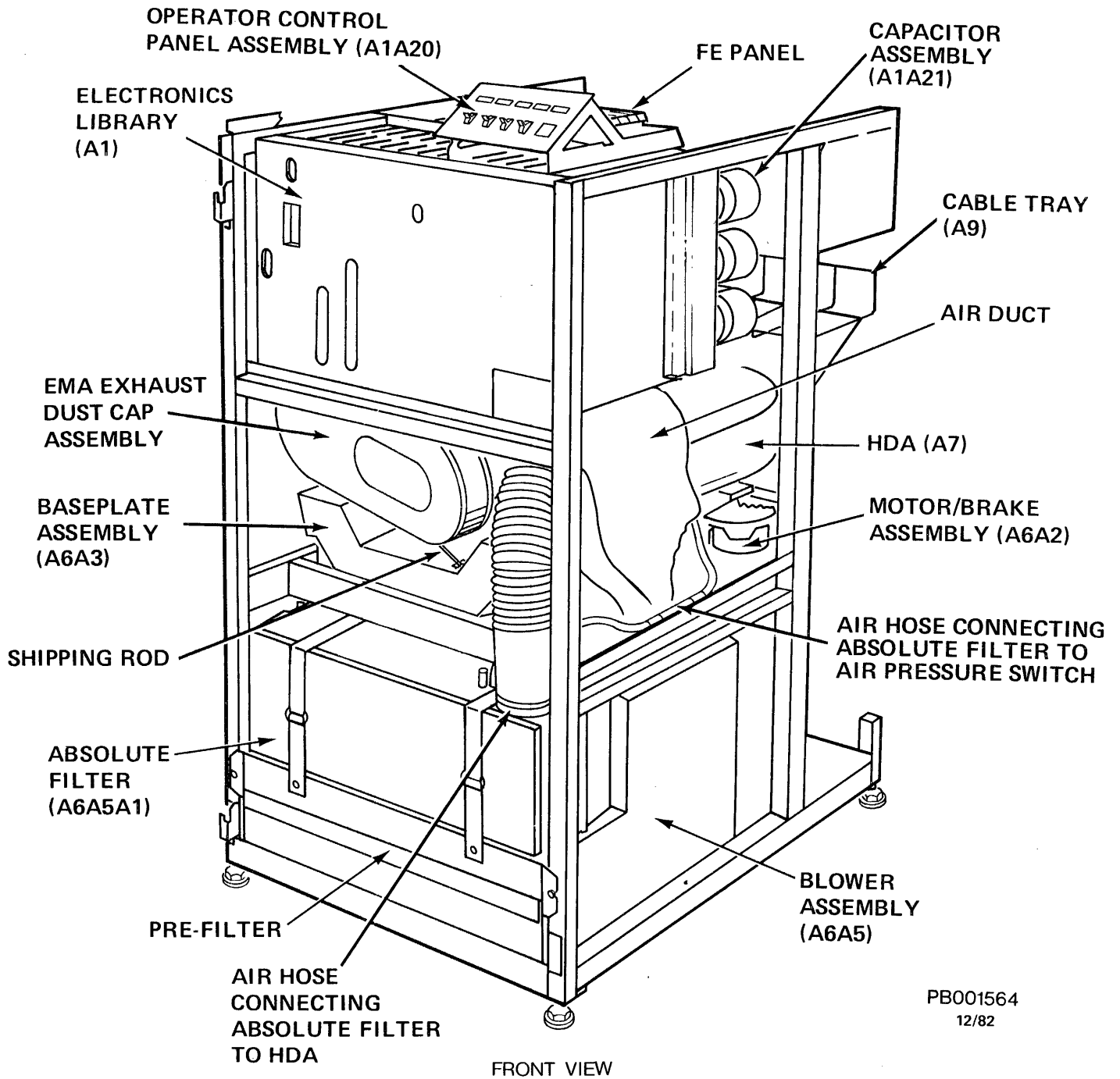
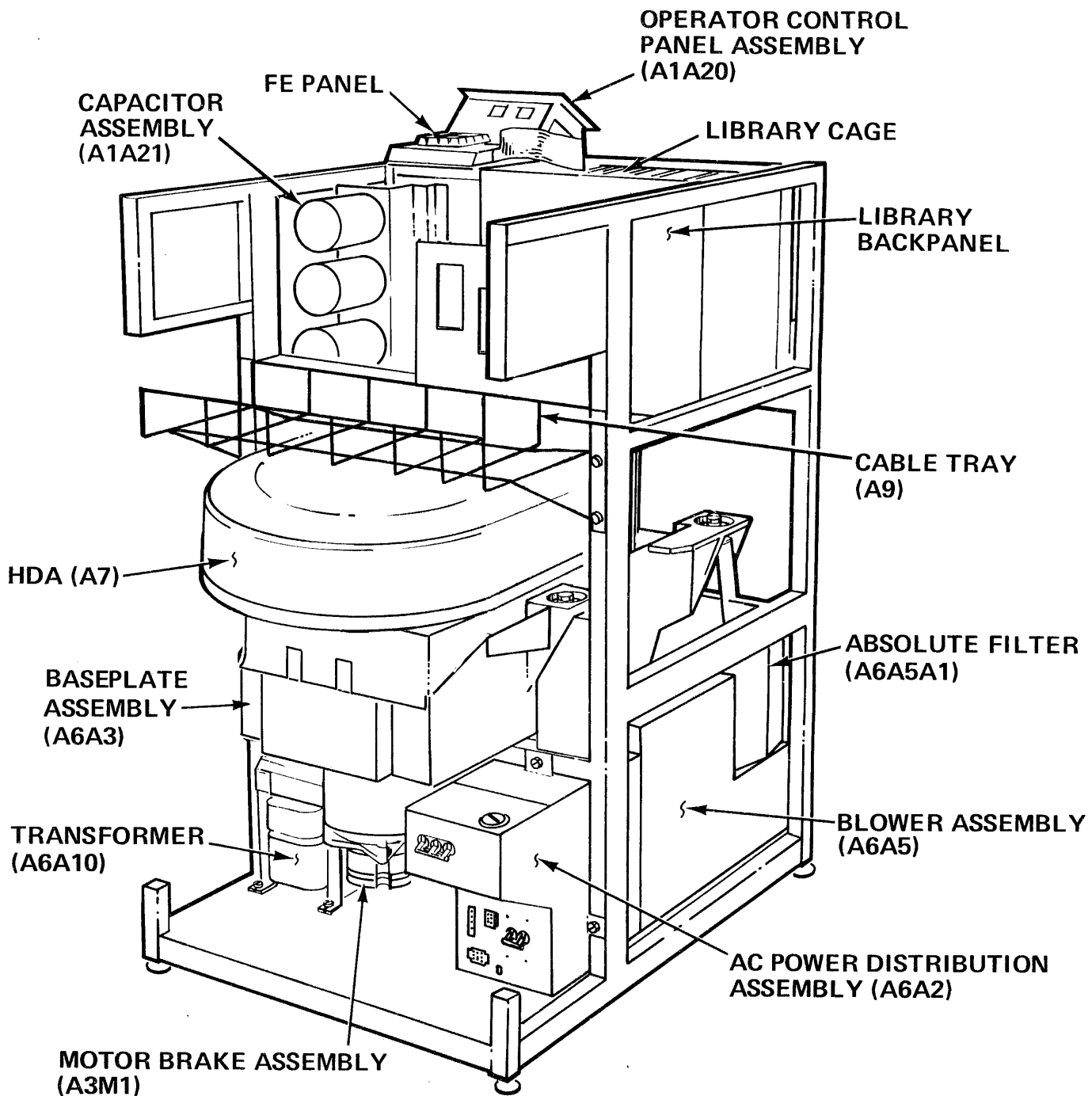

Figure 2-9-A RP07 Front View



PB001565-1  
12/82

Figure 2-9-B RP07 Rear View

1. Visually inspect all cables and harnesses for possible cuts, tears or abrasions. All cables and harnesses should be securely connected.
2. Inspect internal Massbus cable connections at backpanel to insure that they are secure. DO NOT remove connectors.
3. Inspect Absolute Filter air pressure hoses for condition and seating. Insure that the large air hose is properly and securely clamped at both locations.

**CAUTION**

If the large air hose is not properly seated, chafing could occur.

4. Ensure CB4 and CB5 (Rectifier Assembly A1A1) are set ON. Check by pushing in on CB4 and CB5.

**NOTE**

Drive will not power up with CB4 or CB5 tripped OFF.

5. Verify that all drives are level by placing a level on the front and top-side bars of each drive frame.

## **2.10 RH CONTROLLER INFORMATION**

Refer to applicable systems documentation.

## **2.11 POWER UP**

The following steps must be followed to power up an RP07 or a string of RP07s.

**CAUTION**

CB2 must be OFF or damage to the HDA may occur as a result of undesired carriage movement.

1. Set CB1, CB2, CB3, and the Service switch (A1A3 Power Regulator PCA) to OFF.
2. Connect AC power cable to AC power source.
3. Label and disconnect E1 and E2 EMA (Electromagnetic Actuator) leads from backpanel.
4. Place the START/STOP switch in the STOP position.
5. Set FE Mode switch to NORMAL.
6. Set CB1 ON. Blower will begin to operate.
7. Verify that the blower is audible.

8. Set CB3 ON and the Service switch ON (up).

**NOTE**

If the drive comes up "Unsafe" verify that the three phases are sequenced correctly before continuing.

**CAUTION**

1. Do NOT try to correct a voltage out of tolerance. Replace the PCA or drive operation may be impaired.
  2. Verify that the probe being used to test voltages is insulated so that a short between pins cannot occur, or damage to equipment may result.
9. Measure DC voltages. See Table 2-11-A for output voltages, voltage tolerances, and checkpoints.

**Table 2-11-A Voltage Readings**

PIN	NOMINAL VOLTAGE	TOLERANCE
J03004	+22.0V	+1.40V
J03035	+12.0V*	+0.60V
J03123	+15.0V	+0.75V
J03125	-15.0V	+0.75V
J03075	+ 5.0V*	+0.25V
J03110	- 4.065V	+0.11V
J03068	+ 5.0V* Sense	+0.25V
J01117	-48.0V	+2.90V
J03037	-5.0V*	+0.25V

\*+12, +5 and -5 voltages out of tolerance cause CB3 to trip to the OFF position. Verify that voltages are in tolerance by connecting probe to pins.

10. Check the air pressure. Air pressure for the altitude at the installation site should be no less than listed in Table 2-11-B, following.

Table 2-11-B Minimum Air Pressure Requirements

INSTALLATION ALTITUDE		MINIMUM BLOWER PRESSURE AT INSTALLATION INCHES/H <sub>2</sub> O	REPLACE FILTER BEFORE PRESSURE RECORDS INCHES/H <sub>2</sub> O
(FEET)	(METERS)		
0	0	2.50	2.10
1000	305	2.42	2.03
2000	610	2.35	1.97
3000	914	2.28	1.90
4000	1219	2.21	1.84
5000	1524	2.14	1.78
6000	1829	2.07	1.71
7000	2134	2.01	1.66
8000	2438	1.94	1.61
9000	2743	1.88	1.55
10000	3048	1.82	1.50

Air Pressure Check:

- a. With the START/STOP switch OFF, set CBI ON.
- b. Remove the air pressure cap from the outermost air pressure tap, located on top of the Absolute Filter. (See Figure 2-11-A.)
- c. Attach the Air Pressure Gauge Adapter Hose to the air pressure tap.

**NOTE**

Fitting end of Air Pressure Gauge Adapter Hose mates with the Air Pressure Gauge Assembly.

- d. Connect the Air Pressure Gauge Assembly.
- e. Record exhaust pressure.

**CAUTION**

Cap must be replaced immediately to prevent contaminants from entering the air pressure system.

- f. Remove Air Pressure Gauge Assembly and Adapter Hose from air pressure tap, and immediately replace air pressure cap on air pressure tap.

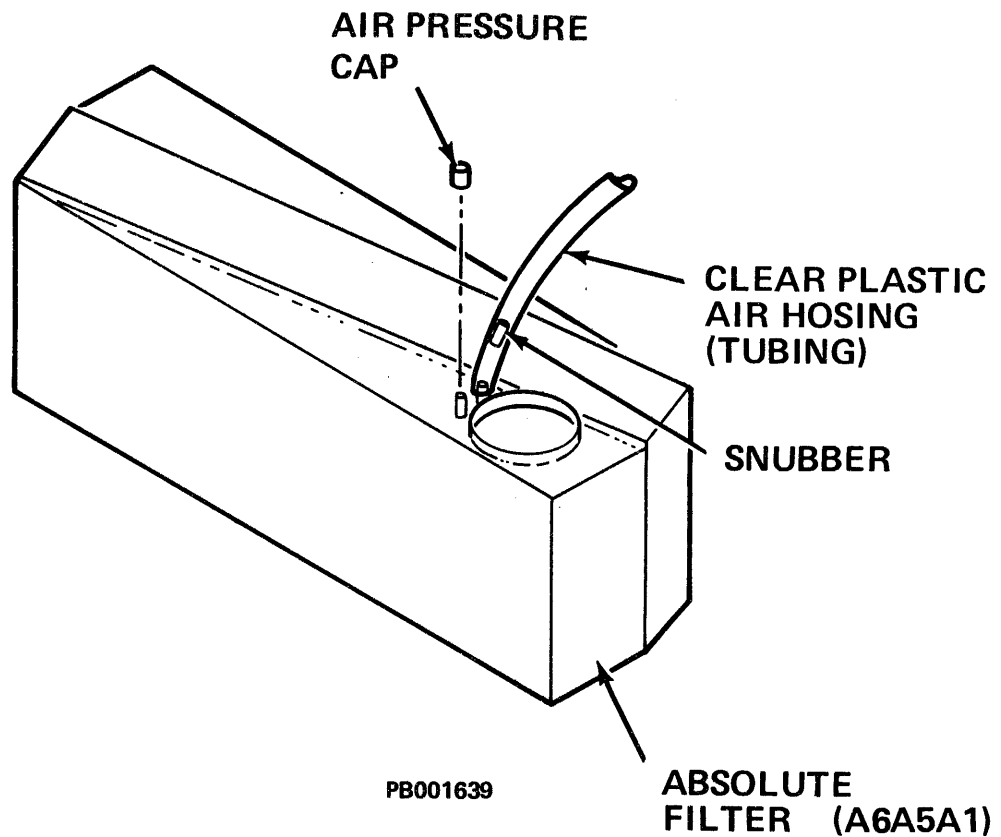

Figure 2-11-A Air Pressure Tap (Absolute Filter)

11. Place START/STOP switch in START.
12. As soon as the stack starts to spin, place FE Mode switch in LOCAL to enable the FE Panel. Power Up Sequence code will appear and will end with error code (Code 4E) signifying that CB2 is OFF. Error code 4E will flash and go away
13. Remove the shipping rod:
 

See Figure 2-11-B.

  - a. Remove tape holding wingnut to crash stop rod.
  - b. Gently loosen shipping rod wingnut (turn counterclockwise).
  - c. Remove shipping rod (turn counterclockwise).
  - d. Store shipping rod in clip provided on the baseplate.

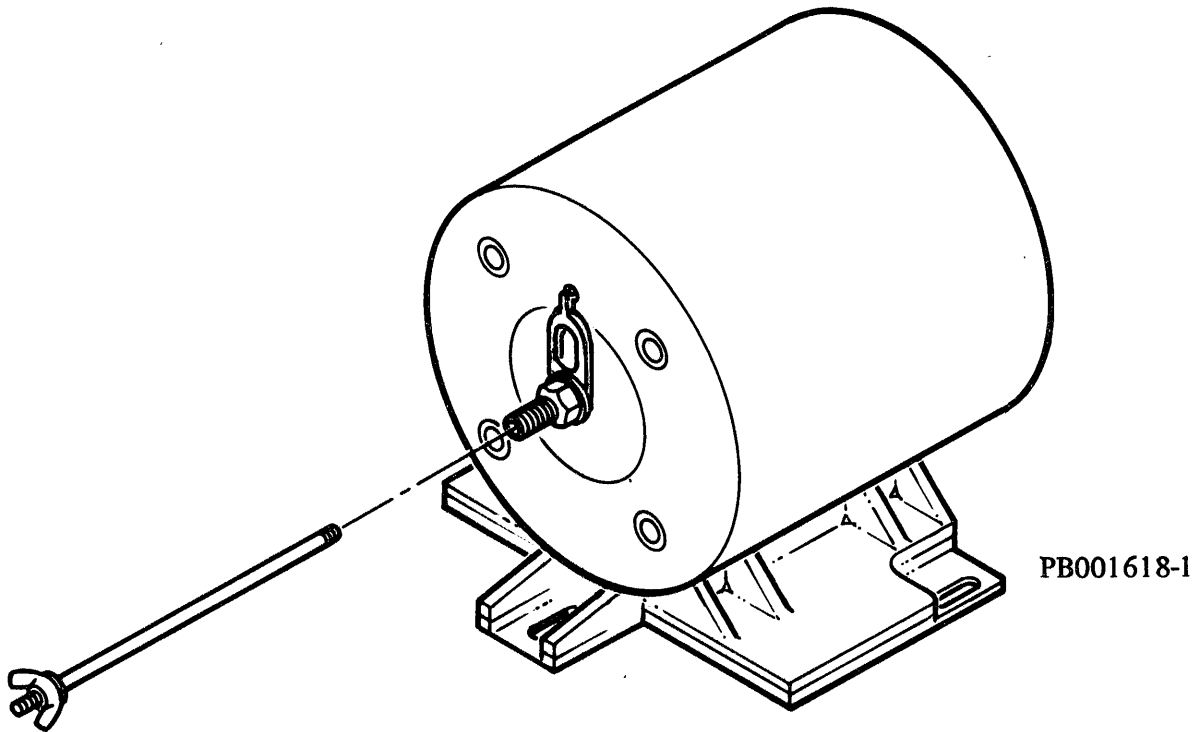

Figure 2-11-B EMA and Shipping Rod

- e. Visually confirm that crash stop locking arm is in the OPERATE (Vertically aligned) position. See Figure 2-11-C.

If the arm is NOT in OPERATE position:

- i. Remove EMA Exhaust Filter.
  - ii. Loosen crash stop retaining nut.
  - iii. Rotate crash stop locking arm clockwise until it is vertically aligned (OPERATE position).
  - iv. Tighten crash stop retaining nut.
  - v. Replace EMA Exhaust Filter.
14. Connect voltage source (1.5V battery; 1.5/3V battery VOM; or 1.5/3V continuity checker) across EMA leads and observe carriage for movement.
    - a. If carriage moves, proceed to step 15. If there is no movement, reverse the leads. If carriage moves after reversal, proceed to step 15.
    - b. If there is still no movement:

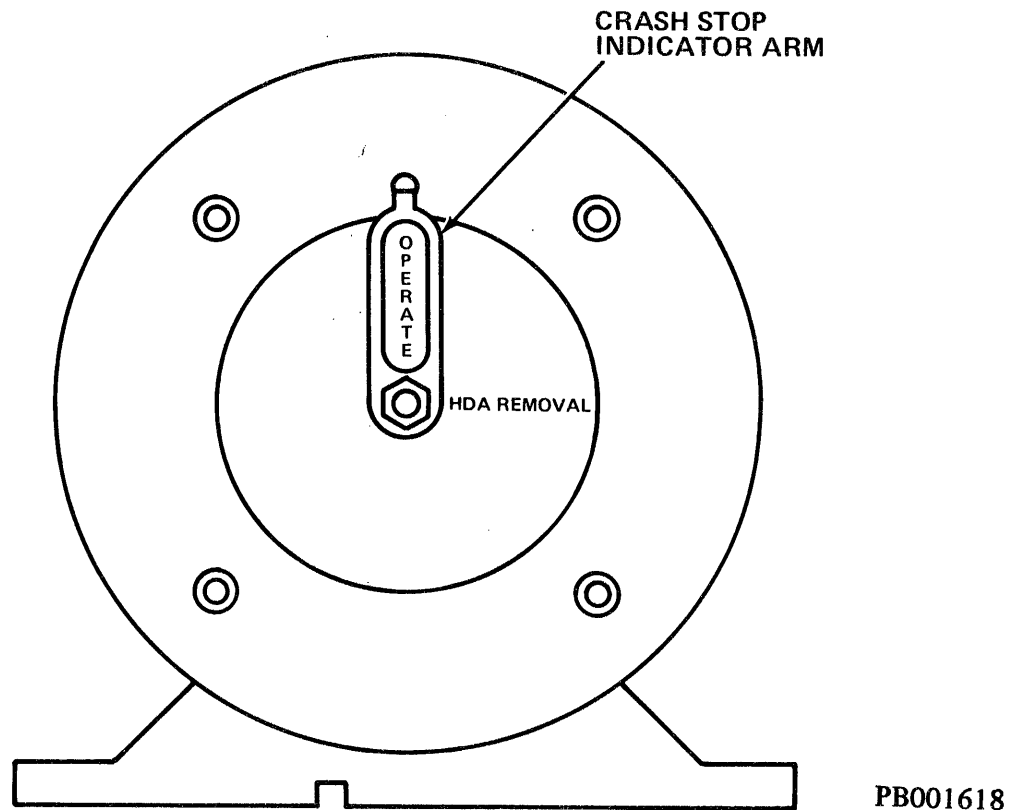
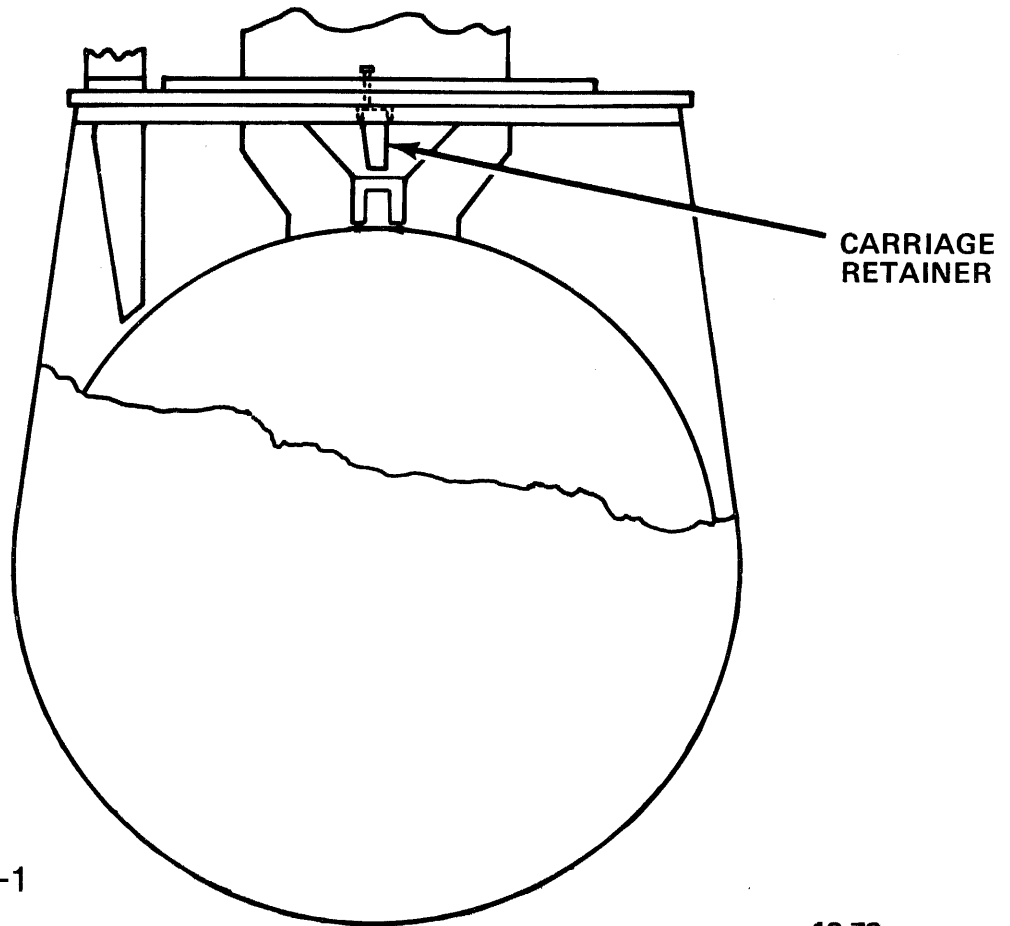

Figure 2-11-C Crash Stop Indicator Arm

- i. Remove EMA Exhaust Filter.
- ii. Loosen crash stop retaining nut.
- iii. Rotate crash stop clockwise no more than 3 to 5 degrees. Carriage should be free to move toward spindle. If carriage does not move, recheck voltage source leads.
- iv. Once carriage moves, temporarily disconnect one lead from voltage source.
- v. Continue to rotate crash stop indicator arm clockwise until it completes full turn to original position.
- vi. Re-tighten crash stop retaining nut.
- vii. Replace EMA Exhaust Filter.
- viii. Reconnect VOM battery lead. Carriage should now move toward spindle and come to rest against inner crash stop (stack spinning).

See Figure 2-11-D.





PB001636-1

12-79

Figure 2-11-D HDA Carriage Retainer

15. Note position of the topmost head/arm assembly relative to tip of carriage retainer in order to gauge carriage movement.
  - a. Remove VOM battery and visually confirm that carriage travels back toward EMA in a smooth even motion.
  - b. Reverse leads across VOM battery and visually confirm that carriage fully retracts to outer crash stop.
16. Place START/STOP switch in STOP.
17. When stack stops spinning, set CB1 OFF and place the FE local/normal switch to normal.
18. Disconnect VOM battery and connect EMA leads to backpanel at E1 and E2.
19. Set CB2 ON.
20. Set CB1 ON.
21. Place START/STOP switch in START. After appropriate delay for motor stop-start and normal purge cycle, FE Panel Program Code Display shows 02, 03, 04 and 05 in rapid succession followed by 06, On Track Monitor.

## **2.12 POWER HEAD LOAD**

Power head load places drive heads on cylinder 0.

When START/STOP switch is placed in START position, the microprogram jumps from Initialization Routine to Sequencing Routine to control and monitor the RP07 while stack is coming up to speed and during tachometer calibration.

Calibration is integral to the head load process. The drive completes calibration in four seconds, setting up a 30-track seek and measuring time to seek completion. If calibration is unsuccessful, carriage speed is modified for second attempt.

After successful tachometer calibration, Sequencing Routine restores drive to cylinder 0. The program allows up to 30 attempts to locate track 0 before posting an error.

## **2.13 SUBSYSTEM SEQUENCING CHECKS**

Once the FE has verified head load on each drive, a sequence check on ALL drives insures that no two drives power up simultaneously.

The following steps are performed on ALL drives in a line to insure correct line sequencing:

1. Turn off main source of AC power. Allow stacks to stop spinning.
2. Place START/STOP switch in all drives in START position (up).
3. Set CB1 ON (all drives).
4. Place FE Mode switch in NORMAL position.
5. Place ON LINE switch in ONLINE position (up).
6. Turn ON main source of AC power.
7. Verify that stack spins on each drive, one at a time.

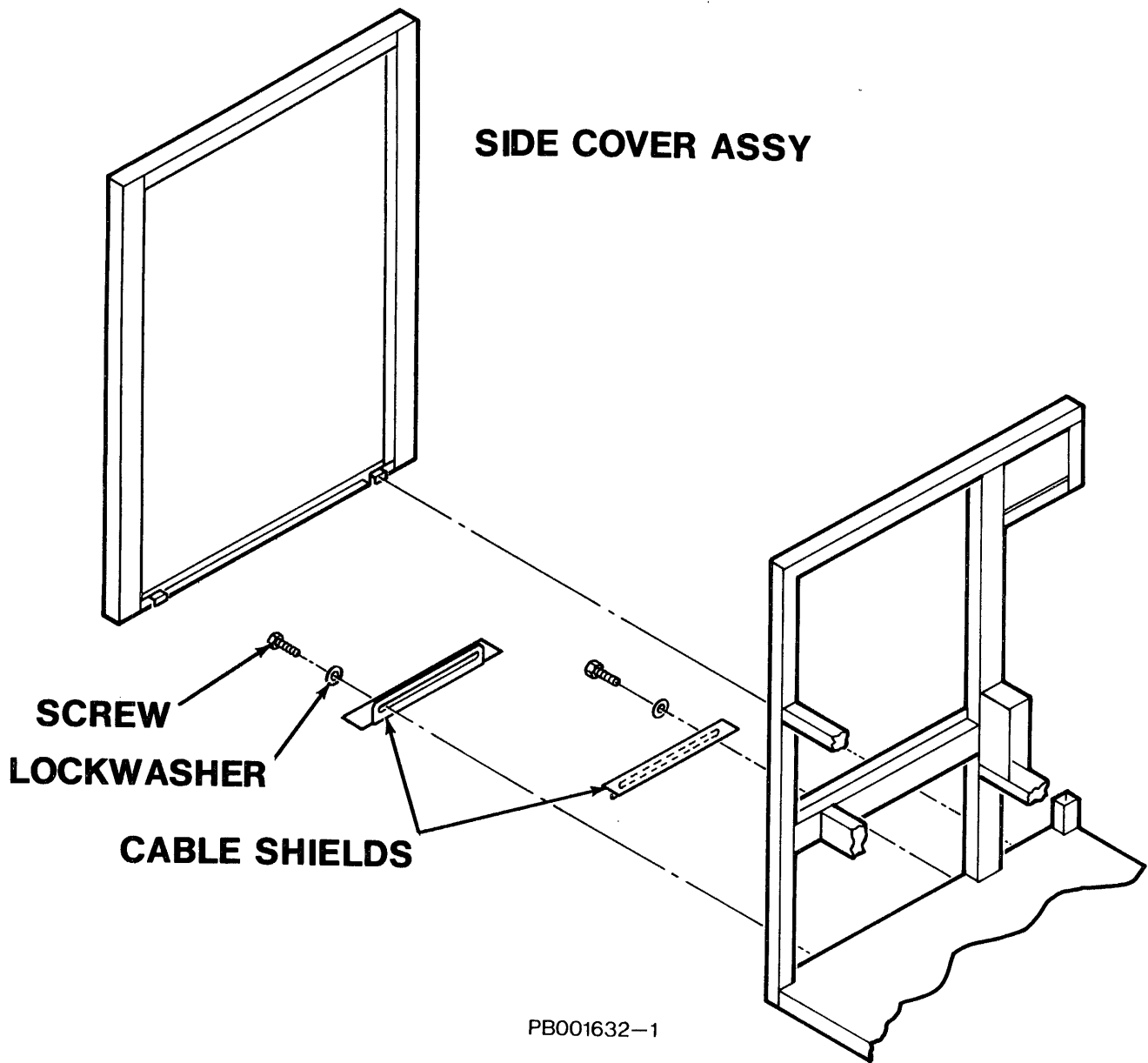

Figure 2-13-A Cable Shields

The following steps complete RP07 subsystem checks:

1. Install cable shield cover plates on end drives. (See Figure 2-13-A.) Adjust for MINIMUM opening. Shields must be installed to prevent overheating.
2. Check to insure that no installation tools have been left in a drive.

**NOTE**

Side covers are not used between drives bolted together; only exposed sides are covered.

3. At the front of each drive install the EMA cover shield. Slide the lower portion of the shield over the lower horizontal frame member and lift up until the upper edge of the shield containing the retainer clip latches with the upper horizontal frame member. See Figure 2-13-B.
4. Install the end-drive side covers.

**NOTE**

All drive covers must be in place during operation to insure adequate temperature control.

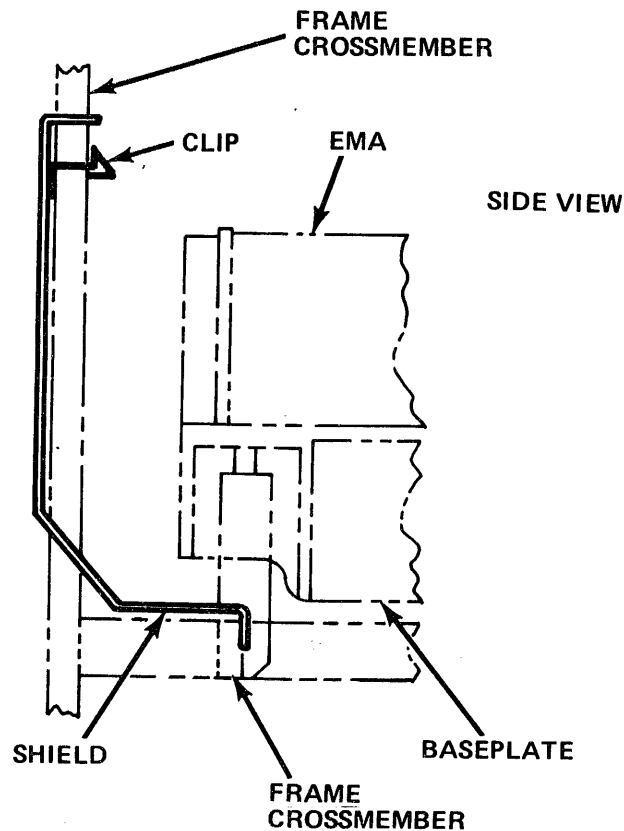

PB001873-2

Figure 2-13-B EMA Cover Shield Installation

5. Install front and rear covers.
6. Store manuals and spare parts in a safe, easily accessible location.
7. Report installation and any problems on appropriate forms.

After above steps have been completed, FE should run all applicable exercise, utility and Power On Start diagnostic routines - NO ERRORS allowed. See Chapter 3 of the Service Manual. Should the FE wish to read the microcode level resident in the drive, routine 17 (Read RAM) with a parameter of 71 (8080 microcode level) or 72 (2901 microcode level) will provide that information.

## **2.14 FIELD ACCEPTANCE TESTS**

Refer to applicable systems documentation.

## **2.15 MOVING THE DRIVE AFTER INSTALLATION**

This section provides procedures for moving RP07 short or long distances:

- Preparing
- Moving
- Repacking

### **CAUTION**

To prevent SEVERE DAMAGE to HDA, moving procedures must be followed.

#### **2.15.1 Moving**

Always perform the following steps - even to move RP07 a short distance.

1. Obtain permission to interrupt data processing operations at all drives in power and/or signal string.
2. Insure that all drives in power and/or signal string are OFFLINE and powered down.
3. Place START/STOP switch to STOP; when stack stops spinning, set CB1 OFF.
4. Set CB2 OFF
5. Remove EMA shield cover by inserting a narrow pointed object (narrow blade screwdriver) into the hole in the upper center of the shield. By applying pressure, the retainer clip will release. Pull down on the shield and slide it out.
6. Set CB1 ON. Place START/STOP switch to START.
7. Connect one of the following devices across E1 and E2 terminals on backpanel to drive the heads toward the EMA magnet:
  - a. A 1.5 - 3V battery powered VOM (using X1 ohm scale),
  - b. A 1.5V battery.

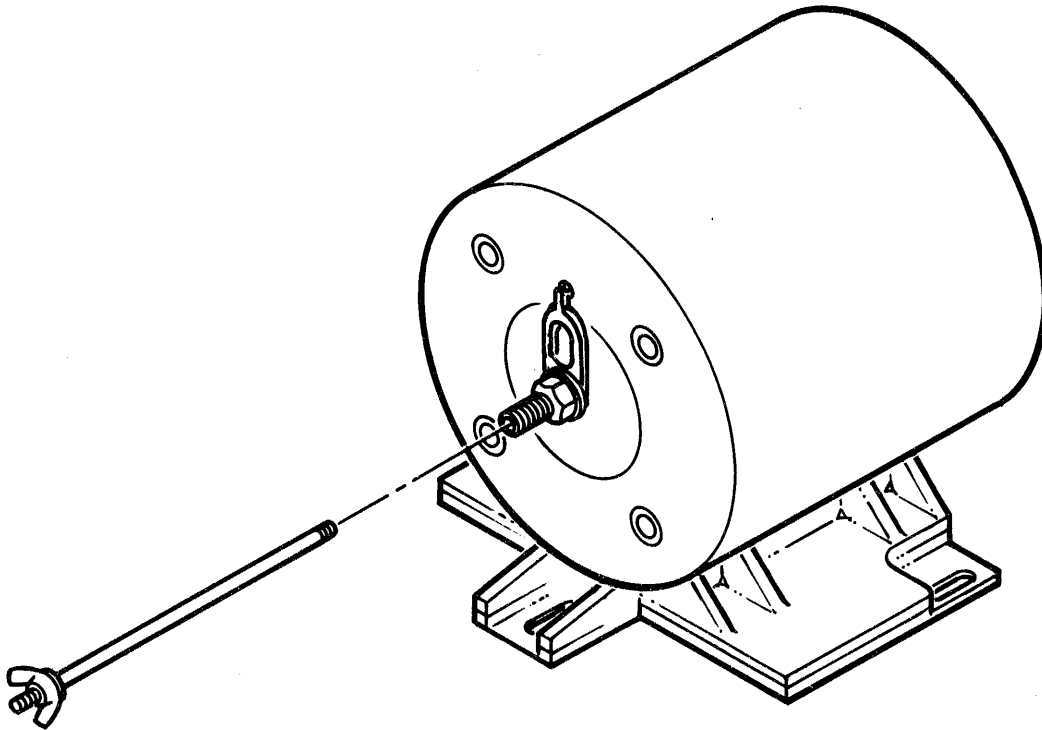

PB001618-1

1-80

Figure 2-15 EMA and Shipping Rod

8. Remove shipping rod from its storage clip on baseplate casting.
9. Back off wingnut sufficiently to allow shipping rod to reach coil. See Figure 2-15.

**CAUTION**

**DO NOT TIGHTEN SHIPPING ROD.**

10. Carefully insert short threaded end of shipping rod through hole in crash stop shaft and turn it clockwise 3 to 5 turns. **DO NOT TIGHTEN.**
11. Turn wingnut clockwise until wingnut, lockwasher, flatwasher, and end of crash stop are all in contact. Tighten one and one-half (1½) turns, **NO MORE.**
12. Disconnect voltage source from E1 and E2 terminals.
13. Place START/STOP switch to STOP.
14. Set CBI OFF. Remove main source of AC power.

### **WARNING**

CBI must be OFF on all drives (in string) and main source of AC power removed to avoid personal injury when removing AC cables in step 15.

15. Remove AC power cables from A2J1 and A2J2 at the drive being moved.
16. Remove Massbus cable from immediately adjacent drive connectors at cable-tray (A9) backplate.
17. Remove the DC ground cable. Reinstall the green logic safety ground.
18. Remove bolts holding drive frames together at upper front and lower rear.
19. Lower drive to its casters by raising jackstands.
20. Remove drive from system.
21. After relocation, perform entire check out procedure.

#### **2.15.2 Repacking the Drive**

##### Short Distance Moving

To move an RP07 ACROSS A ROOM or to ANOTHER AREA in the same building, it is not necessary to cover or crate the drive. Perform steps 1 - 21 of Subsection 2.15.1 of this manual.

##### Long Distance Moving

To move the drive to ANOTHER BUILDING or for SHIPPING, the following procedure is required:

1. Perform steps 1 - 20 of Subsection 2.15.1 of this manual.
2. Replace plastic cover on the drive.
3. Recrate drive.

## CHAPTER 3

### MICRODIAGNOSTICS

#### 3.1 INTRODUCTION

This chapter covers the use of the microdiagnostic routines resident in the RP07. The chapter is divided into the following subsections:

- FE Panel
- Preparing the drive for microdiagnostics
- Entering microdiagnostics from the FE Panel
- Microdiagnostic routine types
- Summary of microdiagnostic routines
- Microdiagnostic routine flowcharts

#### 3.2 FE PANEL

The Operator Control Panel Assembly (A1A20) is attached to the top of the Electronics Library (see Figure 3-2-A). The Control Panel Assembly has two components: the Operator's Control Panel and the Field Engineer's Control Panel. The Field Engineer's (FE) Control Panel, Figure 3-2-B, accessible only when the top cover of the drive is opened, is used by the FE to monitor and perform microdiagnostic routines in the drive. Through an interface with the microprocessor, the FE Panel on the RP07 is used for running three types of routines: Exerciser, Utility, and Diagnostic. These routines will indicate whether or not the drive is operating properly.

##### 3.2.1 FE Panel Makeup

The FE Panel has five major components.

**3.2.1.1 Hexadecimal Keyboard** - The Hexadecimal Keyboard is used by the FE to:

- Initiate a particular routine by keying in the routine call number
- Reply to prompts from the Data Display when such requests are made by the routine

The Hex Keyboard is activated only when the FE Panel Mode switch is in the FE Local Mode. Entries into the keyboard appear in the Data Display. They are accepted by the drive only when the ENTER/STEP switch is depressed.

**3.2.1.2 LED Displays** - The LED Displays provide the visual communications path between the drive and the FE. These displays, located above the keyboard, are arranged in two groups: the left display (PROGRAM CODE) and the right display (DATA). Each of these display groups displays one byte of information.



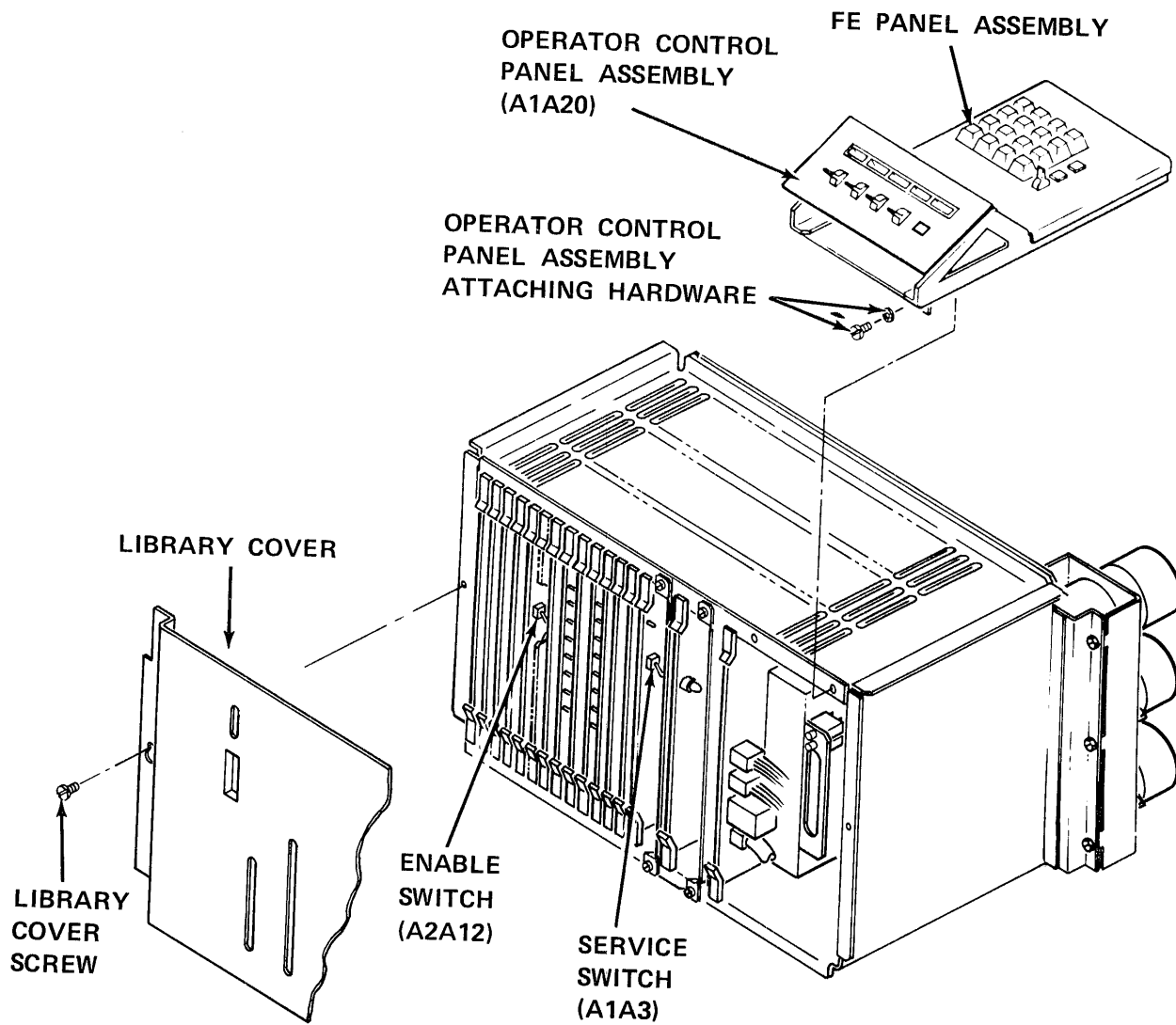

PB001626-1  
12/79

Figure 3-2-A Operator Control Panel Assembly

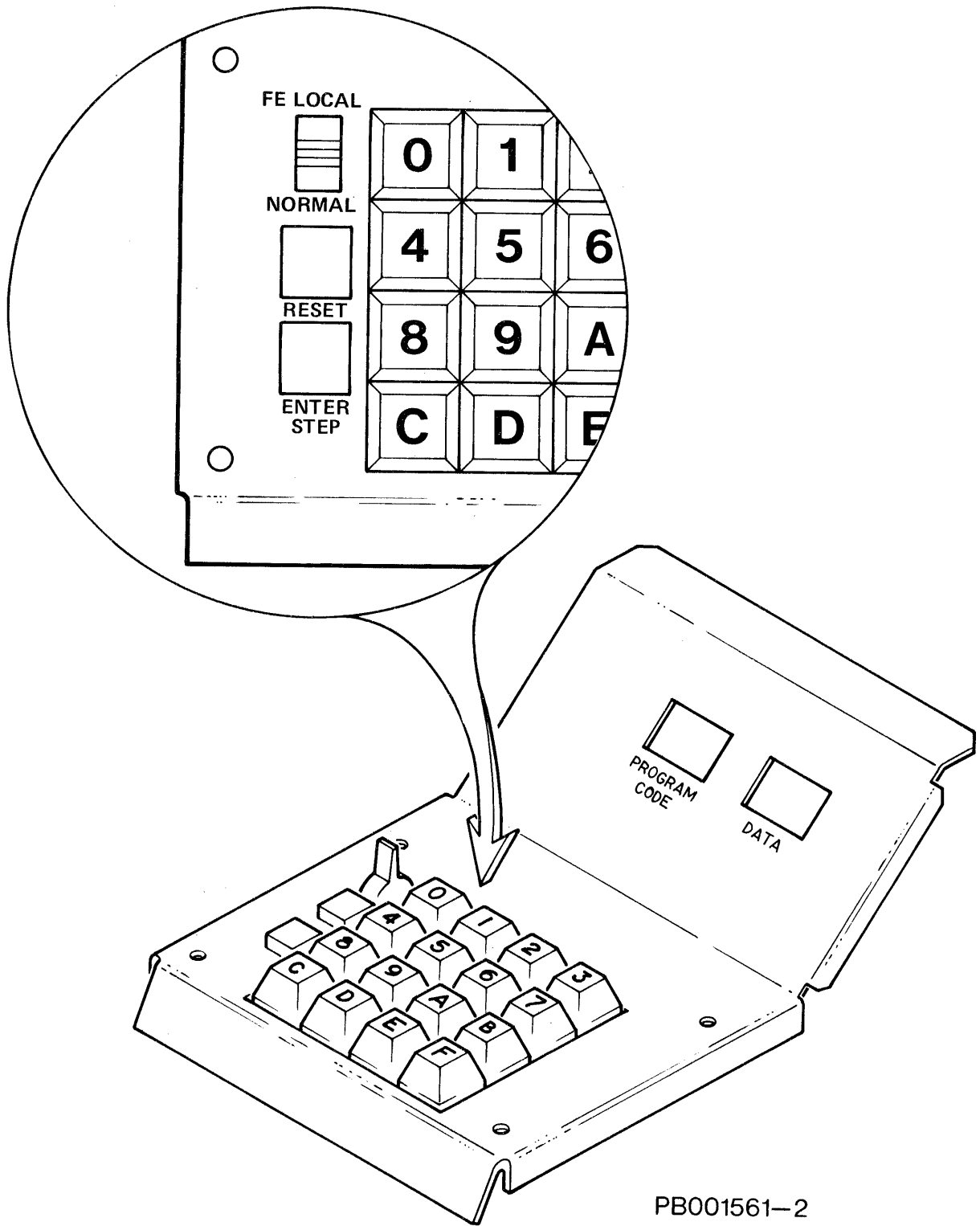

PB001561-2

Figure 3-2-B FE Control Panel

- Program Code - The Program Code reads out the number of the routine being run and verification of its successful completion.
- Data Display - the Data Display reads out the parameter entries from the keyboard, prompts from the microcode, and the error codes of routines that have failed.

**3.2.1.3 Mode Switch** - The FE Panel Mode switch is a two-position toggle switch allowing the FE to select one of two modes of operation:

- Normal (Functional) - The drive executes instructions via the Massbus. No manual functions can be executed in this mode.
- FE Local (Manual Intervention by FE) - Input through the FE Panel is enabled, however routines cannot be executed until the password "FE" is keyed and entered to unlock the interface between the FE Panel Keyboard and the microprocessor.

**3.2.1.4 Reset Switch** - The Reset switch, when depressed, will stop a routine being executed only when the routine performs a switch sample. This means that the Reset switch must remain depressed until the microdiagnostic routine enters the switch handler subroutine. The Reset switch is only effective in FE Local Mode.

**3.2.1.5 ENTER/STEP Switch** - The ENTER/STEP switch is used to enter previously keyed information into the microprocessor system.

- When depressed after a two digit keyboard entry:
  1. Will enter a routine call number
  2. Will enter requested (prompted) parameters into the routine
- When depressed during the Read RAM routine (routine 17), will advance the memory address by 1.
- When depressed after the single execution parameter has been set, will cause the routine to be executed once for each depression of the switch.

### **3.3 PREPARING DRIVE FOR DIAGNOSTICS**

Diagnostics can be executed from either the host processor or from the FE Control Panel. Subsections 3.3.1 and 3.3.2 provide the procedures for preparing the RP07 for diagnostics.

#### **3.3.1 Diagnostics From Host Processor**

To run diagnostics on a drive from a host processor the drive must be powered up, online, and accessed through the correct port. The following procedure will accomplish this:

1. With the Operator START/STOP Switch in the STOP position, place CB1, CB2, CB3 and the SERVICE Switch ON in that order.
2. Place the FE Mode switch in the NORMAL position.
3. Place the Write Protect switch OFF unless specific instructions with the diagnostic test indicate otherwise.

4. Place Access A, A/B, B switch in appropriate state to access the host processor.
5. Place ONLINE/OFFLINE to ONLINE.

**NOTE**

At this point, with the stack stopped, many of the diagnostic tests can be run. consult Table 3-5-1-A specific requirements for each diagnostic routine.

6. Place START/STOP Switch in the START position.

**3.3.2 Diagnostics From FE Panel**

The FE Panel on the RP07 Disk drive is used for running three types of routines on an offline drive: Exerciser, Utility, and Diagnostic routines. These routines indicate whether or not the drive is operating properly. Below are maintenance procedures for powering up the drive and/or putting it offline, and general procedures for running each type of routine.

**3.3.2.1 Powering Up and/or Placing the Drive Offline** - Before most of the diagnostic can be run, the designated drive must be powered up to a READY state (if it is not powered up), or placed offline if it is powered up and online.

1. To power up the drive, place the MODE SELECT switch on the FE Panel to NORMAL.
2. With the Operator Panel START/STOP Switch in the STOP position, set CB1, CB2, CB3 and the SERVICE switch to ON (if not already on), in that order. The microprocessor will begin running the Initialization routine, which will be indicated in the PROGRAM CODE display as follows:

	Program Code	Data	
A. Initialization	01	XX	Check A7 LEDs bits 0 - 7 for error display.
B. Initialization (Purge Loop)	03	XX	

At this point, switch to FE LOCAL permits most of the utility and diagnostic routines to be run.

3. To execute routines requiring "Stack at Speed", switch the START/STOP Switch to START. This initiates the following sequence of events:
- |                                  |    |    |  |
|----------------------------------|----|----|--|
| C. Power Sequence<br>(Wait Loop) | 04 | XX |  |
|----------------------------------|----|----|--|

	<b>Program Code</b>	<b>Data</b>	
D. Power Sequence	05	XX	Continue to ignore data display. Error code will appear on A1A7 PCA LEDs.
E. Recal State	07	XX	
F. Seek state	08		
G. On Track Monitor	06	XX	

**NOTE**

Steps E and F represent a tachometer calibration cycle. A number of these may occur under normal operation.

4. Assuming no failure has occurred up to this point, as soon as the "06" appears, the drive is ready for diagnostic activity. Place the Mode Select switch in FE LOCAL Mode before beginning diagnostics. The data display will now show:

<b>Program Code</b>	<b>Data</b>
CE	00

**NOTE**

From this point on and until the Mode switch is changed, any error codes generated will appear in the data display.

Do not confuse prompt messages and entered data with error codes. Also it is good practice to interrogate the drive error log at this point to determine the type and, in some instances, the quantity of errors which have accumulated since the last initialization occurred. See Diagnostic Routine 17 for details.

### 3.4 ENTERING ROUTINES

In order to enter microdiagnostic routines, the service person must "unlock" the FE Operator Panel. To do this the FE will key in the password "FE" on the keyboard and depress the ENTER/STEP switch. "FE" will appear in the program display indicating the keyboard is unlocked.

#### 3.4.1 Loading A Sample Routine

The following procedure is provided to the FEs to enable them to successfully load and execute microdiagnostic routines from the FE Panel. Using routine 10 (Seek-Seek) as an example, the FE wants to set up the following conditions:

- Seek between cylinders 3 and 297
- Delay approximately 2 msec between seeks
- Stop the routine on any Seek Incomplete error

The FE will perform the following steps:

	Program Code	Data Display	
	FE	00	FE keyboard "unlocked"
1.	Key 10 (routine number) into FE keyboard.		
	FE	10	
2.	Depress ENTER/STEP switch.		
	10	01	01 = Prompt for first of six required parameters
3.	Key in 00.		
	10	00	First cylinder high order byte = 00 First cylinder value = 3
4.	Depress ENTER/STEP switch.		
	10	02	02 = prompt for second parameter
5.	Key in 03		
	10	03	First cylinder low order byte $03_H = 03_{10} \quad 0 + 3 = 3$
6.	Depress ENTER/STEP switch		
	10	03	03 = prompt for third parameter
7.	Key in 01		
	10	01	Second cylinder high order byte $01_H = 256_{10}$
8.	Depress ENTER/STEP switch		
	10	04	04 = prompt for fourth parameter
9.	Key in 29		
	10	29	Second cylinder low order byte $29_H = 41_{10} \quad 256 + 41 = 297$

- |     |         |            |               |  |
|-----|---------|------------|---------------|--|
| 10. | Depress | ENTER/STEP | switch        |  |
|     | 10      | 05         |               | 05 = prompt for fifth parameter  |
| 11. | Key in  | 10         |               |  |
|     | 10      | 10         |               | Delay between seeks  |
|     |         |            |               | $10_H = 16_{10} \quad 128 \text{ microsec} \times 16 = 2.048 \text{ msec}$ |
| 12. | Depress | ENTER/STEP | switch        |  |
|     | 10      | 06         |               | 06 = prompt for last parameter   |
| 13. | Key in  | any value  | from 00 to FE |  |
|     | 10      | F0         |               | Halt on Seek Incomplete error  |
| 14. | Depress | ENTER/STEP | switch        |  |

When the last parameter has been entered no further prompt messages will appear. Instead the Program Display will display "C0" indicating the program is running. The Data Display will show "00" unless a fault occurs in which case an error code will be displayed. When the routine is completed, if in single cycle mode, the Program Display will show a "CF".

### 3.4.2 Errors in Loading

If there is a problem in loading a routine or a parameter the drive will respond with an "FE" in the Program Display and an "EE" in the Data Display. The routine will have to be completely reloaded. In order to reload the routine, the FE panel must again be unlocked by keying then entering "FE".

### 3.5 MICRODIAGNOSTIC ROUTINE TYPES

RP07 microdiagnostics are internally resident routines that exercise and test drive functions allowing the Field Engineer (FE) to diagnose problems within the drive, and to verify the fix before returning the drive to the customer. These routines can be divided into three categories:

- Diagnostic Routines - These routines are used to test the hardware pieces in the drive. An error code will be posted if a fault is encountered.
- Utility Routines - Used to help service personnel examine drive conditions or to simulate drive conditions. An error will be posted if a fault is encountered.
- Exercise Routines - Used to simulate the actual functional operation of the drive, such as Seek and Recal. Exercise routines are not available to the host processor system.

Many of these routines are run by the 8080 microprocessor during the initialization phase of the drive power up sequence, before the disk stack starts spinning and the servo is activated. Any errors detected at this time will inhibit drive start-up and will be logged in an Internal Error Log which can be accessed either by the host processor or via the FE

Control Panel. In addition, errors detected later, when the drive is powered up, will be noted in the same error log.

### 3.5.1 Summary of Microdiagnostic Routines

Table 3-5-1-A contains a summary of the microdiagnostic routines currently available to the FE. Table 3-5-1-B gives the number of parameters required for each routine. Following these two tables is a summary of each of the microdiagnostic routines.

#### NOTE

RTN 21 can only be used after RTN 20 has been performed.

Table 3-5-1-A Summary of Microdiagnostic Routines

<u>RTN ID (HEX)</u>	<u>RTN NAME</u>	<u>STACK AT SPEED</u>	<u>AVAILABLE TO HOST</u>	<u>RUN AT INITIAL</u>	<u>RTN TYPE</u>
10	Seek-Seek	Yes	No	No	EX
11	Incremental Seek	Yes	No	No	EX
12	Random Seek	Yes	No	No	EX
13	Recal-Recal	Yes	No	No	EX
14	Tachometer Diagnostics	Yes	Yes	Yes	DI
15	Indicator Test Routine	X	No	No	EX
16	FE Control Panel Test	X	No	Yes	EX
17	RAM Read	X	Yes	No	UT
18	PLO Unsafe	Yes	Yes	Yes	DI
19	EMA Driver Current Reporting	Yes	Yes	Yes	DI
1A	Index/Sector/LA Reg/Unsafe	Yes	Yes	Yes	DI
1B	Read/Write Safety Extended	Yes	Yes	Yes	DI
1C	SERDES Extended	Yes	Yes	Yes	DI
1D	Data Encode/Decode	Yes	Yes	Yes	DI
1E	Read Track Descriptor	Yes	Yes	No	DI
1F	Write Null	Yes	Yes	Yes	DI
20	Write/Read	Yes	Yes	Yes	UT
21	Read Data	Yes	Yes	No	DI
22	AM Test	Yes	Yes	Yes	DI
23	CROM Parity (DCL) Check	X	Yes	Yes	DI
24	PROM Check	X	Yes	Yes	DI
25	Register Check	X	No	Yes	DI
26	Interrupt Check	X	Yes	Yes	DI
27	CPU Unsafe	X	Yes	Yes	DI
28	Timer Test	X	Yes	Yes	DI
29	Bus Check	X	Yes	Yes	DI
2A	Analog C	X	Yes	Yes	DI
2B	A/D	X	Yes	Yes	DI
2C	A/D - D/A	X	Yes	Yes	DI
2D	Oscillator	X	Yes	Yes	DI
2E	Difference Counter	X	Yes	Yes	DI
2F	Linear Mode	X	Yes	Yes	DI
30	Cylinder Detector	X	Yes	Yes	DI
31	Position Channel	X	Yes	Yes	DI
32	Servo Amp	X	Yes	Yes	DI
33	Curve Generator	X	Yes	Yes	DI



Table 3-5-1-A Summary of Microdiagnostic Routines (Continued)

<u>RTN ID (HEX)</u>	<u>RTN NAME</u>	<u>STACK AT SPEED</u>	<u>AVAILABLE TO HOST</u>	<u>RUN AT INITIAL</u>	<u>RTN TYPE</u>
34	Comm/Maint Regs	X	Yes	Yes	DI
35	CROM Check Sum (DCL) Test	X	Yes	Yes	DI
36	DCL1	X	Yes	Yes	DI
37	DCL2	X	Yes	Yes	DI
38	I/O Wrap	X	Yes	Yes	DI
39	Full Check on J12	X	Yes	Yes	DI
3A	SERDES Wrap	X	Yes	Yes	DI
3B	R/W Basic	X	Yes	Yes	DI
3C	DCL Utility for Cntrl Sig	X	No	No	UT
3D	8080 Utility for Cntrl Sig	X	No	No	UT
3E	Pack Spin Up Utility	X	No	No	UT
3F	Pack Spin Down Utility	X	No	No	UT
40	CROM Read Utility	X	No	No	UT
41	Dummy				
42	Dummy				
43	Dummy				
44	Dummy				
45	Zero RAM Read	X	Yes	No	UT
46	Tachometer Calibration	Yes	Yes	Yes	UT
47	Test all Initialization Rtns	Yes	No	No	UT

**NOTE:** X = Don't Care  
 EX = Exercise  
 UT = Utility  
 DI = Diagnostic

Table 3-5-1-B Parameter Requirements

<u>RTN NAME</u>	<u>RTN ID (HEX)</u>	<u>NUMBER OF PARAMETERS</u>
Seek-Seek	10	6
Incremental Seek	11	3
Random Seek	12	2
Recal-Recal	13	2
Tachometer Diagnostics	14	1
Indicator Test Routine	15	0
FE Control Panel Test	16	0
RAM Read	17	1
PLO Unsafe	18	1
EMA Driver Current Reporting	19	1
Index/Sector/LA Reg/Unsafe	1A	1
Read/Write Safety Extended	1B	1
SERDES Extended	1C	1
Data Encode/Decode	1D	1
Read Track Descriptor	1E	2
Write Null	1F	2
Write/Read	20	2
Read Data	21	2
AM Test	22	2
CROM Parity (DCL) Check	23	1
PROM Check	24	1
Register Check	25	1
Interrupt Check	26	1
CPU Unsafe	27	1
Timer Test	28	1
Bus Check	29	1
Analog C	2A	1
A/D	2B	1
A/D - D/A	2C	1
Oscillator	2D	1
Difference Counter	2E	1
Linear Mode	2F	1
Cylinder Detector	30	1
Position Channel	31	1
Servo Amp	32	1
Curve Generator	33	1
Comm/Maint Regs	34	1
CROM Check Sum (DCL) Test	35	1
DCL1	36	1
DCL2	37	1
I/O Wrap	38	1
Full Check on J12	39	1
SERDES Wrap	3A	1
R/W Basic	3B	1
DCL Utility for Cntrl Sig	3C	1
8080 Utility for Cntrl Sig	3D	1
Pack Spin Up Utility	3E	1
Pack Spin Down Utility	3F	1

Table 3-5-1-B Parameter Requirements (Continued)

<u>RTN NAME</u>	<u>RTN ID (HEX)</u>	<u>NUMBER OF PARAMETERS</u>
CROM Read Utility	40	2
Zero RAM Read	45	1
Tachometer Calibration	46	1
Test all Initialization Routines	47	1

**ROUTINE ID (HEX):** 10

**ROUTINE NAME:** Seek-Seek

**ROUTINE DESCRIPTION:**

This exerciser routine causes the drive to perform alternate seeks between the two specified cylinders. Any Seek Incompletes will result in an error code being displayed in the Data Display on the FE Panel.

**PARAMETERS: 6**

<u>BYTE NUMBER</u>	<u>VALUE LIMIT</u>	<u>DESCRIPTION</u>
01	00,01,02	First cylinder high order byte.
02	00-FF,00-FF,00-77	First cylinder low order byte. Maximum value permitted depends on Byte 01. 0277 <sub>H</sub> = CYL 631.
03	00,01,02	Second cylinder high order byte.
04	00-FF, 00-FF, 00-77	Second cylinder low order byte. Maximum value permitted depends on Byte 03. 0277 <sub>H</sub> = CYL 631.
05	00-FE	Delay = (Value) X 128 microseconds. FE = 32.5 msec delay between seeks.
	FF	Single cycle.
06	00-FE	Halt on Seek Incomplete error. Resume routine execution by depressing the ENTER/STEP switch.
	FF	Ignore Halt on Error. Drive performs recal and resumes seeking without operator intervention.

**NOTE:**

This routine cannot be executed from the system.

**ROUTINE ID (HEX):** 11

**ROUTINE NAME:** Incremental Seek

**ROUTINE DESCRIPTION:**

This exerciser routine causes the drive to perform consecutive seeks to cylinders separated by the specified increment. Any Seek Incompletes will result in an error code being displayed in the Data Display of the FE Panel.

**PARAMETERS:** 3

<u>BYTE NUMBER</u>	<u>VALUE LIMIT</u>	<u>DESCRIPTION</u>
01	01-FF	Increment (in cylinders) 01 = 1 cylinder FF = 255 cylinders
02	01-FE	Delay = (Value) X 128 microseconds. FE = 32.5 msec between seeks.
	FF	Single cycle.
03	00-FE	Halt on Seek Incomplete Error. Resume routine execution by depressing the ENTER/STEP switch.
	FF	Ignore halt on error. Drive performs recal and resumes seeking without oper- ator intervention.

**NOTE:**

This routine cannot be executed from the system.

**ROUTINE ID (HEX):** 12

**ROUTINE NAME:** Random Seek

**ROUTINE DESCRIPTION:**

This exerciser routine causes the drive to perform seeks to random cylinders. Any Seek Incompletes will result in an error code being displayed in the Data Display of the FE Panel.

**PARAMETERS: 2**

<u>BYTE NUMBER</u>	<u>VALUE LIMIT</u>	<u>DESCRIPTION</u>
01	00-FE	Delay = (Value) X 128 microseconds.
	FF	Single cycle.
02	00-FE	Halt on Seek Incomplete Error. Resume Routine execution by depressing the ENTER/STEP switch.
	FF	Ignore halt on error. Drive performs recal and resumes seeking without operator intervention.

**NOTE**

This routine cannot be executed from the system.

**ROUTINE ID (HEX):** 13

**ROUTINE NAME:** Recal-Recal

**ROUTINE DESCRIPTION**

This exerciser routine causes the drive to perform successive recals. Any Seek Incompletes will result in an error code being displayed in the Data Display of the FE Panel.

**PARAMETERS: 2**

BYTE NUMBER	VALUE LIMIT	DESCRIPTION
01	00-FE	Delay = (Value) X 128 microseconds.
	FF	Single cycle.
02	00-FE	Halt on error option. Resume routine execution by depressing the Enter/Step switch.
	FF	Drive continues doing recals without operator intervention.

**NOTE:**This routine cannot be executed from the system.

**ROUTINE ID (HEX):** 14

**ROUTINE NAME:** Tachometer Diagnostics

**ROUTINE DESCRIPTION:**

This diagnostic routine tests the Tach circuitry by sampling the Tach Out signal with the A/D circuitry under various conditions.

**PARAMETERS: 1**

BYTE NUMBER	VALUE LIMIT	DESCRIPTION
01	00-FE	Delay = (Value) X 128 microseconds.
	FF	Single cycle.

**ROUTINE ID (HEX):** 15

**ROUTINE NAME:** Indicator Test

**ROUTINE DESCRIPTION:**

This exerciser routine is used to test the indicators and switches on the Operator Panel and the FE Panel as well as the LEDs on the A1A7 and A1A9 PCAs. The stack need not be spinning. Keying in the routine number and depressing the ENTER/STEP switch will start the routine execution.

**PARAMETERS:** None

**NOTE:**

This routine cannot be executed from the system.

**ROUTINE ID (HEX):** 16

**ROUTINE NAME:** FE Control Panel Test

**ROUTINE DESCRIPTION:**

This exerciser routine is for checking the Front Panel switches, lamps and Data Display. This routine is executed during Drive Sequencing. Keying in the routine number and depressing the ENTER/STEP switch will start the routine execution.

**PARAMETERS:** None

**NOTE:**

This routine cannot be executed from the system.

**ROUTINE ID (HEX):** 17

**ROUTINE NAME:** Read RAM

**ROUTINE DESCRIPTION:**

This utility routine will read data from RAM. In FE Local Mode the routine takes one parameter which is used as the low address of the RAM space. This low order byte of RAM address will be displayed in the Program Display and the data at that address in the Error Display. The program will automatically increment through RAM every time the ENTER/STEP switch is depressed. In the ONLINE mode the routine will only read the target RAM location. Attached is a table explaining a few of the RAM location contents.

**PARAMETERS: 1**

<b>BYTE NUMBER</b>	<b>VALUE LIMIT</b>	<b>DESCRIPTION</b>
01	00-97	Low order byte of RAM address (18XX) 1800-1897

<b>MEMORY LOCATION</b>	<b>NUMBER OF ERRORS</b>	<b>DESCRIPTION OF CONTENTS</b>
------------------------	-------------------------	--------------------------------

32	XX	Seek to long errors
33	XX	Seek overshoot errors
34	XX	Soft seek overshoot errors
35	XX	Seek incomplete errors
36	XX	Number of Index errors
37	XX	Number of PLO unsafes
38	XX	Most recent error code encountered

The next 20 locations record the error codes that have been encountered and the number of times they occurred

39		Error Code
3A		Number of times this error code occurred

through

4B		Error Code
4C		Number of times this error code occurred
71		8080 microcode revision level
72		2901 microcode revision level



**ROUTINE ID (HEX):** 18

**ROUTINE NAME:** PLO Unsafe

**ROUTINE DESCRIPTION:**

This routine tests the unsafe circuitry and the index-timing. The unsafe check is accomplished by simulating an unsafe condition and then testing to be sure that an unsafe has occurred. Index timing is tested by measuring the time interval between index pulses and then testing to see if the time interval is within 3 percent of the specified limit.

**PARAMETERS: 1**

BYTE NUMBER	VALUE LIMIT	DESCRIPTION
01	00-FE	Delay = (Value) X 128 microseconds.
	FF	Single cycle.

**NOTES:**

If an error results, then the pack is not up to speed, or a fault exists with the PLO Unsafe or the index timing circuits.

**ROUTINE ID (HEX):** 19

**ROUTINE NAME:** EMA Current Driver Reporting

**ROUTINE DESCRIPTION:**

This routine checks the operation of the EMA Current Sampling circuit. It is checked by actuating the EMA with a known value and then sampling the current. The value is compared to the expected window to verify proper operation.

**PARAMETERS: 1**

BYTE NUMBER	VALUE LIMIT	DESCRIPTION
01	00-FE	Delay = (Value) X 128 microseconds.
	FF	Single cycle.

**NOTES:**

An error in this routine will indicate that the current sample circuits are not operating properly or CB2 is turned off. THIS ROUTINE ALSO CALIBRATES THE EMA CURRENT OFFSET TO 0.

**ROUTINE ID (HEX):** 1A

**ROUTINE NAME:** Index/Sector/LA Reg/Unsafe

**ROUTINE DESCRIPTION:**

This routine is used to check the number of sectors between two index pulses.

**PARAMETERS: 1**

BYTE NUMBER	VALUE LIMIT	DESCRIPTION
01	00-FE	Delay = (Value) X 128 microseconds.
	FF	Single cycle.

**ROUTINE ID (HEX):** 1B

**ROUTINE NAME:** Read/Write Safety Extended Diagnostic

**ROUTINE DESCRIPTION:**

This test is designed to position the heads over the Guard Band and call the extended R/W Safety Diagnostic in the DCL mode.

**PARAMETERS: 1**

BYTE NUMBER	VALUE LIMIT	DESCRIPTION
01	00-FD	Delay = (Value) X 128 microseconds.
	FE	Stop on error
	FF	Single cycle

**ROUTINE ID (HEX):** 1C

**ROUTINE NAME:** SERDES Extended Test

**ROUTINE DESCRIPTION:**

This test is designed to execute the extended SERDES check in the DCL mode.

**PARAMETERS: 1**

<b>BYTE NUMBER</b>	<b>VALUE LIMIT</b>	<b>DESCRIPTION</b>
01	00-FD	Delay = (Value) X 128 microseconds.
	FE	Stop on error
	FF	Single cycle

**ROUTINE ID (HEX):** 1D

**ROUTINE NAME:** Data Encode/Decode Test

**ROUTINE DESCRIPTION:**

This routine will invoke the DCL Data Encode/Decode Diagnostic.

**PARAMETERS: 1**

<b>BYTE NUMBER</b>	<b>VALUE LIMIT</b>	<b>DESCRIPTION</b>
01	00-FD	Delay = (Value) X 128 microseconds.
	FE	Stop on error
	FF	Single cycle

**ROUTINE ID (HEX):** 1E

**ROUTINE NAME:** FE Read Track Descriptor

**ROUTINE DESCRIPTION:**

This routine will recal, then seek to the FE cylinder and read the Track Descriptor at the selected head.

**PARAMETERS: 2**

BYTE NUMBER	VALUE LIMIT	DESCRIPTION
01	00-1F	Desired head number
	20	Sequence through all heads
02	00-FD	Delay = (Value) X 128 microseconds.
	FE	Stop on error
	FF	Single cycle

**ROUTINE ID (HEX):** 1F

**ROUTINE NAME:** FE Write Null Record Test

**ROUTINE DESCRIPTION:**

This routine will recal, then seek to the FE cylinder and read the Track Descriptor, write a null record, and then read it back.

**PARAMETERS: 2**

BYTE NUMBER	VALUE LIMIT	DESCRIPTION
01	00-1F	Desired head number
	20	Sequence through all heads
02	00-FD	Delay = (Value) X 128 microseconds.
	FE	Stop on error
	FF	Single cycle

**ROUTINE ID (HEX):** 20

**ROUTINE NAME:** Write/Read

**ROUTINE DESCRIPTION:**

This routine will recal, then seek to the FE cylinder and write data. The routine will then read the data back.

**PARAMETERS: 2**

BYTE NUMBER	VALUE LIMIT	DESCRIPTION
01	00-1F	Desired head number
	20	Sequences through all heads
02	00-FD	Delay = (Value) X 128 microseconds.
	FE	Stop on error
	FF	Single cycle

**ROUTINE ID (HEX):** 21

**ROUTINE NAME:** Read Data

**ROUTINE DESCRIPTION:**

This routine will recal, then seek to the FE cylinder and read data.

**PARAMETERS: 2**

BYTE NUMBER	VALUE LIMIT	DESCRIPTION
01	00-1F	Desired head number
	20	Sequences through all heads
02	00-FD	Delay = (Value) X 128 microseconds.
	FE	Stop on error
	FF	Single cycle

**ROUTINE ID (HEX):** 22

**ROUTINE NAME:** AM Test

**ROUTINE DESCRIPTION:**

This routine will recal, then seek to the FE cylinder and perform the AM Write/Read Test.

**PARAMETERS: 2**

BYTE NUMBER	VALUE LIMIT	DESCRIPTION
01	00-1F	Desired head number
	20	Sequences through all heads
02	00-FD	Delay = (Value) X 128 microseconds.
	FE	Stop on error
	FF	Single cycle

**ROUTINE ID (HEX):** 23

**ROUTINE NAME:** CROM Parity (DCL) Check

**ROUTINE DESCRIPTION:**

This routine will check CROM's parity on all CROM locations from 0000 to FFFF, excluding 1F7-1FF which are reserved Checksum storages.

**PARAMETERS: 1**

BYTE NUMBER	VALUE LIMIT	DESCRIPTION
01	00-FD	Delay = (Value) X 128 microseconds.
	FE	Stop on error.
	FF	Single cycle.

**NOTES:**

The routine will set the error address at the display lamps on the FE Panel where the Program Display will have the high address and the Data Display will have the low address.

**ROUTINE ID (HEX):** 24

**ROUTINE NAME:** PROM Check

**ROUTINE DESCRIPTION:**

This routine is executed every time the drive is initialized. This routine checks all ROMs on PCA A1A7 (Servo Control).

**PARAMETERS: 1**

BYTE NUMBER	VALUE LIMIT	DESCRIPTION
01	00-FE	Delay = (Value) X 128 microseconds.
	FF	Single cycle.

**ROUTINE ID (HEX):** 25

**ROUTINE NAME:** Register Check

**ROUTINE DESCRIPTION:**

This routine checks all the input and output ports on PCA A1A7 (Servo Control). It is executed every time the drive is initialized.

**PARAMETERS: 1**

BYTE NUMBER	VALUE LIMIT	DESCRIPTION
01	00-FE	Delay = (Value) X 128 microseconds.
	FF	Single cycle.

**NOTES:**

This routine cannot be executed from the system.

**ROUTINE ID (HEX):** 26

**ROUTINE NAME:** Interrupt Check

**ROUTINE DESCRIPTION:**

This routine checks the interrupt structure on PCA A1A7 (Servo Control). It is executed every time drive is initialized.

**PARAMETERS: 1**

<b>BYTE NUMBER</b>	<b>VALUE LIMIT</b>	<b>DESCRIPTION</b>
01	00-FE	Delay = (Value) X 128 microseconds.
	FF	Single cycle.

**ROUTINE ID (HEX):** 27

**ROUTINE NAME:** CPU Unsafe

**ROUTINE DESCRIPTION:**

This routine checks the functioning of the CPU Unsafe circuit. It is executed every time the drive is initialized.

**PARAMETERS: 1**

<b>BYTE NUMBER</b>	<b>VALUE LIMIT</b>	<b>DESCRIPTION</b>
01	00-FE	Delay = (Value) X 128 microseconds.
	FF	Single cycle.



**ROUTINE ID (HEX):** 28

**ROUTINE NAME:** Timer Test

**ROUTINE DESCRIPTION:**

This routine tests the 8253 timer on the A1A7 PCA and its associated circuitry. It is executed every time the drive is initialized.

**PARAMETERS: 1**

<b>BYTE NUMBER</b>	<b>VALUE LIMIT</b>	<b>DESCRIPTION</b>
01	00-FE	Delay = (Value) X 128 microseconds.
	FF	Single cycle.

**ROUTINE ID (HEX):** 29

**ROUTINE NAME:** Bus Check

**ROUTINE DESCRIPTION:**

This routine verifies that the Data Bus is working. It is executed every time the drive is initialized.

**PARAMETERS: 1**

<b>BYTE NUMBER</b>	<b>VALUE LIMIT</b>	<b>DESCRIPTION</b>
01	00-FE	Delay = (Value) X 128 microseconds.
	FF	Single cycle.

**ROUTINE ID (HEX):** 2A

**ROUTINE NAME:** Analog C

**ROUTINE DESCRIPTION:**

This routine checks the ANALOG C RAM by exercising it with rotating test patterns through RAM. It is executed every time the drive is initialized.

**PARAMETERS: 1**

<b>BYTE NUMBER</b>	<b>VALUE LIMIT</b>	<b>DESCRIPTION</b>
01	00-FE	Delay = (Value) X 128 microseconds.
	FF	Single cycle.

**ROUTINE ID (HEX):** 2B

**ROUTINE NAME:** A/D

**ROUTINE DESCRIPTION:**

This routine checks the limits of conversion of the A/D Converter. It also performs the zeroing of the A/D Converter. It is executed every time the drive is initialized.

**PARAMETERS: 1**

<b>BYTE NUMBER</b>	<b>VALUE LIMIT</b>	<b>DESCRIPTION</b>
01	00-FE	Delay = (Value) X 128 microseconds.
	FF	Single cycle.

**ROUTINE ID (HEX):** 2C

**ROUTINE NAME:** A/D - D/A

**ROUTINE DESCRIPTION:**

This routine checks the A/D and the D/A on PCA A1A4. It is executed every time the drive is initialized.

**PARAMETERS: 1**

<b>BYTE NUMBER</b>	<b>VALUE LIMIT</b>	<b>DESCRIPTION</b>
01	00-FE	Delay = (Value) X 128 microseconds.
	FF	Single cycle.

**ROUTINE ID (HEX):** 2D

**ROUTINE NAME:** Oscillator

**ROUTINE DESCRIPTION:**

This routine will automatically zero the Difference Position Offset. The Diff Pos Offset is checked to see if it is within specified limits and is referenced to the On Track signal. The AGC is checked for adequate gain.

**PARAMETERS: 1**

<b>BYTE NUMBER</b>	<b>VALUE LIMIT</b>	<b>DESCRIPTION</b>
01	00-FE	Delay = (Value) X 128 microseconds.
	FF	Single cycle.

**ROUTINE ID (HEX):** 2E

**ROUTINE NAME:** Difference Counter

**ROUTINE DESCRIPTION:**

This routine checks the Difference Counter for all possible bit combinations by rotating a test pattern through all possible combinations. It then checks the values in the Difference Counter.

**PARAMETERS: 1**

<b>BYTE NUMBER</b>	<b>VALUE LIMIT</b>	<b>DESCRIPTION</b>
01	00-FE	Delay = (Value) X 128 microseconds.
	FF	Single cycle.

**ROUTINE ID (HEX):** 2F

**ROUTINE NAME:** Linear Mode - Status Register Test

**ROUTINE DESCRIPTION:**

This routine checks the Linear Mode circuitry to verify that the Linear Mode bit can be set and reset.

**PARAMETERS: 1**

<b>BYTE NUMBER</b>	<b>VALUE LIMIT</b>	<b>DESCRIPTION</b>
01	00-FE	Delay = (Value) X 128 microseconds.
	FF	Single cycle.

**ROUTINE ID (HEX):** 30

**ROUTINE NAME:** Cylinder Detector

**ROUTINE DESCRIPTION:**

This routine checks the fine and coarse cylinder detectors. It is executed every time the drive is initialized.

**PARAMETERS: 1**

<b>BYTE NUMBER</b>	<b>VALUE LIMIT</b>	<b>DESCRIPTION</b>
01	00-FE	Delay = (Value) X 128 microseconds.
	FF	Single cycle.

**ROUTINE ID (HEX):** 31

**ROUTINE NAME:** Position Channel

**ROUTINE DESCRIPTION:**

This routine checks both the Differential Position and the Position channels. It is executed every time the drive is initialized.

**PARAMETERS: 1**

<b>BYTE NUMBER</b>	<b>VALUE LIMIT</b>	<b>DESCRIPTION</b>
01	00-FE	Delay = (Value) X 128 microseconds.
	FF	Single cycle.

**ROUTINE ID (HEX):** 32

**ROUTINE NAME:** Servo Amp

**ROUTINE DESCRIPTION:**

This routine verifies that the Servo Error Amp Offset is within the specified .5 Volt window. It is executed every time the drive is initialized.

**PARAMETERS: 1**

BYTE NUMBER	VALUE LIMIT	DESCRIPTION
01	00-FE	Delay = (Value) X 128 microseconds.
	FF	Single cycle.

**ROUTINE ID (HEX):** 33

**ROUTINE NAME:** Curve Generator

**ROUTINE DESCRIPTION:**

This routine tests the curve to be sure references are operating properly. It is executed every time the drive is initialized.

**PARAMETERS: 1**

BYTE NUMBER	VALUE LIMIT	DESCRIPTION
01	00-FE	Delay = (Value) X 128 microseconds.
	FF	Single cycle.

**ROUTINE ID (HEX):** 34

**ROUTINE NAME:** Comm/Maint Regs

**ROUTINE DESCRIPTION:**

This routine checks the functioning of the Command/Index/Sector PCA (A1A8). It is executed every time the drive is initialized.

**PARAMETERS: 1**

<b>BYTE NUMBER</b>	<b>VALUE LIMIT</b>	<b>DESCRIPTION</b>
01	00-FE	Delay = (Value) X 128 microseconds.
	FF	Single cycle.

**ROUTINE ID (HEX):** 35

**ROUTINE NAME:** CROM Check

**ROUTINE DESCRIPTION:**

This routine will verify the CROM Check Sums of DCL1 and DCL2.

**PARAMETERS: 1**

<b>BYTE NUMBER</b>	<b>VALUE LIMIT</b>	<b>DESCRIPTION</b>
01	00-FD	Delay = (Value) X 128 microseconds.
	FE	Stop on error.
	FF	Single cycle.

**ROUTINE ID (HEX):** 36

**ROUTINE NAME:** DCL1

**ROUTINE DESCRIPTION:**

This routine checks the functioning of the DCL1 PCA (A1A9). It is executed every time the drive is initialized.

**PARAMETERS: 1**

BYTE NUMBER	VALUE LIMIT	DESCRIPTION
01	00-FD	Delay = (Value) X 128 microseconds.
	FE	Stop on error.
	FF	Single cycle.

**ROUTINE ID (HEX):** 37

**ROUTINE NAME:** DCL2

**ROUTINE DESCRIPTION:**

This routine checks the function of the DCL2 PCA (A1A10). It is executed every time the drive is initialized.

**PARAMETERS: 1**

BYTE NUMBER	VALUE LIMIT	DESCRIPTION
01	00-FD	Delay = (Value) X 128 microseconds.
	FE	Stop on error.
	FF	Single cycle.



**ROUTINE ID (HEX):** 38

**ROUTINE NAME:** I/O Wrap

**ROUTINE DESCRIPTION:**

This routine checks the functioning of the Interface Control PCA (A1A12). It is executed every time the drive is initialized.

**PARAMETERS: 1**

BYTE NUMBER	VALUE LIMIT	DESCRIPTION
01	00-FD	Delay = (Value) X 128 microseconds.
	FE	Stop on error.
	FF	Single cycle.

**ROUTINE ID (HEX):** 39

**ROUTINE NAME:** Full Check on A1A12

**ROUTINE DESCRIPTION:**

This routine checks out the Interface Control PCA (A1A12). It can be called by the FE when in FE Local mode or from the host system thru the Diagnostic mode. Full and partial as referred to below describes how the test will exercise the parity checker on T Bus C interface lines. A full test uses the entire range of patterns. A partial test uses only one pattern. When in Online mode, full testing is forced.

**PARAMETERS: 1**

BYTE NUMBER	VALUE LIMIT	DESCRIPTION
01	00	Execute partial test
	01-FD	Execute the full test with the Delay defined by the parameter.
	FE	Execute the full test and stop if an error is detected.
	FF	Execute the full test in single cycle mode.

**ROUTINE ID (HEX):** 3A

**ROUTINE NAME:** SERDES Check

**ROUTINE DESCRIPTION:**

This routine checks the functioning of the SERDES PCA (A1A14).

**PARAMETERS: 1**

<b>BYTE NUMBER</b>	<b>VALUE LIMIT</b>	<b>DESCRIPTION</b>
01	00-FD	Delay = (Value) X 128 microseconds.
	FE	Stop on error.
	FF	Single cycle.

**ROUTINE ID (HEX):** 3B

**ROUTINE NAME:** Read/Write Safety Check

**ROUTINE DESCRIPTION:**

This routine checks the functioning of the Read/Write Safety PCA (A1A16).

**PARAMETERS: 1**

<b>BYTE NUMBER</b>	<b>VALUE LIMIT</b>	<b>DESCRIPTION</b>
01	00-FD	Delay = (Value) X 128 microseconds.
	FE	Stop on error.
	FF	Single cycle.

ROUTINE ID (HEX): 3C

ROUTINE NAME: DCL Utility for Control Signal

**ROUTINE DESCRIPTION:**

This test sets DCL in diagnostic mode.

**PARAMETERS: 1**

BYTE NUMBER	VALUE LIMIT	DESCRIPTION
01	00-FE	Delay = (Value) X 128 microseconds.
	FF	Single cycle.

ROUTINE ID (HEX): 3D

ROUTINE NAME: 8080 Utility for Control Signal

**ROUTINE DESCRIPTION:**

This routine tests the CTLI Register by rotating a bit pattern through the register.

**PARAMETERS: 1**

BYTE NUMBER	VALUE LIMIT	DESCRIPTION
01	00-FE	Delay = (Value) X 128 microseconds.
	FF	Single cycle.

**ROUTINE ID (HEX):** 3E

**ROUTINE NAME:** Pack Spin Up Utility

**ROUTINE DESCRIPTION:**

This utility routine allows the FE to spin up the stack with CB2 OFF.

**PARAMETERS: 1**

<b>BYTE NUMBER</b>	<b>VALUE LIMIT</b>	<b>DESCRIPTION</b>
01	00-FE	Delay = (Value) X 128 microseconds.
	FF	Single cycle.

**ROUTINE ID (HEX):** 3F

**ROUTINE NAME:** Pack Spin Down Utility

**ROUTINE DESCRIPTION:**

This routine allows the FE to spin down the stack during troubleshooting without using the START/STOP switch.

**PARAMETERS: 1**

<b>BYTE NUMBER</b>	<b>VALUE LIMIT</b>	<b>DESCRIPTION</b>
01	00-FE	Delay = (Value) X 128 microseconds.
	FF	Single cycle.

**ROUTINE ID (HEX):** 40

**ROUTINE NAME:** CROM Read of DCL1 and 2

**ROUTINE DESCRIPTION:**

This utility routine allows the FE to read any location in CROM.

**PARAMETERS: 2**

BYTE NUMBER	VALUE LIMIT	DESCRIPTION
01	00-0F	High order address
02	00-FF	Low order address

**ROUTINE ID (HEX):** 45

**ROUTINE NAME:** Zero RAM Read

**ROUTINE DESCRIPTION:**

This utility routine zeros designated RAM locations. These locations are 1832, 1838-184C and 1888.

**PARAMETERS: 1**

BYTE NUMBER	VALUE LIMIT	DESCRIPTION
01	00-FE	Delay = (Value) X 128 microseconds.
	FF	Single cycle.

**ROUTINE ID (HEX):** 46

**ROUTINE NAME:** Tachometer Calibration

**ROUTINE DESCRIPTION:**

This utility routine calibrates the tachometer circuitry.

**PARAMETERS: 1**

<b>BYTE NUMBER</b>	<b>VALUE LIMIT</b>	<b>DESCRIPTION</b>
01	00-FE	Delay = (Value) X 128 microseconds.
	FF	Single cycle.

**ROUTINE ID (HEX):** 47

**ROUTINE NAME:** Test Initialization Routines

**ROUTINE DESCRIPTION:**

This utility routine runs all microdiagnostic routines executed during initialization.

**PARAMETERS: 1**

<b>BYTE NUMBER</b>	<b>VALUE LIMIT</b>	<b>DESCRIPTION</b>
01	00-FE	Delay = (Value) X 128 microseconds.
	FF	Single cycle.

### **3.6 MICRODIAGNOSTIC ROUTINE FLOWCHARTS**

This section contains flowcharts for each routine which should help the FE understand what each routine is doing.

SEEK-SEEK ROUTINE (ROUTINE CODE = 10)

THIS ROUTINE CAUSES THE DRIVE TO PERFORM ALTERNATE SEEKS BETWEEN TWO SPECIFIED CYLINDERS. ANY SEEK IN-COMPLETES WILL CAUSE AN ERROR CODE TO BE DISPLAYED IN THE DATA DISPLAY ON THE FE PANEL. THIS ROUTINE REQUIRES SIX PARAMETERS.

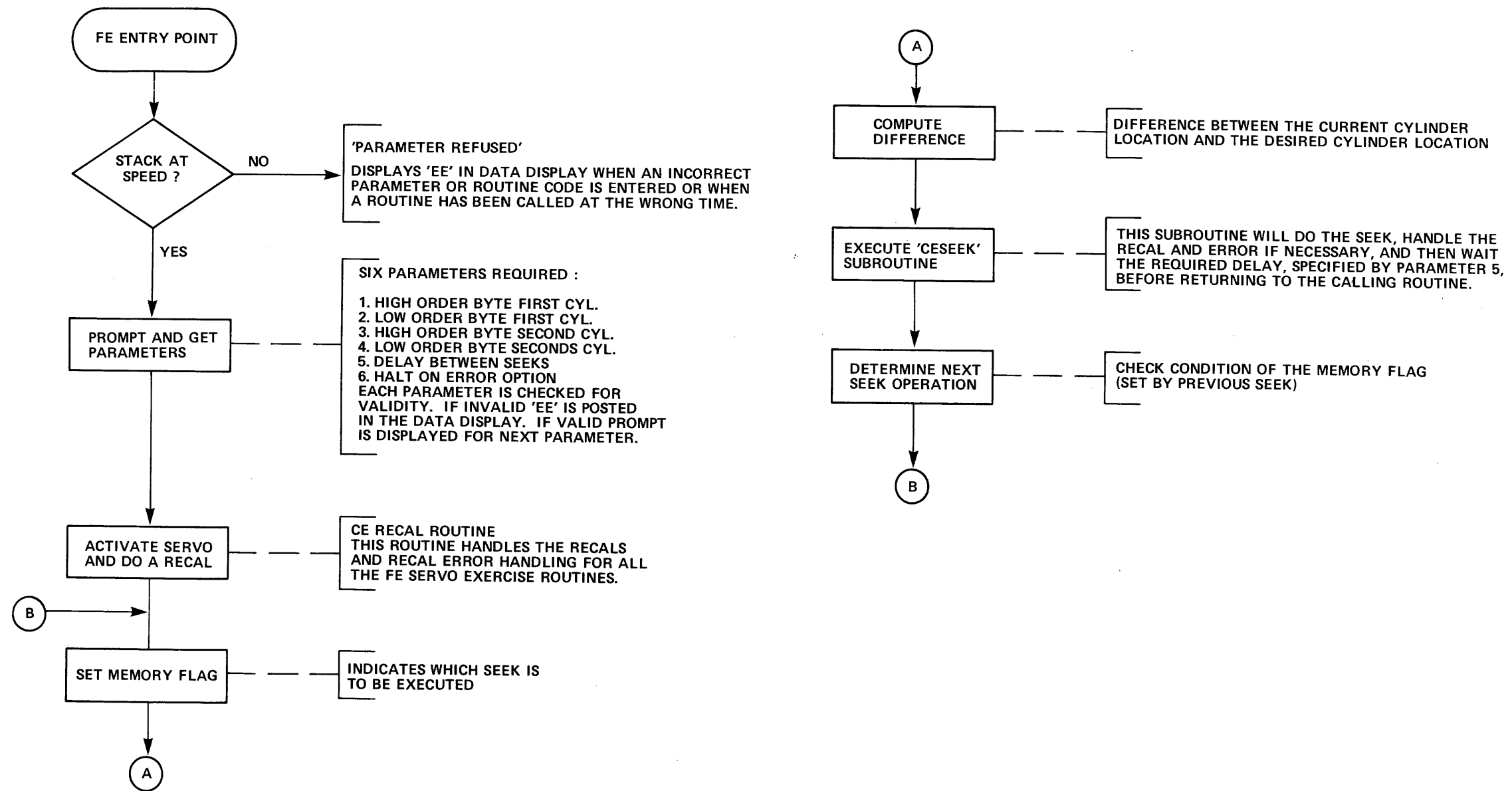

PB001837-25

Figure 3-6-1 Seek-Seek (RTN 10)



INCREMENTAL SEEK ROUTINE (ROUTINE CODE = 11)

THIS ROUTINE CAUSES TYPE DRIVE TO PERFORM CONSECUTIVE SEEKS TO CYLINDERS SEPARATED BY THE SPECIFIED INCREMENT. ANY SEEK INCOMPLETES WILL CAUSE AN ERROR CODE TO BE DISPLAYED IN THE DATA DISPLAY ON THE FE PANEL. THIS ROUTINE REQUIRES THREE PARAMETERS.

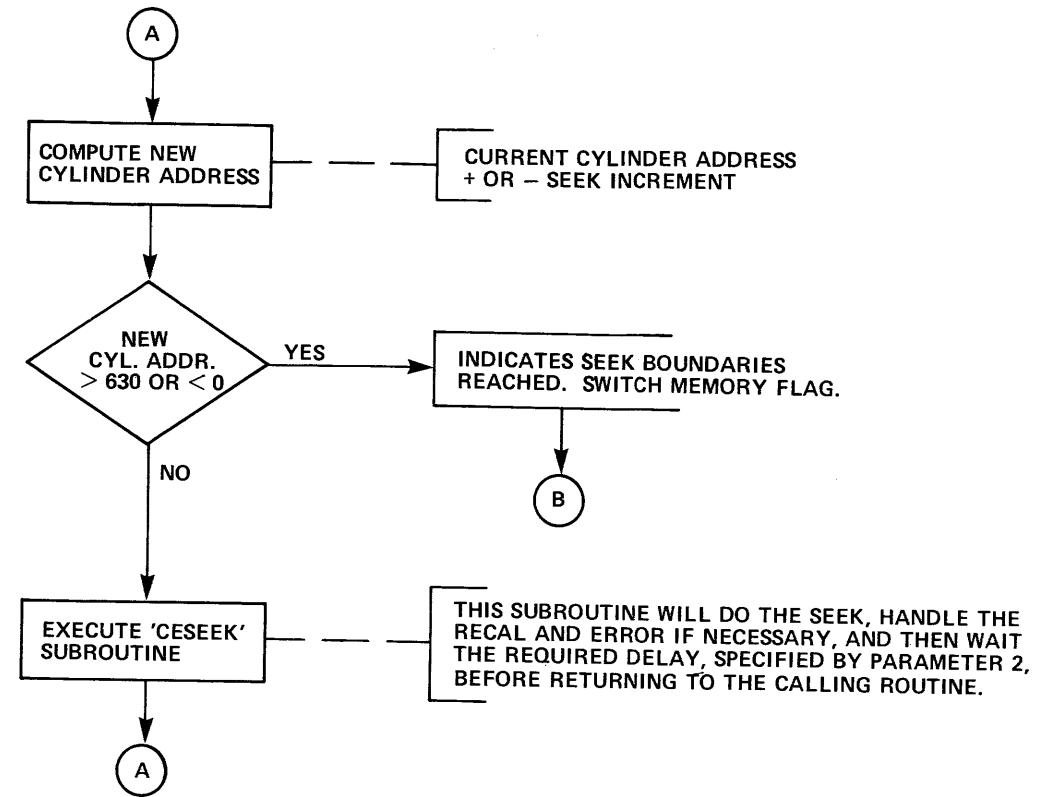
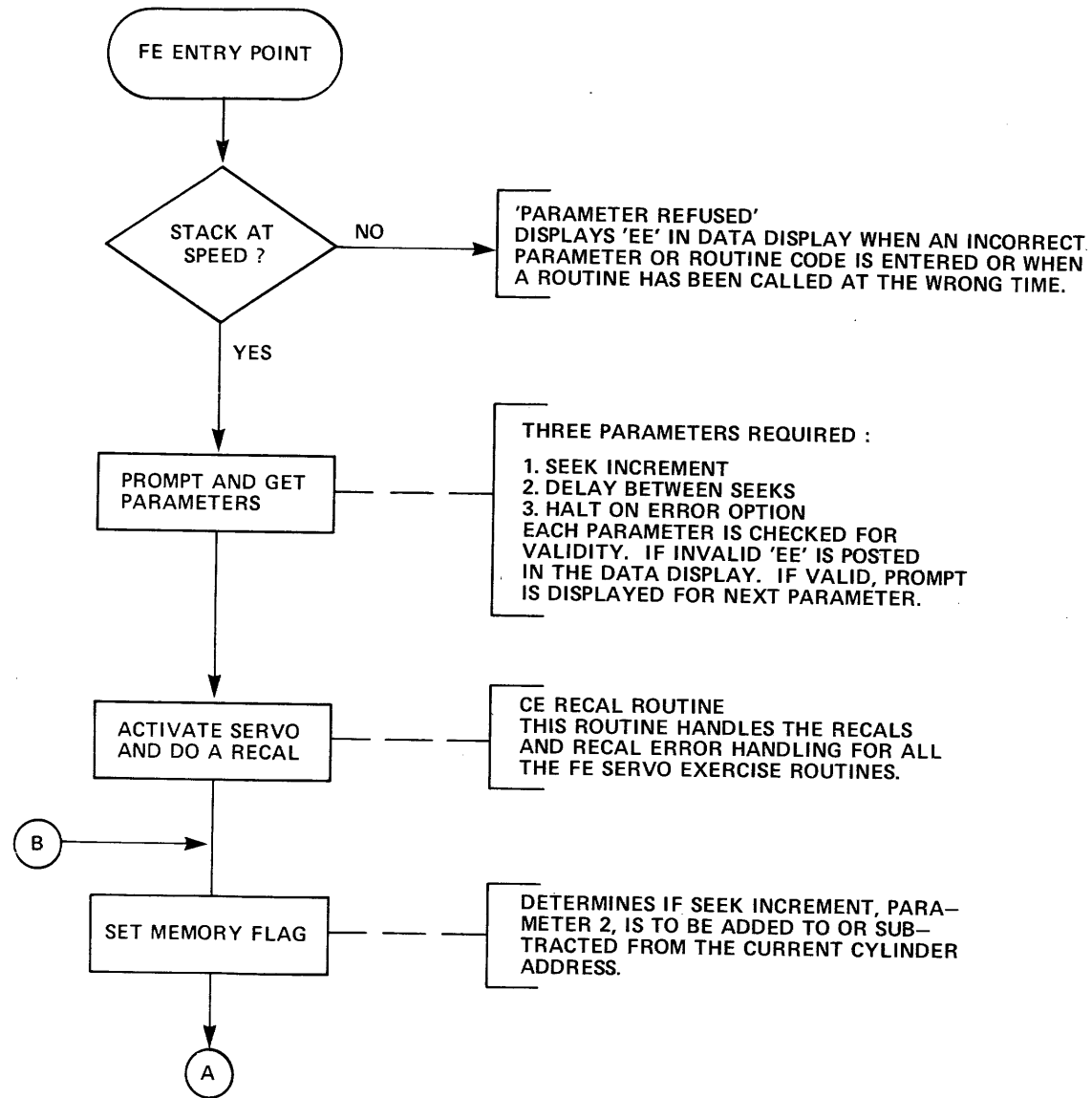

PB001837-32

Figure 3-6-2 Incremental Seek (RTN 11)

RANDOM SEEK ROUTINE (ROUTINE CODE = 12)

THIS ROUTINE CAUSES THE DRIVE TO PERFORM SEEKS TO RANDOM CYLINDERS. ANY SEEK INCOMPLETES WILL CAUSE AN ERROR CODE TO BE DISPLAYED IN THE DATA DISPLAY ON THE FE PANEL. THIS ROUTINE REQUIRES 2 PARAMETERS.

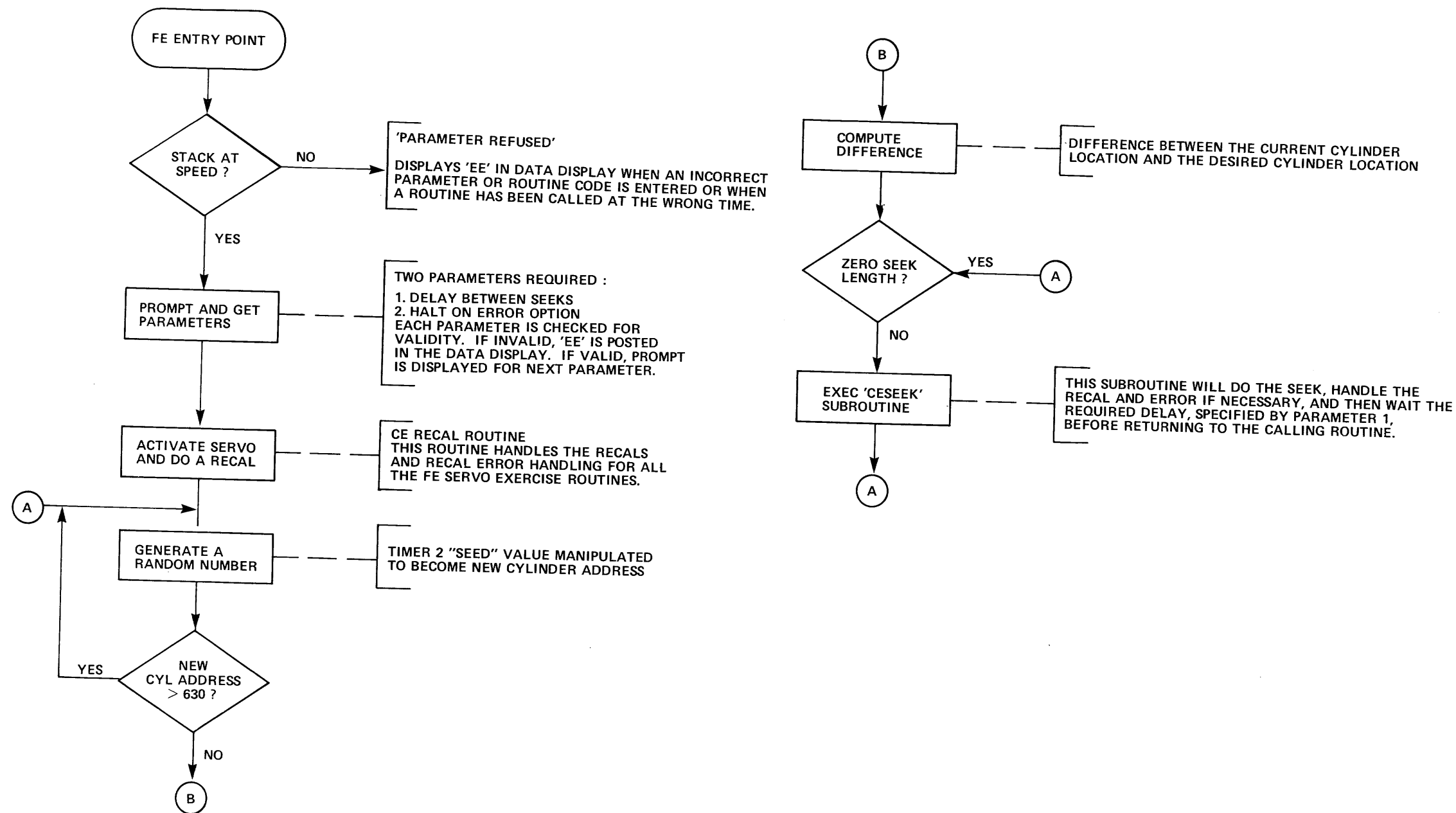

PB001837-30

Figure 3-6-3 Random Seek (RTN 12)

RECAL -- RECAL ROUTINE (ROUTINE CODE = 13)

THIS ROUTINE CAUSES THE DRIVE TO PERFORM SUCCESSIVE RECALLS. ANY INCOMPLETES WILL CAUSE AN ERROR CODE TO BE DISPLAYED IN THE DATA DISPLAY ON THE FE PANEL. THIS ROUTINE REQUIRES TWO PARAMETERS.

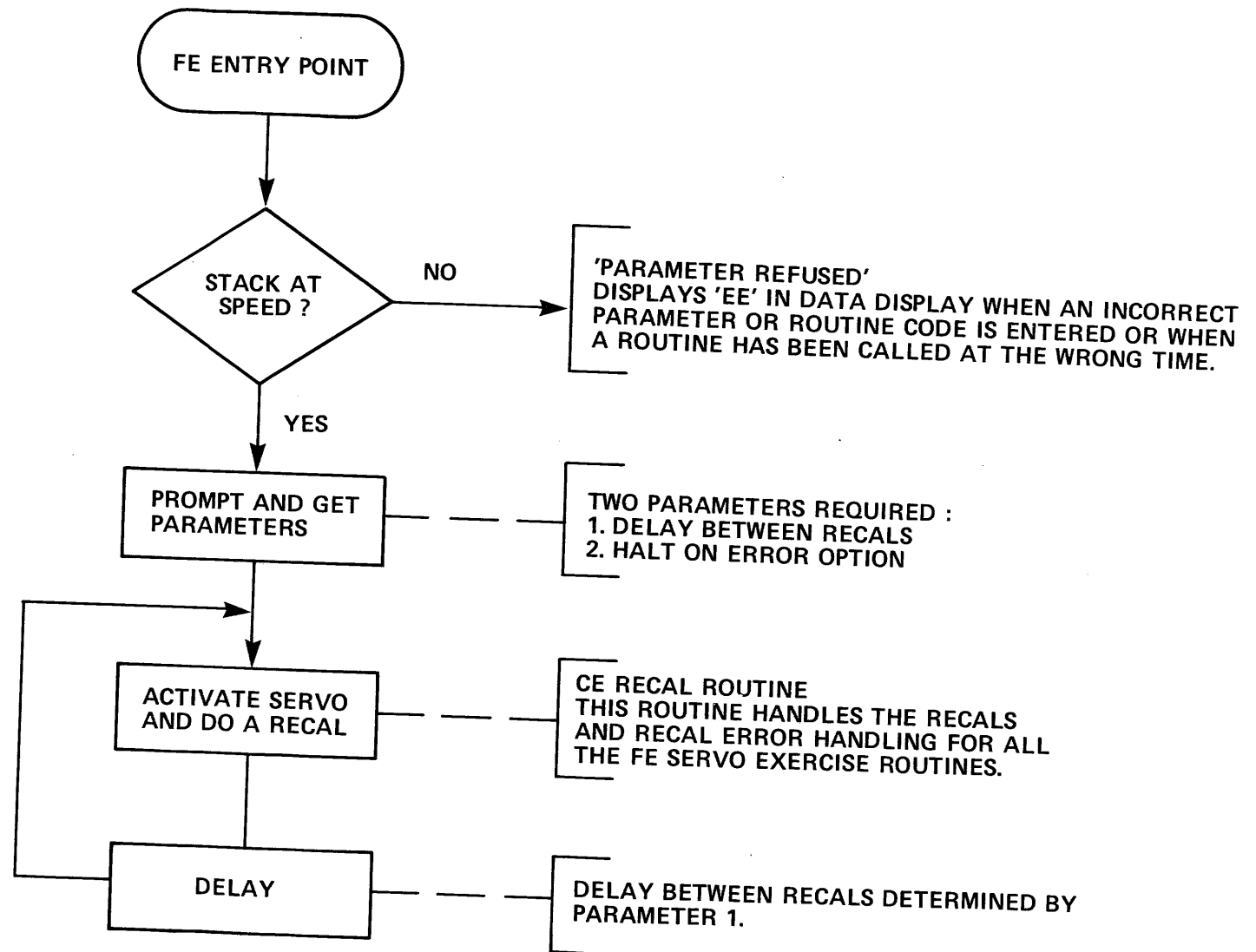

PB001837-31

Figure 3-6-4 Recal-Recal (RTN 13)

TACHOMETER DIAGNOSTICS (ROUTINE NUMBER = 14)  
A TEST OF THE TACHOMETER CIRCUITRY.

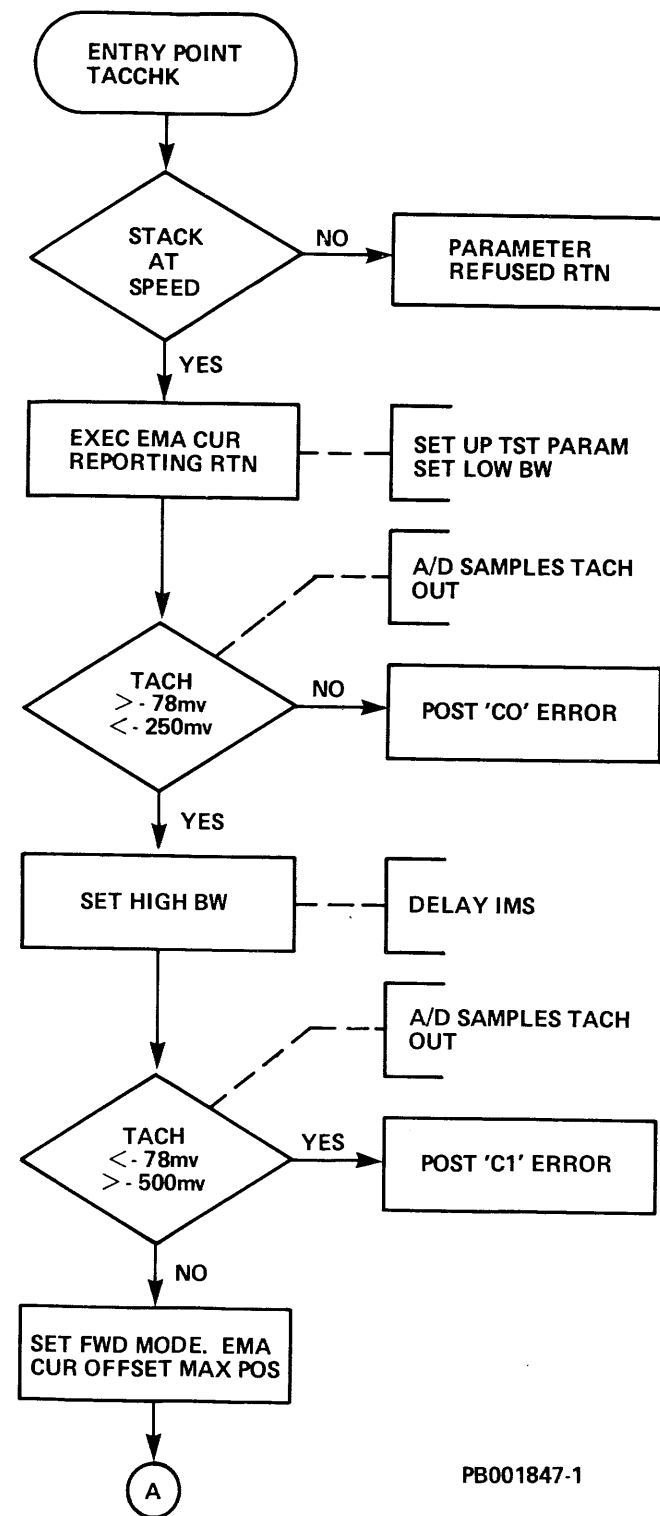

PB001847-1

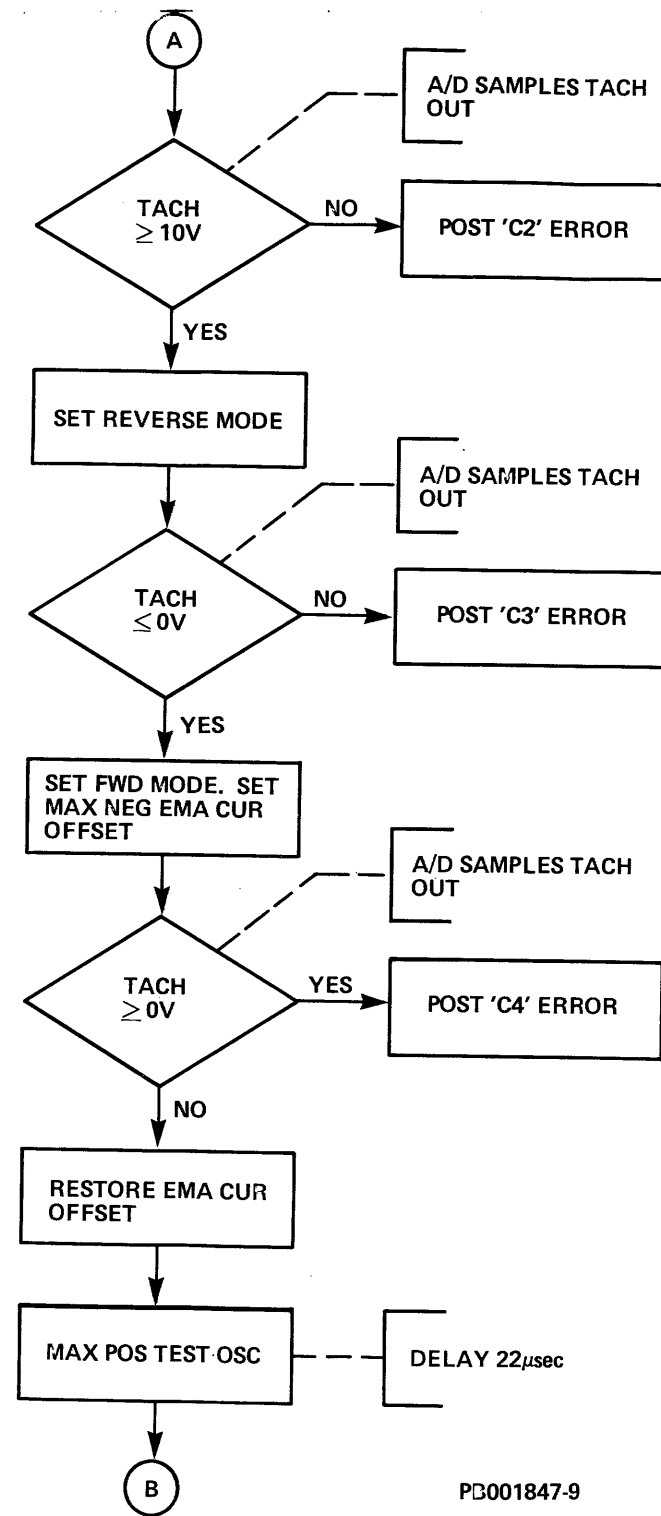

PB001847-9

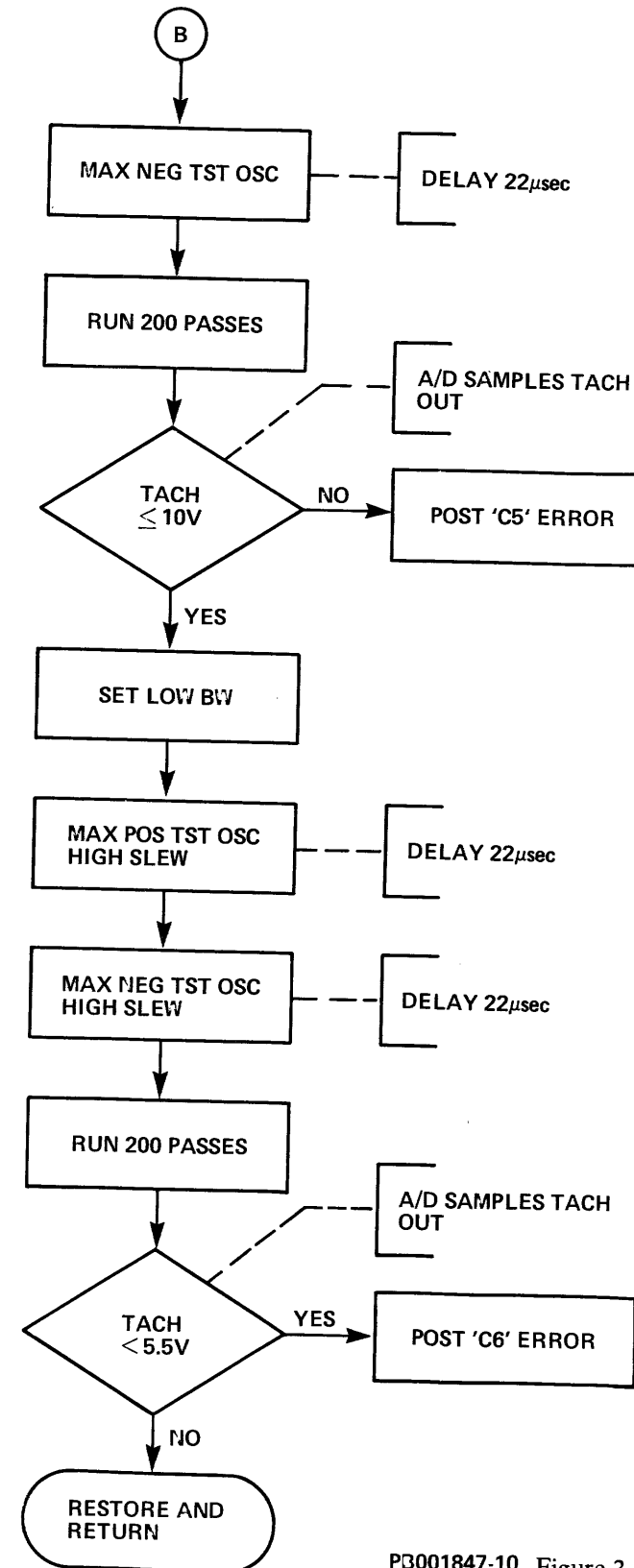

PB001847-10 Figure 3-6-5 Tachometer Diagnostics (RTN 14)

LAMP TEST ROUTINE (ROUTINE CODE = 15)

THIS ROUTINE TESTS THE LAMPS AND SWITCHES ON THE OPERATOR PANEL AND THE FE PANEL AS WELL AS THE LEDS ON THE A1A7 AND A1A9 PCAS. NO PARAMETERS ARE REQUIRED FOR THIS ROUTINE.

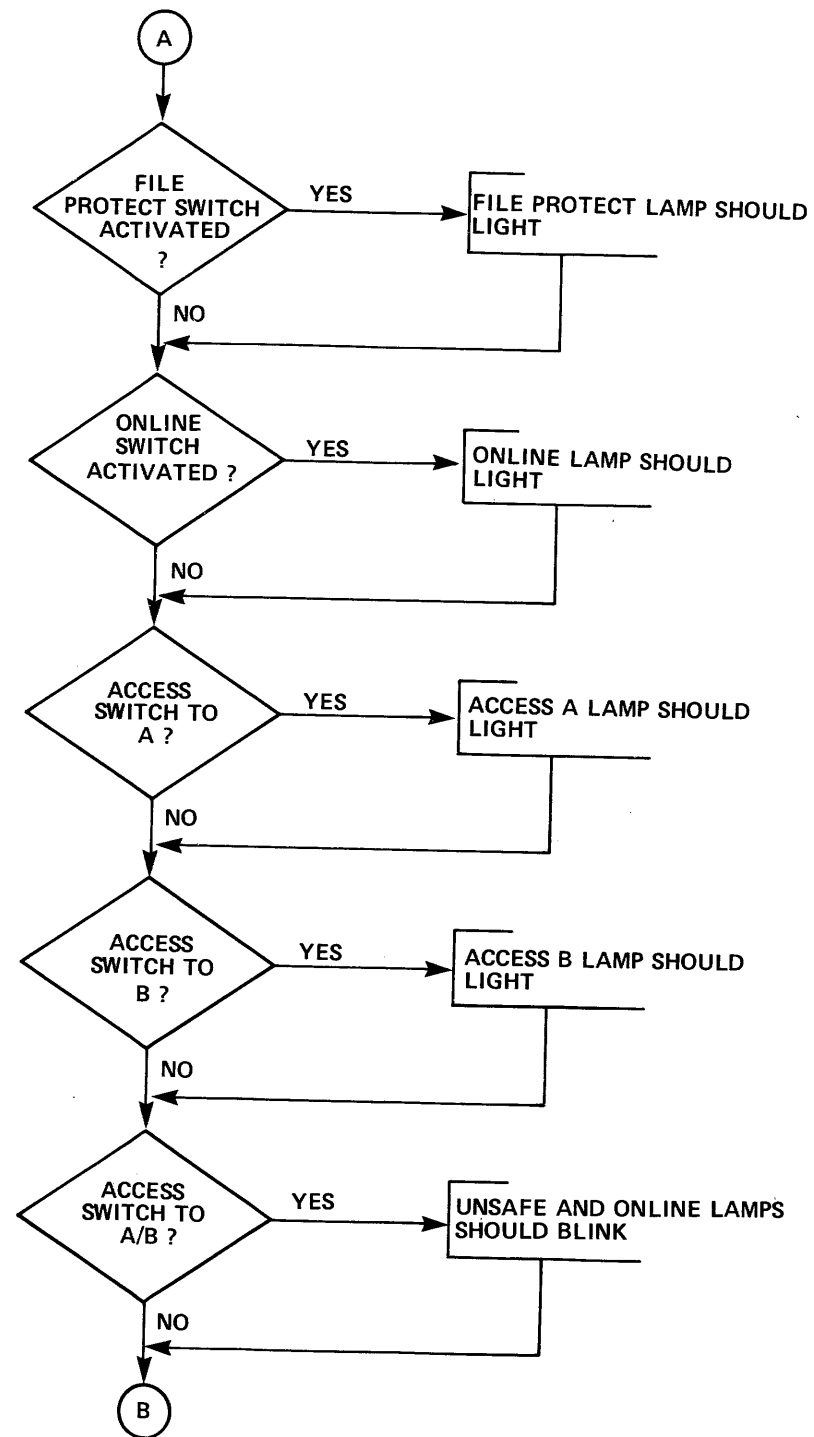
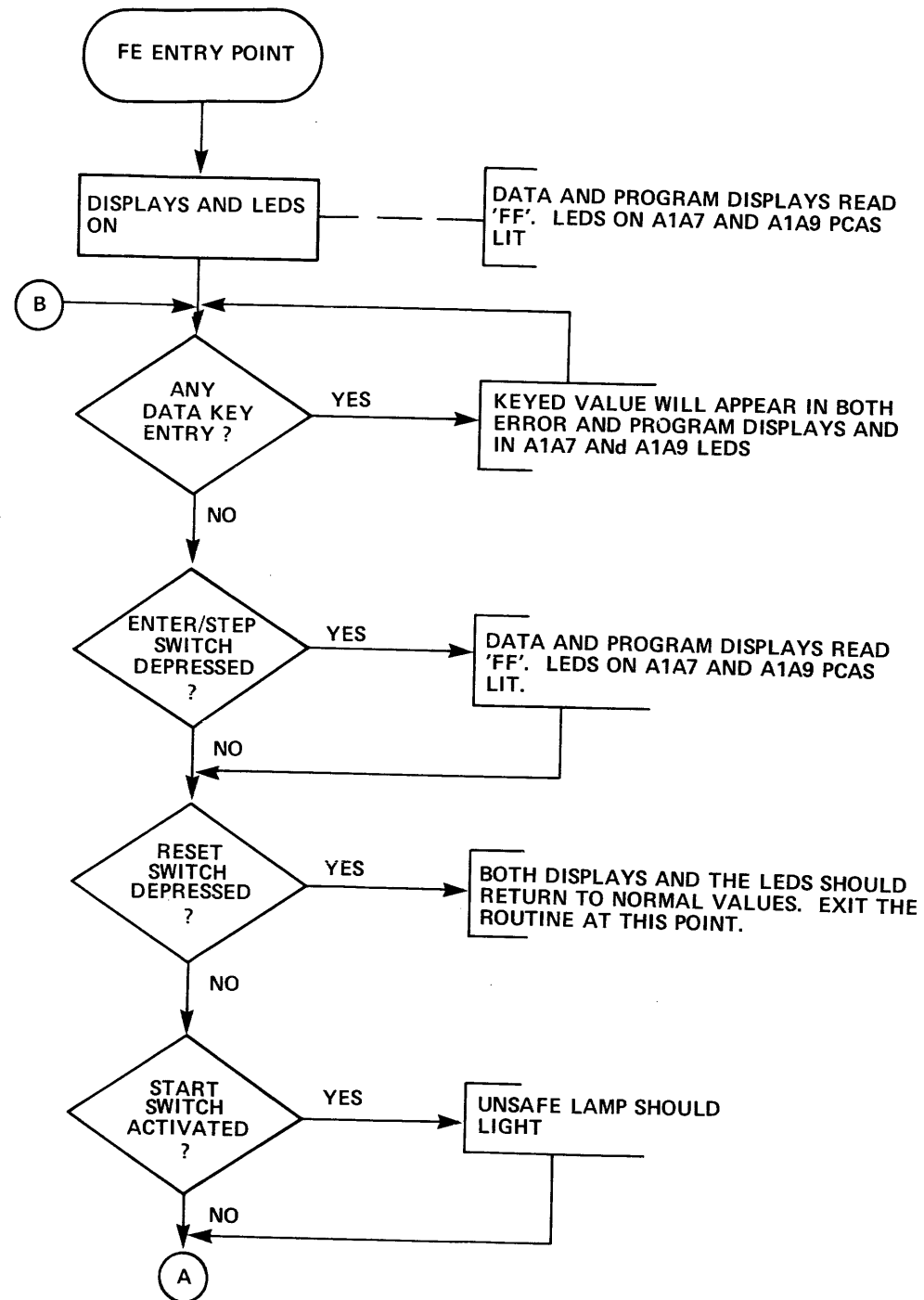

PB001837-24

Figure 3-6-6 Indicator Test (RTN 15)

CONTROL PANEL DIAGNOSTICS (ROUTINE NUMBER = 16)  
TESTS OPERATOR CONTROL PANEL AND FE PANEL FOR  
PROPER OPERATION OF INDICATOR LAMPS.

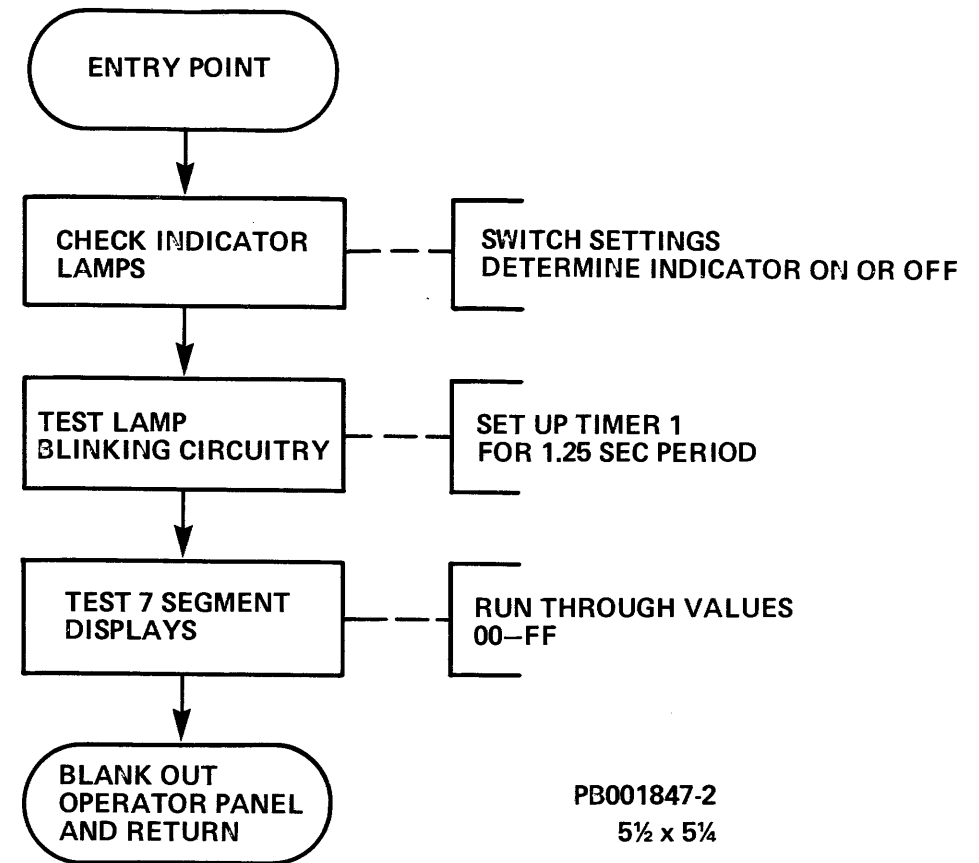
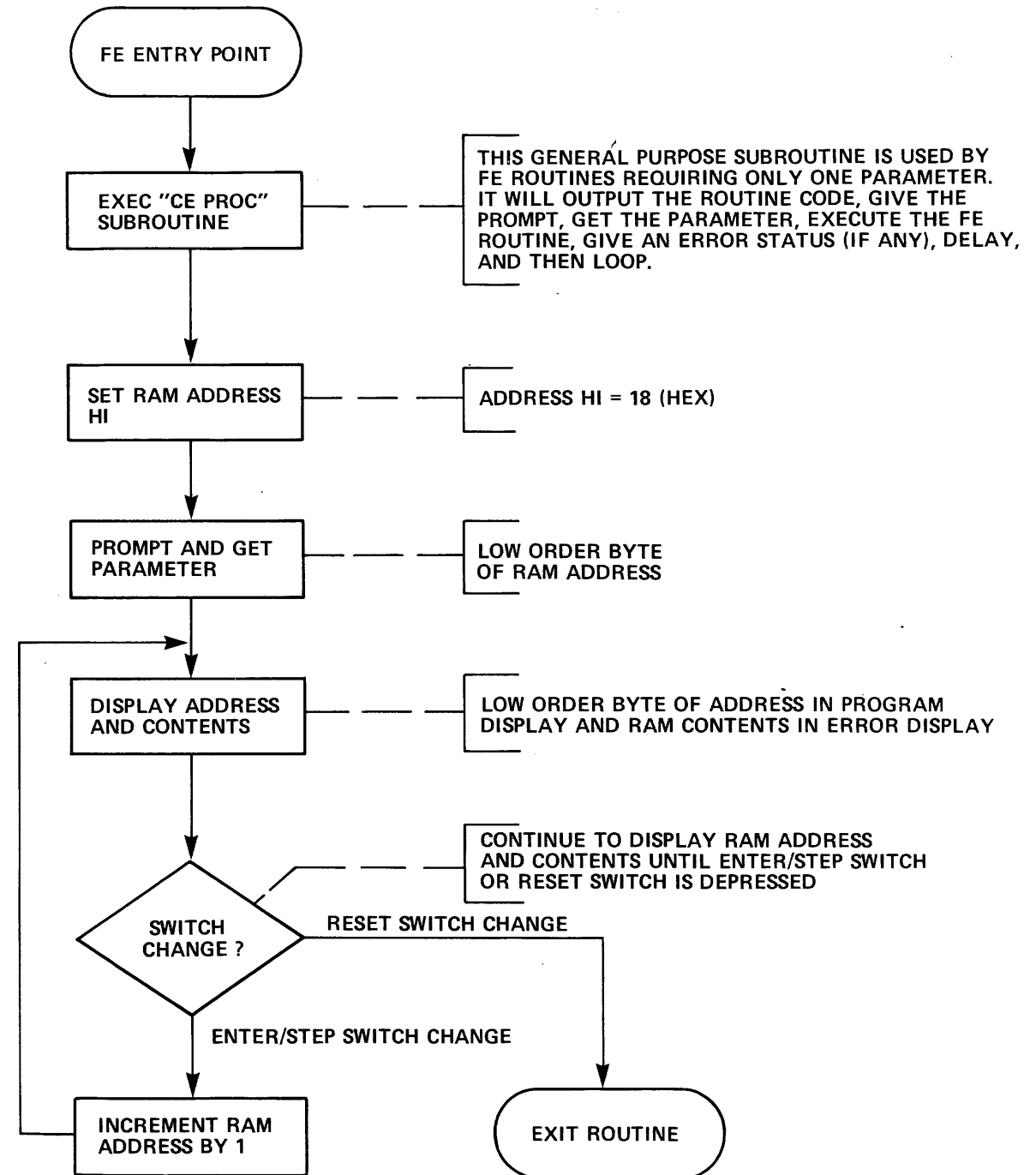
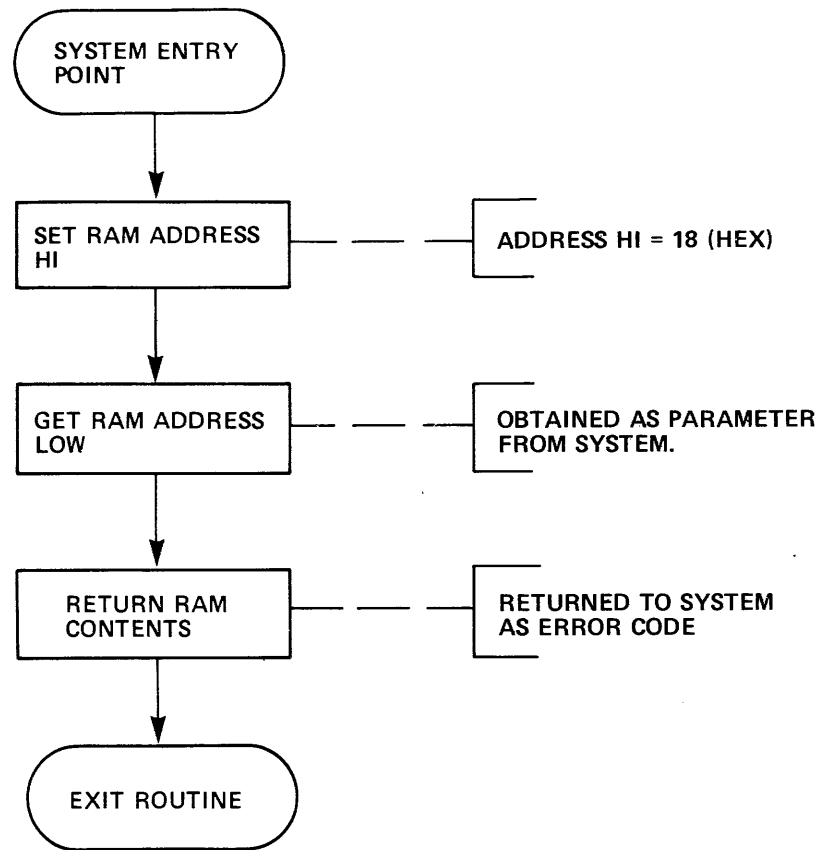

Figure 3-6-7 FE Control Panel Test (RTN 16)

READ RAM ROUTINE (ROUTINE CODE = 17)

THIS ROUTINE WILL READ DATA FROM RAM AND CAN BE EXECUTED IN EITHER LOCAL OR ONLINE MODE. IN LOCAL MODE THE ROUTINE REQUIRES ONE PARAMETER, THE LOW ORDER BYTE OR RAM ADDRESS, AND WILL DISPLAY THE CONTENTS OF THAT RAM ADDRESS IN THE ERROR CODE DISPLAY. EVERY TIME THE ENTER/STEP SWITCH IS DEPRESSED THE RAM ADDRESS INCREMENTS BY ONE. DEPRESSING THE RESET SWITCH WILL STOP THE ROUTINE. IN ONLINE MODE ONLY THE ADDRESSED RAM CAN BE READ. INCREMENTING THROUGH THE ADDRESSES IS NOT POSSIBLE. THE RAM CONTENTS ARE RETURNED TO THE SYSTEM AN AN ERROR CODE.



PB001837-27

Figure 3-6-8 RAM Read (RTN 17)

PLO UNSAFE ROUTINE (ROUTINE CODE = 18)

THIS ROUTINE TESTS THE PLO UNSAFE AND INDEX TIMING CIRCUITRY. PLO UNSAFE IS TESTED BY SIMULATING AN UNSAFE CONDITION AND TESTING TO BE SURE THAT AN UNSAFE HAS OCCURRED. INDEX TIMING IS TESTED BY MEASURING THE TIME INTERVAL BETWEEN INDEX PULSES AND VERIFYING IT IS WITHIN 3% OF THE SPECIFIED LIMIT.

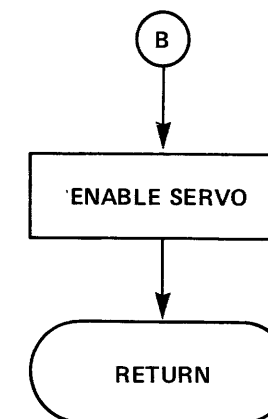
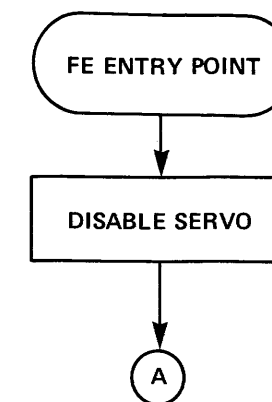
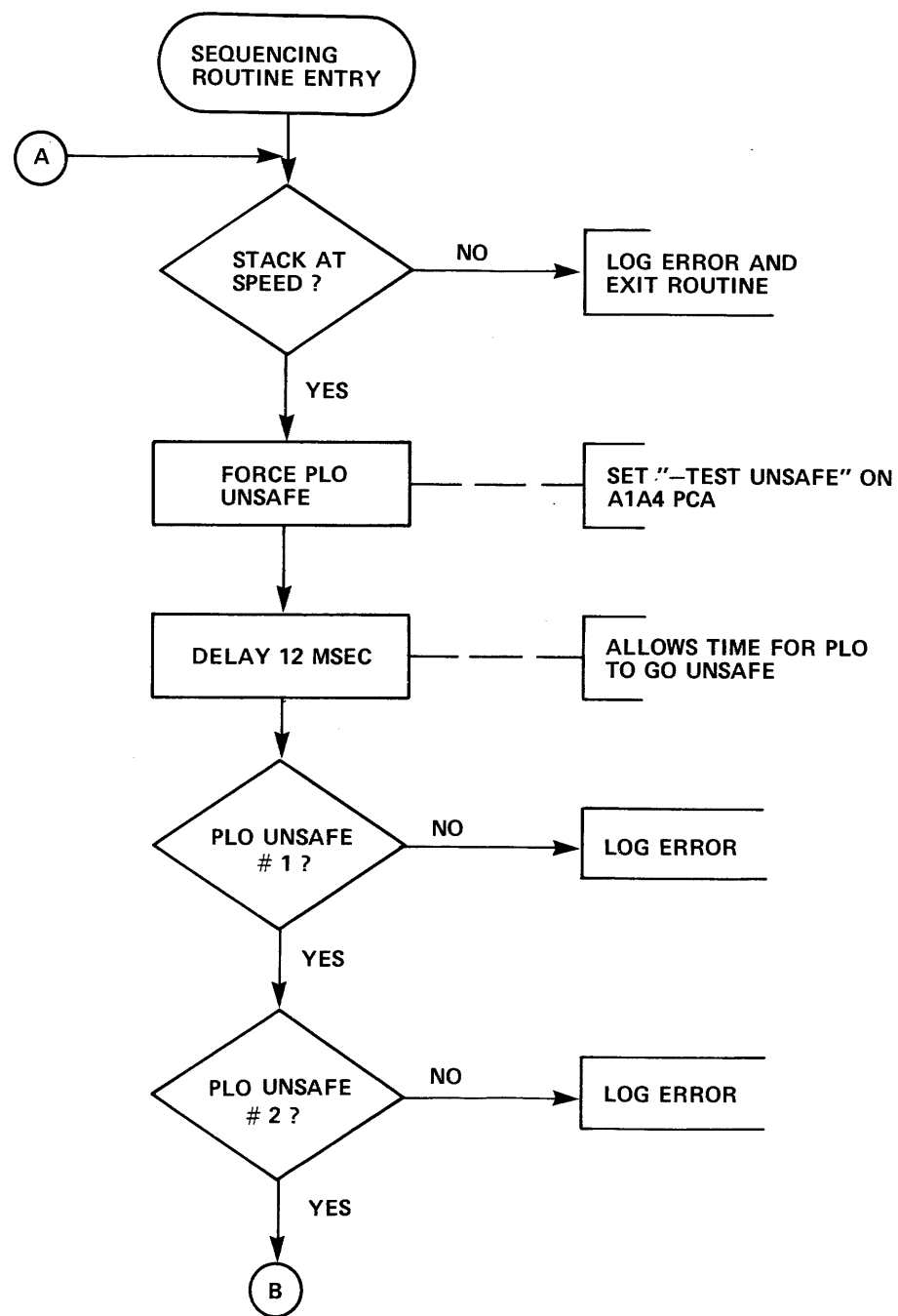

PB001837-29

Figure 3-6-9 PLO Unsafe (RTN 18)



EMA CURRENT REPORTING ROUTINE (ROUTINE CODE = 19)  
 THIS ROUTINE TESTS THE PULSER/DRIVER CIRCUITRY IN  
 ITS ABILITY TO RESPOND TO INPUT SIGNALS.

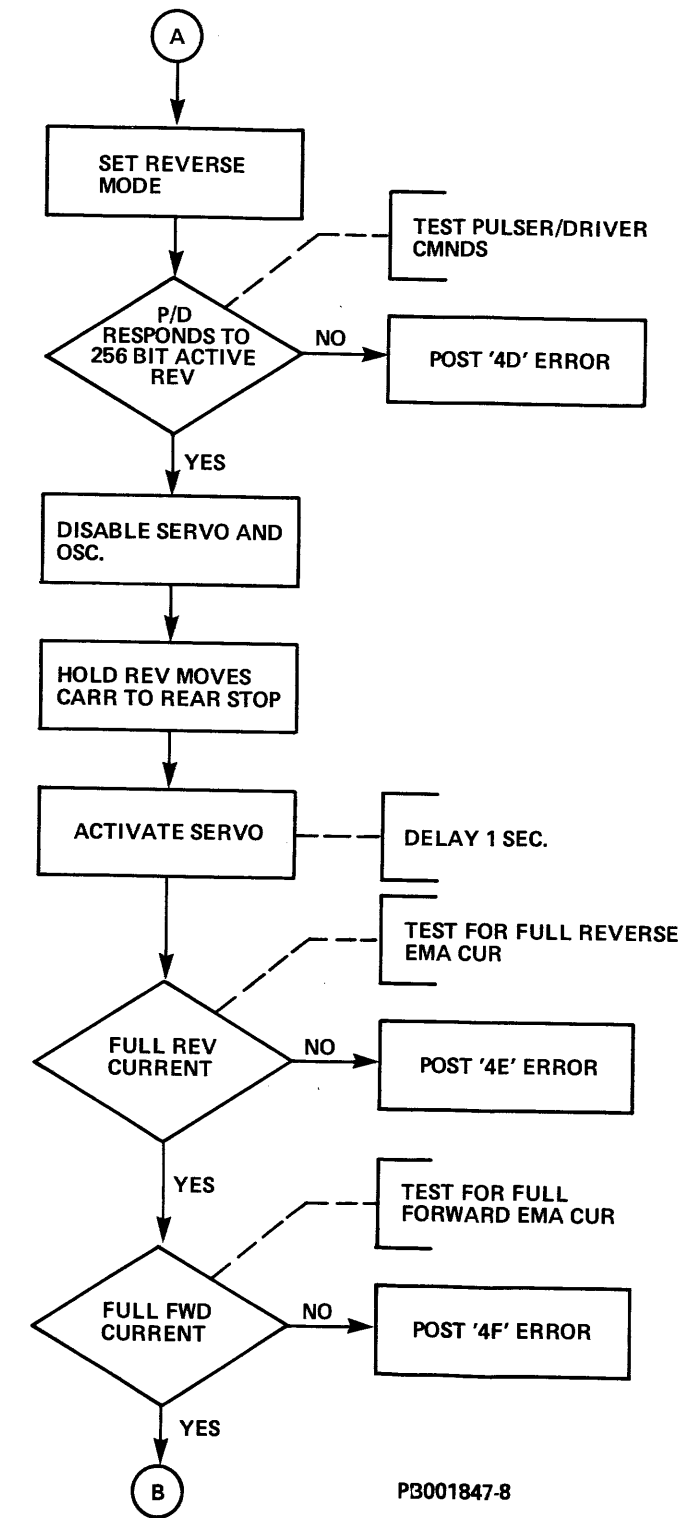
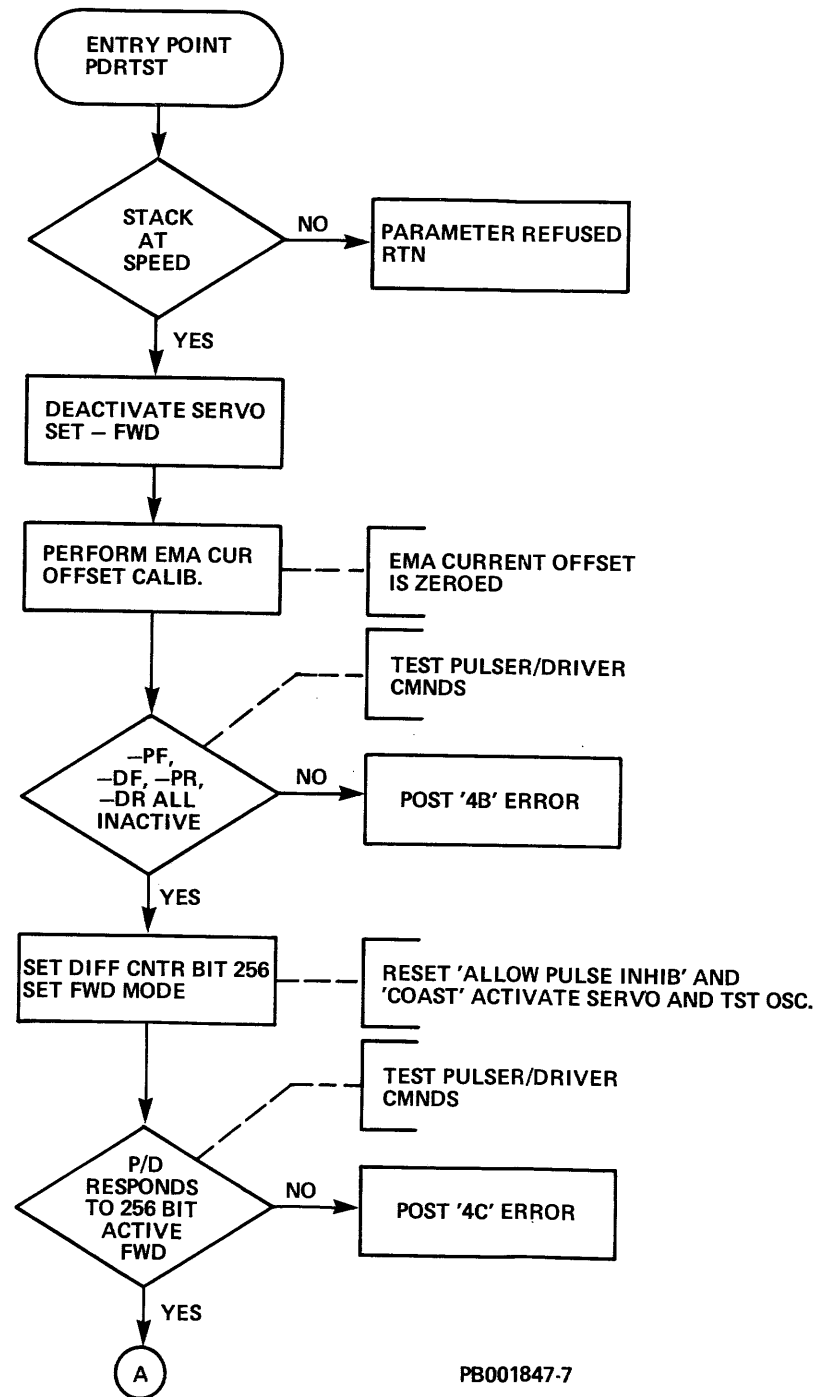

Figure 3-6-10 EMA Current Reporting (RTN 19)  
 Sheet 1 of 2

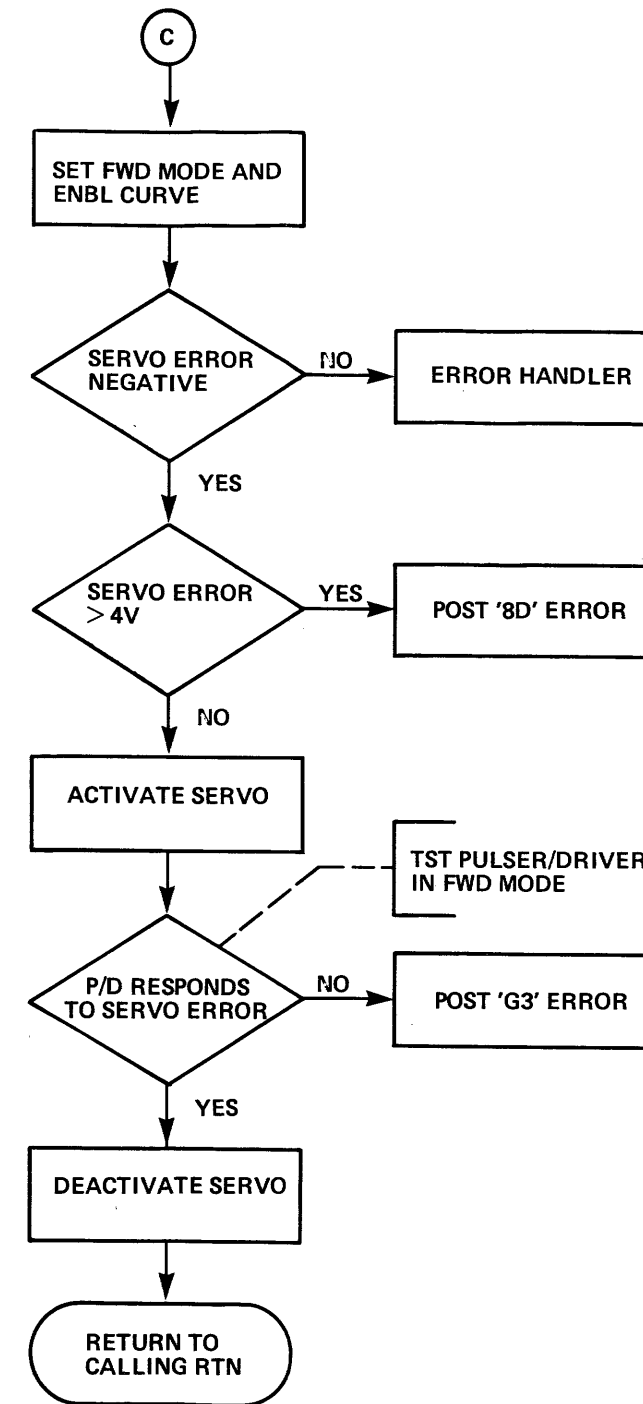
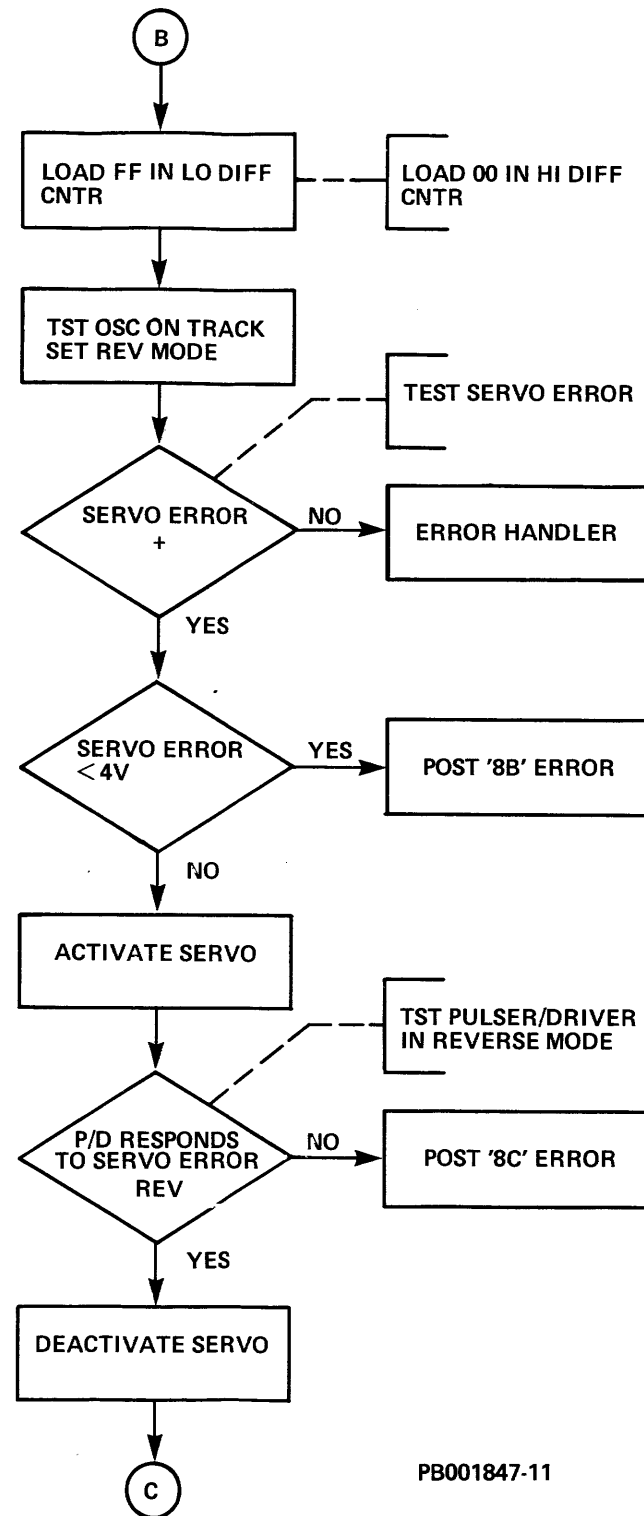
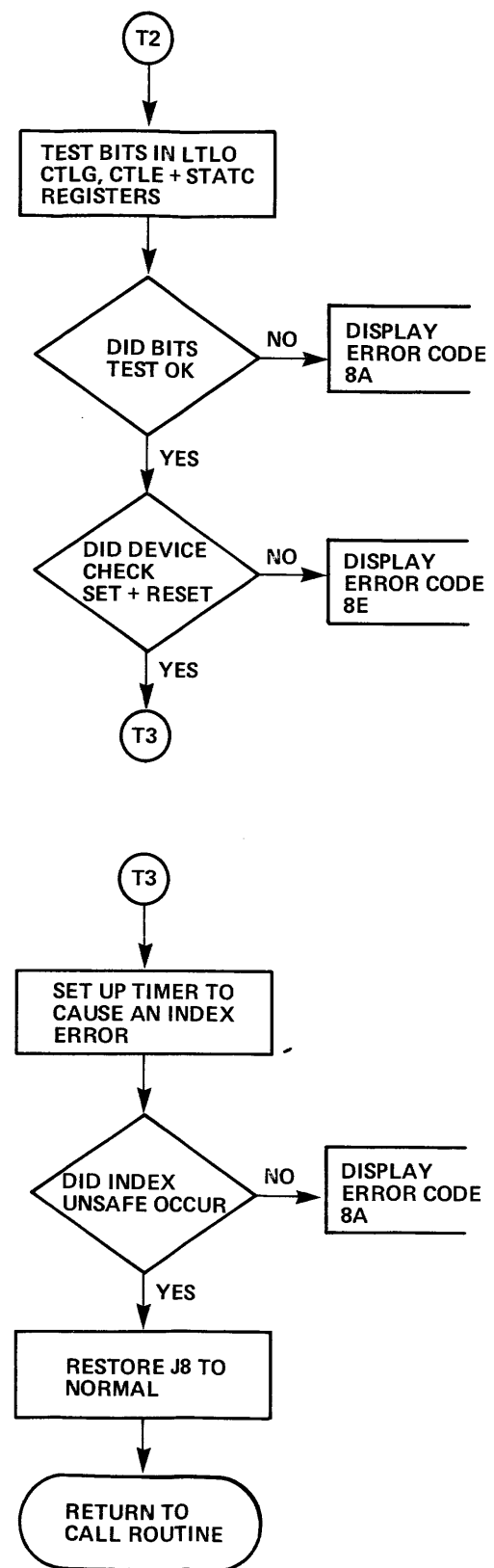
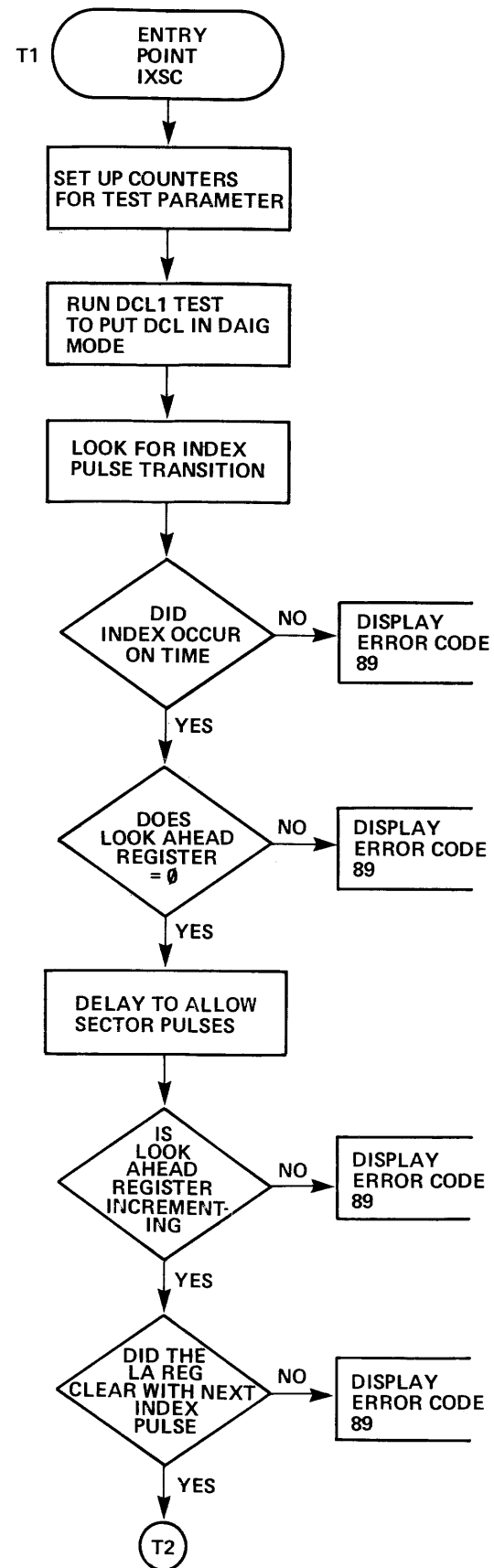

Figure 3-6-10 EMA Current Reporting (RTN 19)  
Sheet 2 of 2



INDEX/SECTOR/LOOK AHEAD REGISTER/CONTROL REGISTER TEST (ROUTINE CODE = 1A) THIS TEST IS IN 3.PARTS. T1 IS AN INDEX/SECTOR TIMING TEST, T2 CHECKS THE CONTROL REGISTERS, T3 CAUSES AN INDEX ERROR TO TEST THE INDEX UNSAFE BIT.

PB001846-13

Figure 3-6-11 Index/Sector/LA Register/Unsafe (RTN 1A)

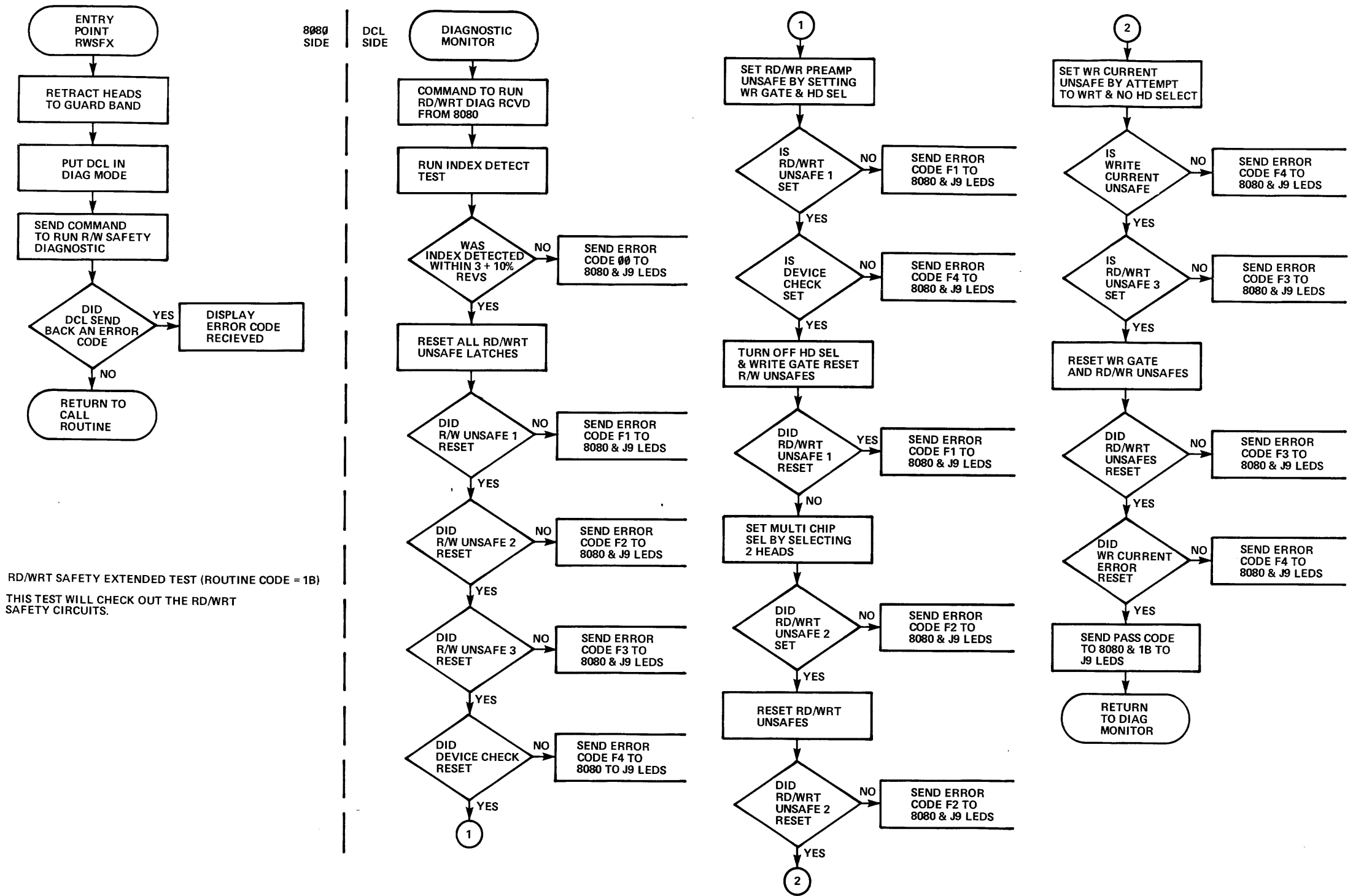

RD/WRT SAFETY EXTENDED TEST (ROUTINE CODE = 1B)  
THIS TEST WILL CHECK OUT THE RD/WRT SAFETY CIRCUITS.

PB001837-8

Figure 3-6-12 Read/Write Safety Extended (RTN 1B)

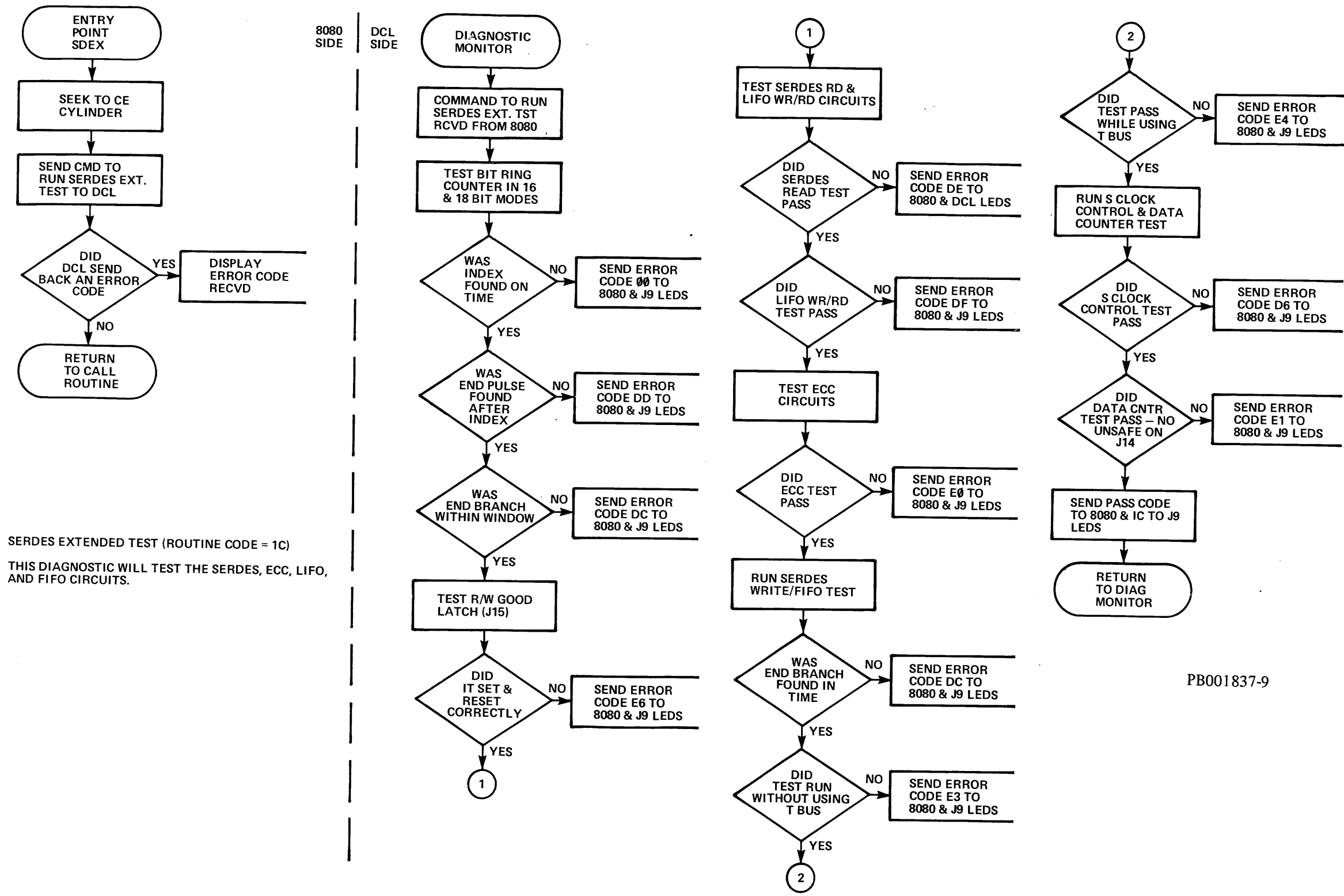

Figure 3-6-13 SERDES Extended (RTN 1C)

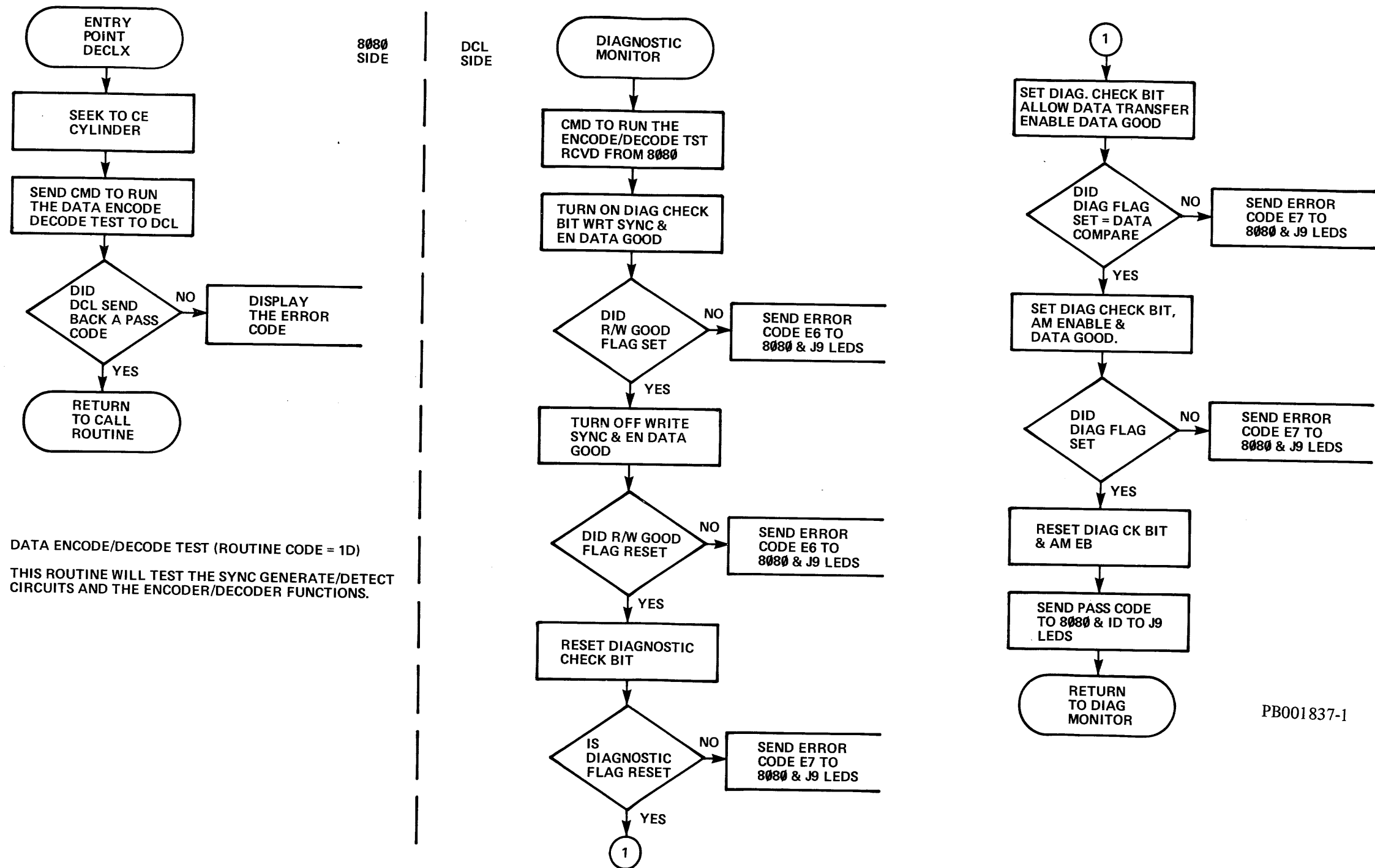
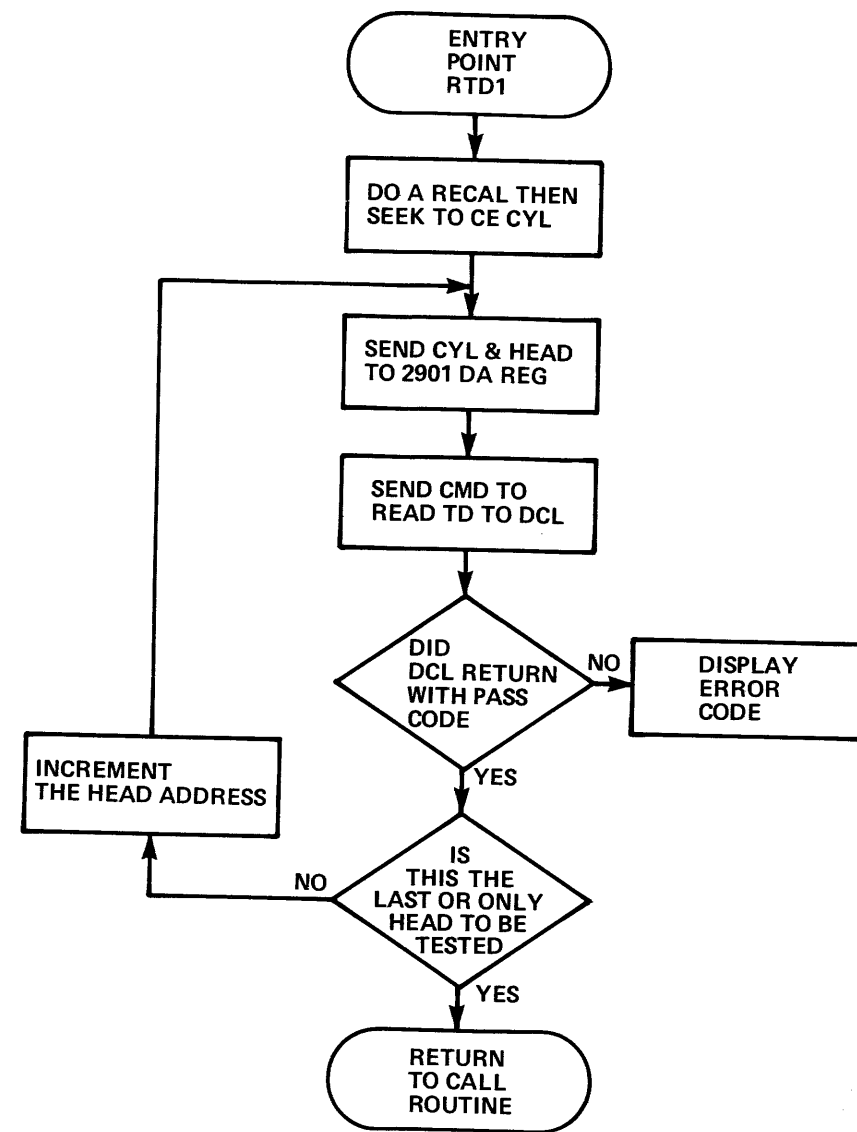

Figure 3-6-14 Data Encode/Decode (RTN 1D)



READ TRACK DESCRIPTOR TEST (ROUTINE CODE = 1E)  
 THIS TEST CHECKS FOR VALID CYLINDER (CE) AND HEAD THEN READS THE TRACK DESCRIPTOR AFTER INDEX.

8080  
SIDE

DCL  
SIDE

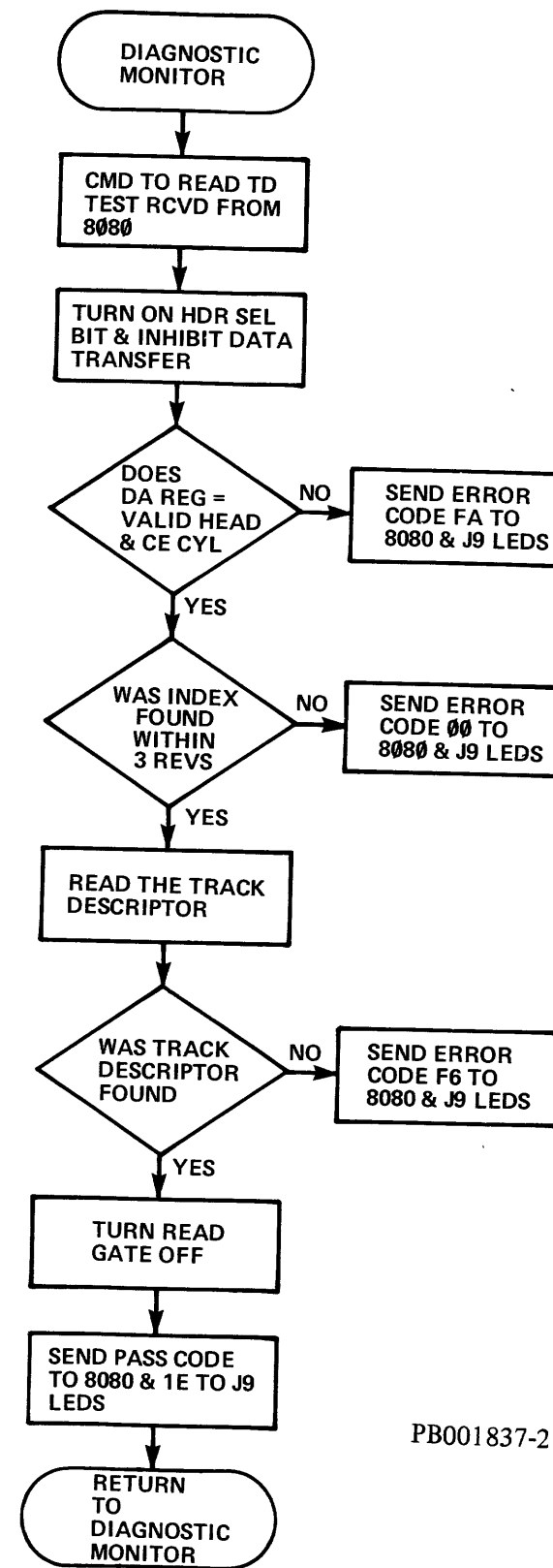

PB001837-2

Figure 3-6-15 Read Track Descriptor (RTN 1E)

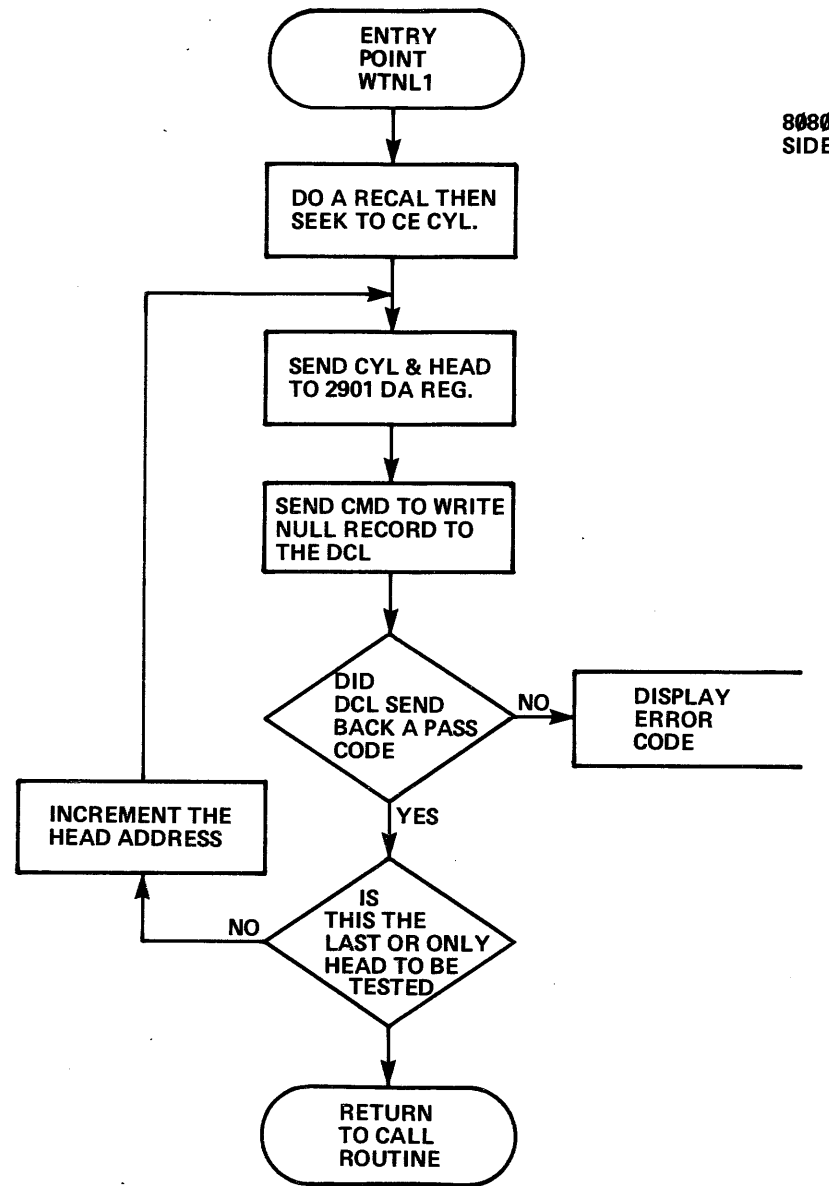

WRITE NULL TEST (ROUTINE CODE = 1F)

THIS TEST WILL READ THE TRACK DESCRIPTOR ON THE CE CYL, PAD THE TRACK WITH ZEROS FROM THE T.D. TO INDEX, THEN VERIFY THAT NO SYNC BYTE IS FOUND.

8080 SIDE

DCL SIDE

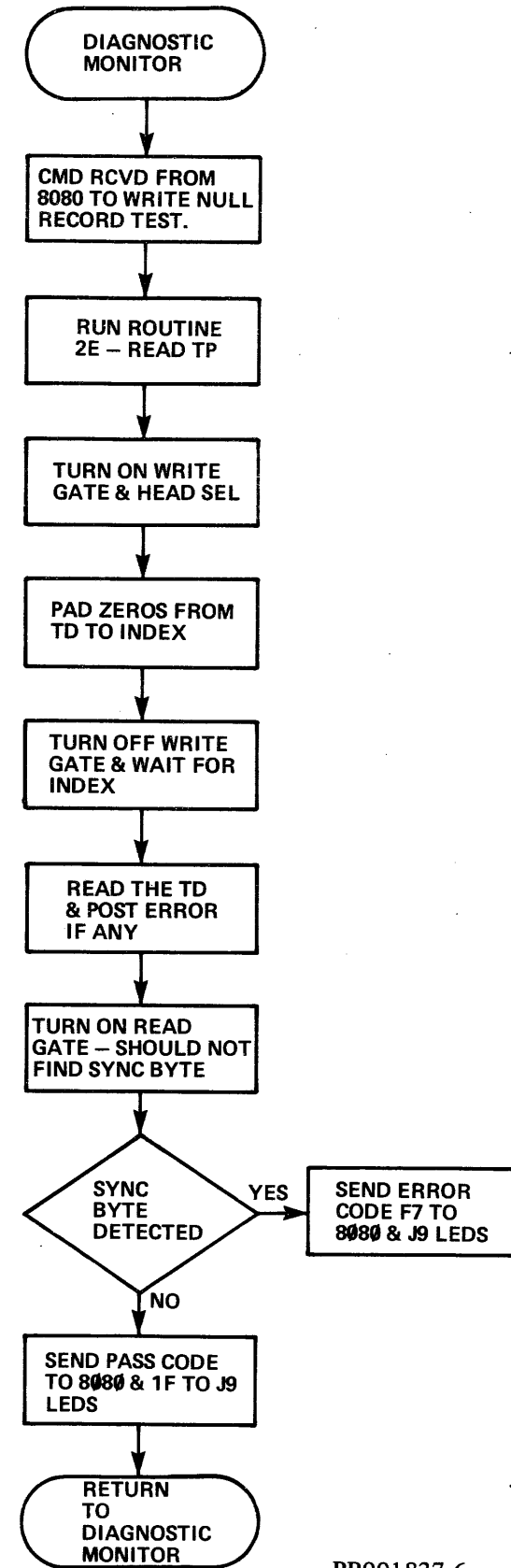

PB001837-6

Figure 3-6-16 Write Null (RTN 1F)



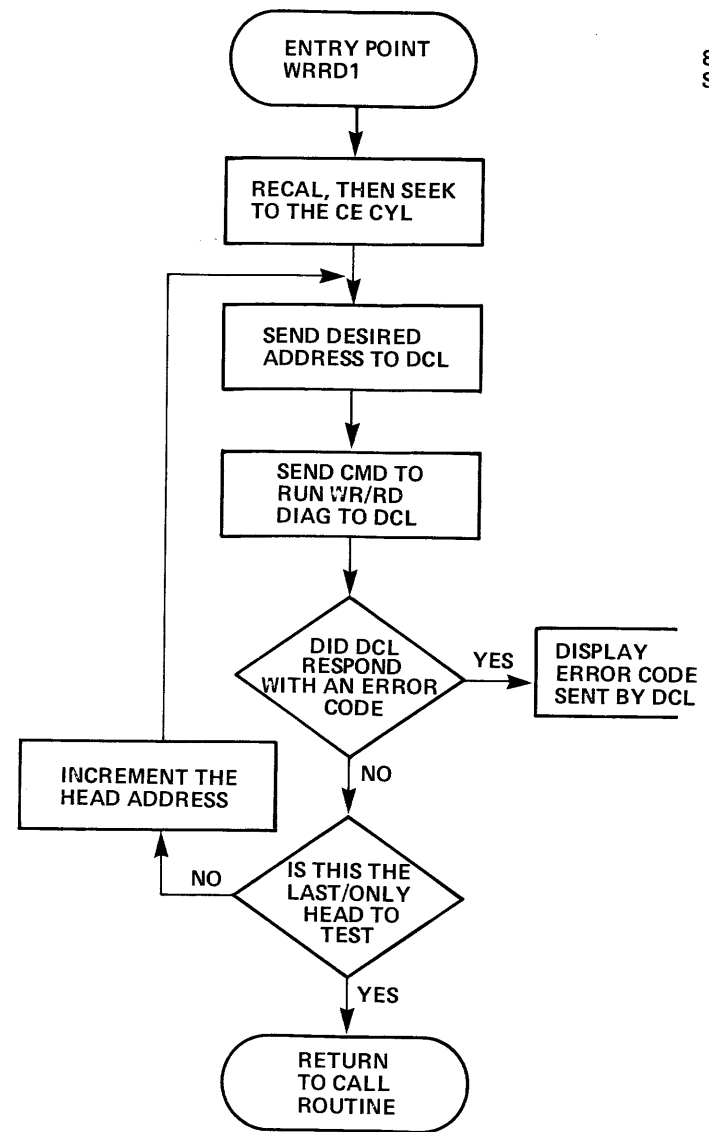

8080 SIDE | DCL SIDE

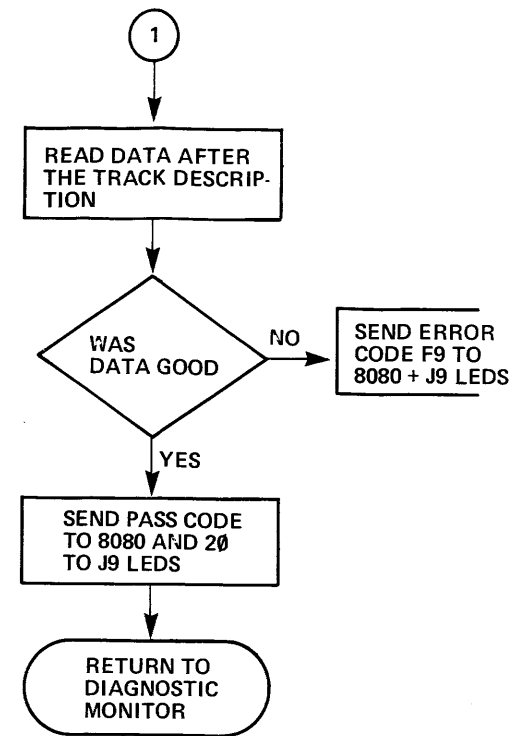
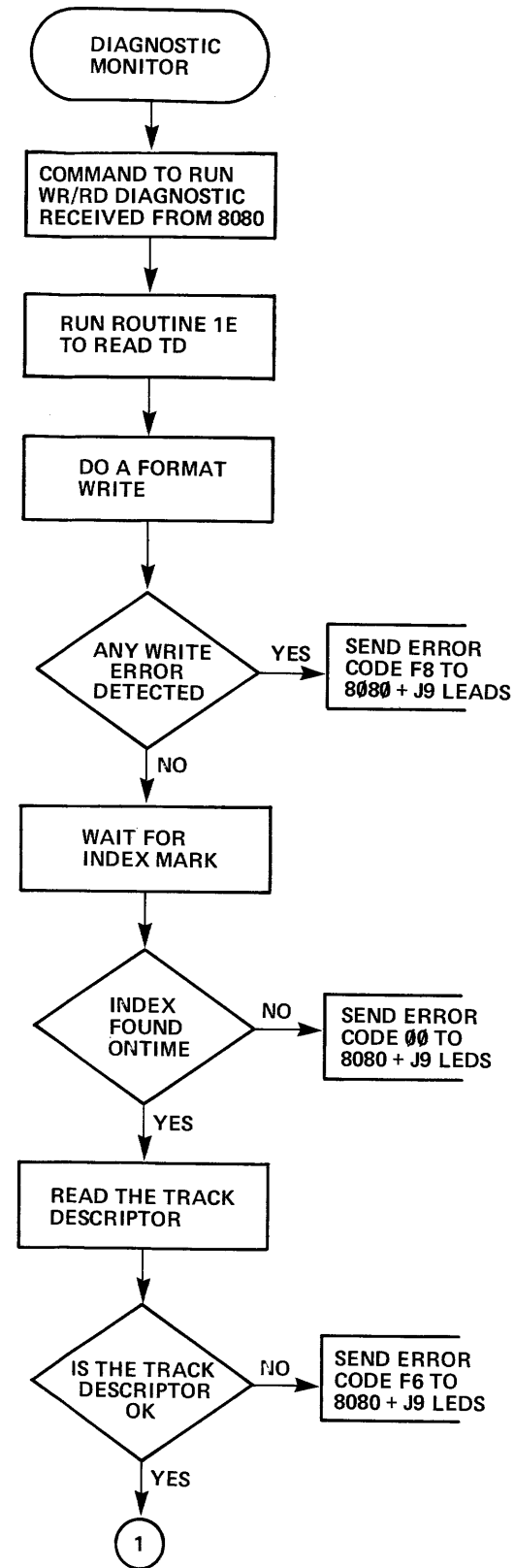

PB001846-3

WRITE AND READ DIAGNOSTICS (ROUTINE CODE = 20)  
 THIS ROUTINE READS THE TRACK DESCRIPTOR, WRITES DATA AFTER THE T.D. THEN READS THE DATA BACK AND CHECKS FOR DATA GOOD.

Figure 3-6-17 Write/Read (RTN 20)

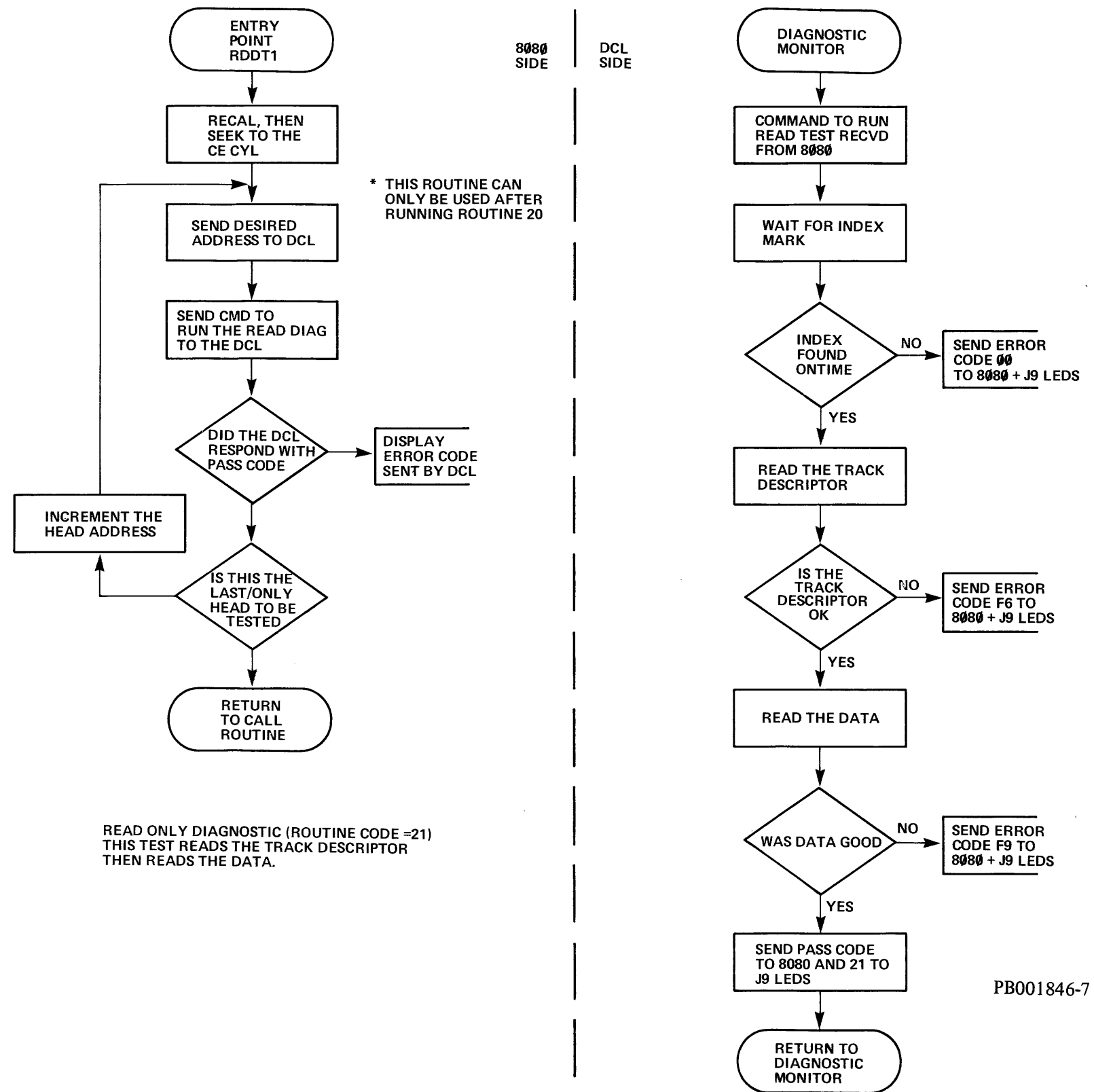
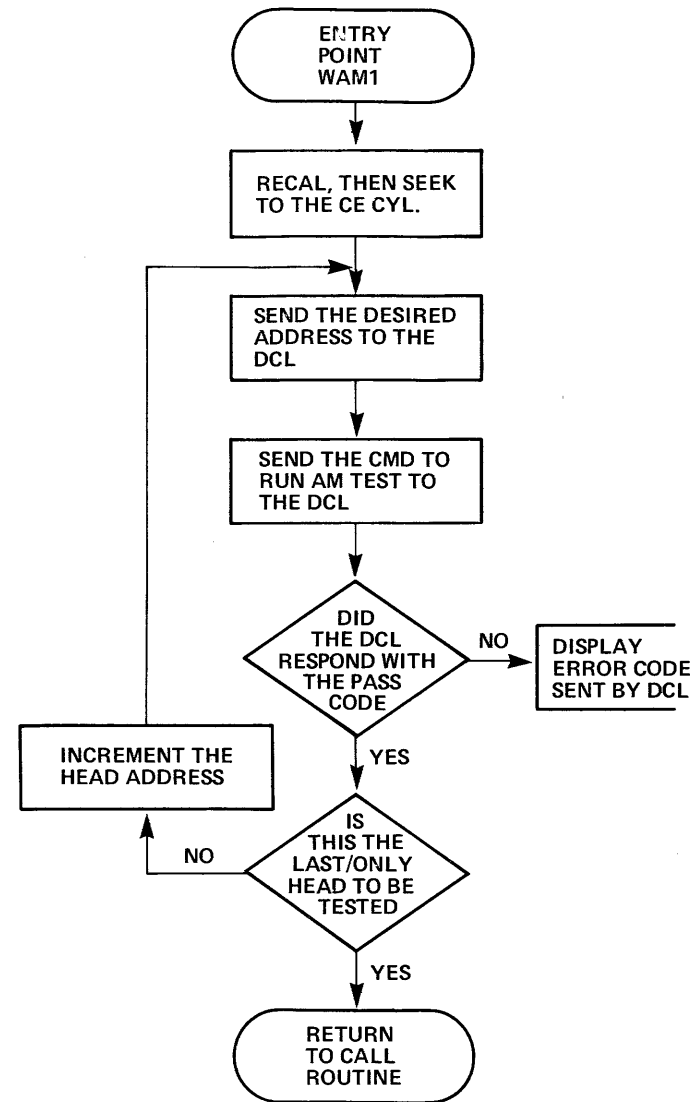
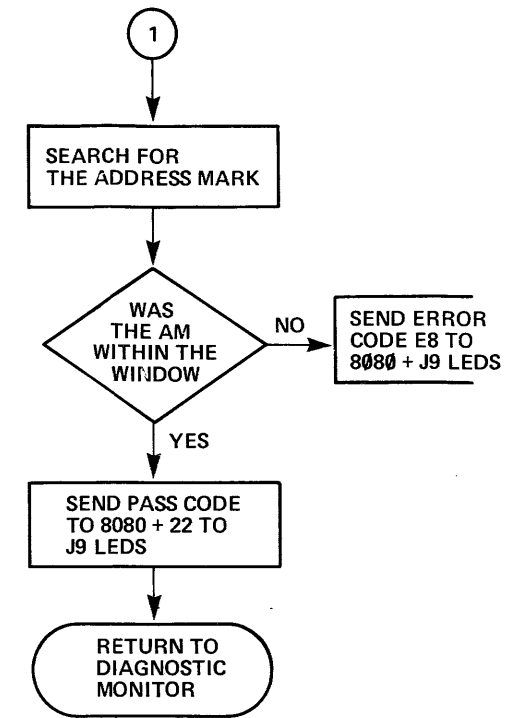
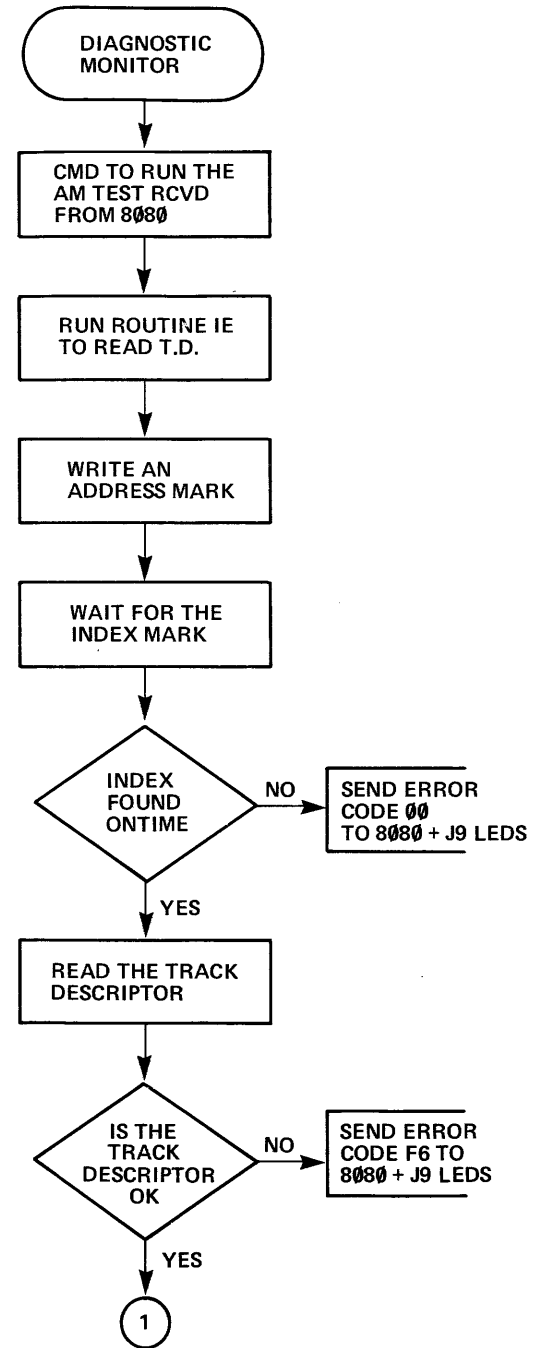

Figure 3-6-18 Read Data (RTN 21)

ADDRESS MARK TEST (ROUTINE CODE = 22)  
 THIS TEST READS THE TRACK DESCRIPTOR,  
 WRITES AN ADDRESS MARK, READS THE TD  
 AGAIN, THEN CHECKS FOR THE A.M.



8080 SIDE | DCL SIDE



PB001846-15

Figure 3-6-19 AM Test (RTN 22)

CROM PARITY CHECK (ROUTINE CODE = 23)  
 THIS ROUTINE WILL CHECK FOR ODD  
 PARITY IN ALL CROM LOCATIONS, EXCLUDING  
 LOCATIONS 152 + 1F7 THRU 1FF.

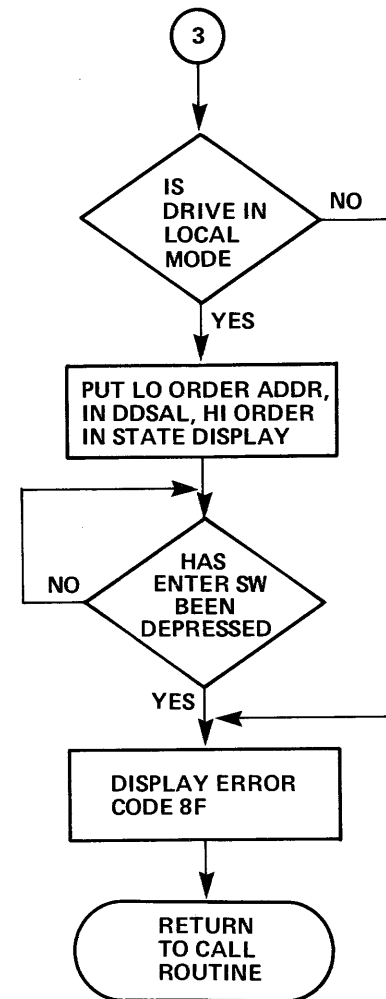
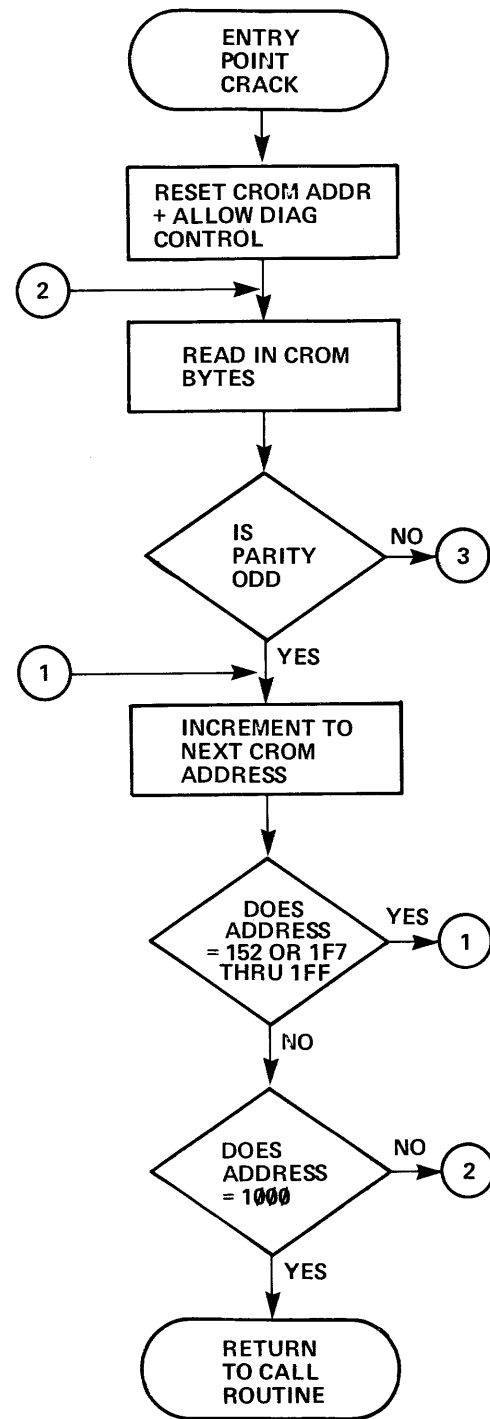

PB001846-2

Figure 3-6-20 CROM Parity DCL Check (RTN 23)

PROM CHECK ROUTINE (ROUTINE CODE = 24)  
 THIS ROUTINE TESTS EACH PROM ON THE CPU  
 CARD BY SUMMING EVERY LOCATION AND  
 SHOULD EQUAL 0. IT ALSO CHECKS THE TWO  
 NEXT TO LAST LOCATIONS WHICH SHOULD  
 EQUAL ALL 1s AND ALL 0s RESPECTIVELY.

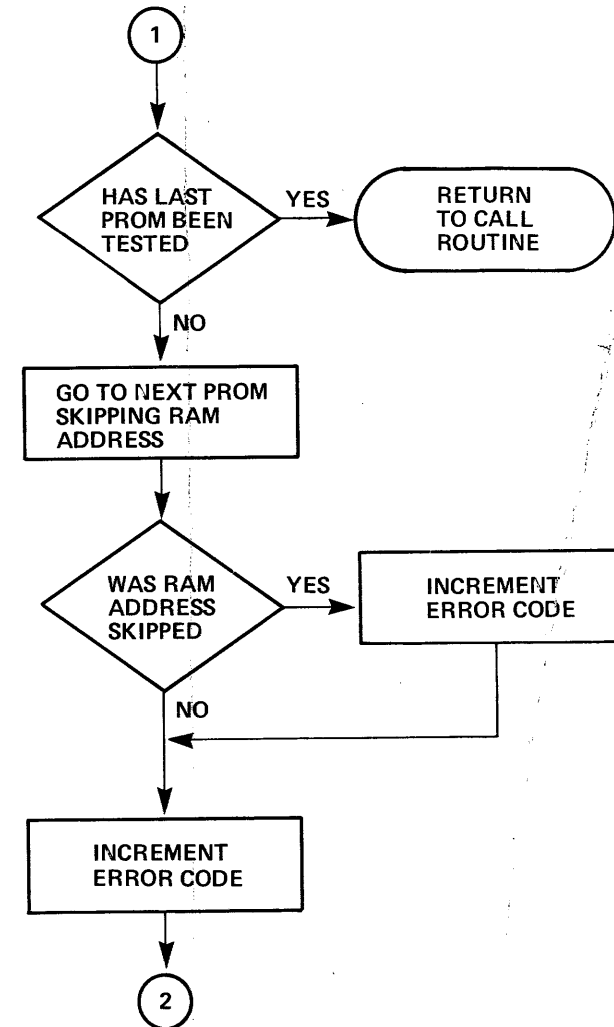
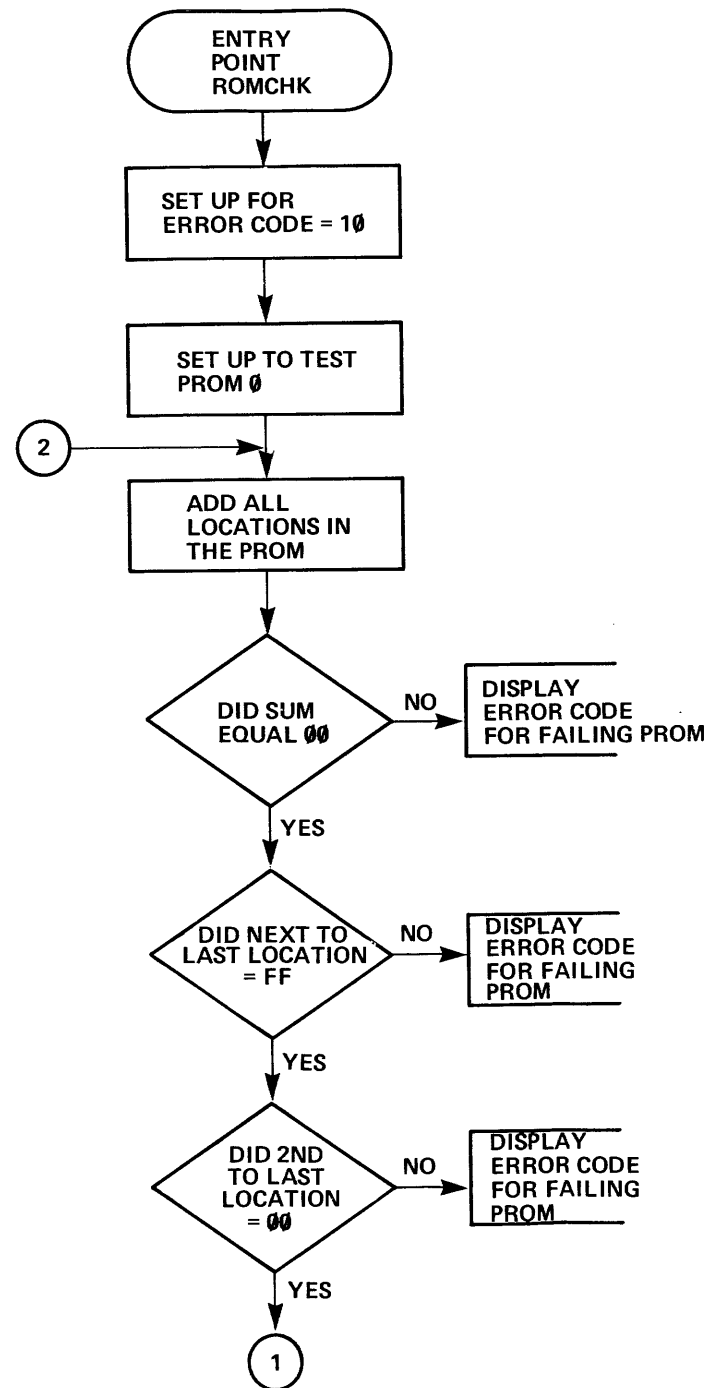

ERROR CODE LIST

10	=	PROM 0
11	=	PROM 1
12	=	PROM 2
14	=	PROM 3
15	=	PROM 4
16	=	PROM 5
17	=	PROM 6

PB001846-5

Figure 3-6-21 PROM Check (RTN 24)

REGISTER CHECK ROUTINE (ROUTINE CODE = 25)

THIS ROUTINE CHECKS THE INPUT & OUTPUT PORTS OF THE SERVO CONTROL CARD (A1A7). IT IS EXECUTED EACH TIME THE DRIVE IS INITIALIZED & CAN BE CALLED IN THE FE MODE.

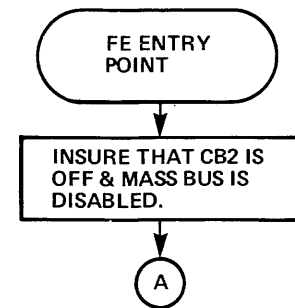
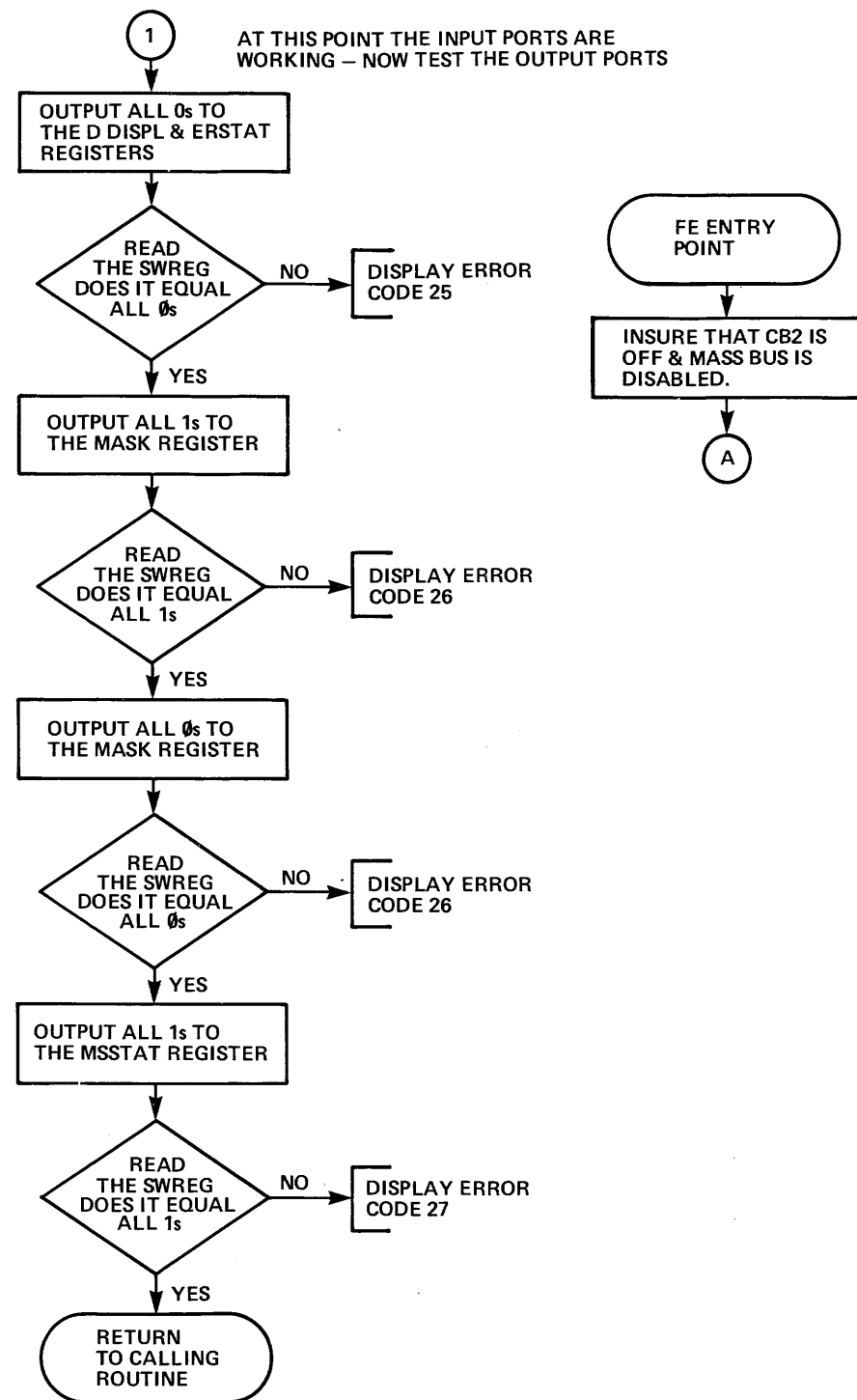
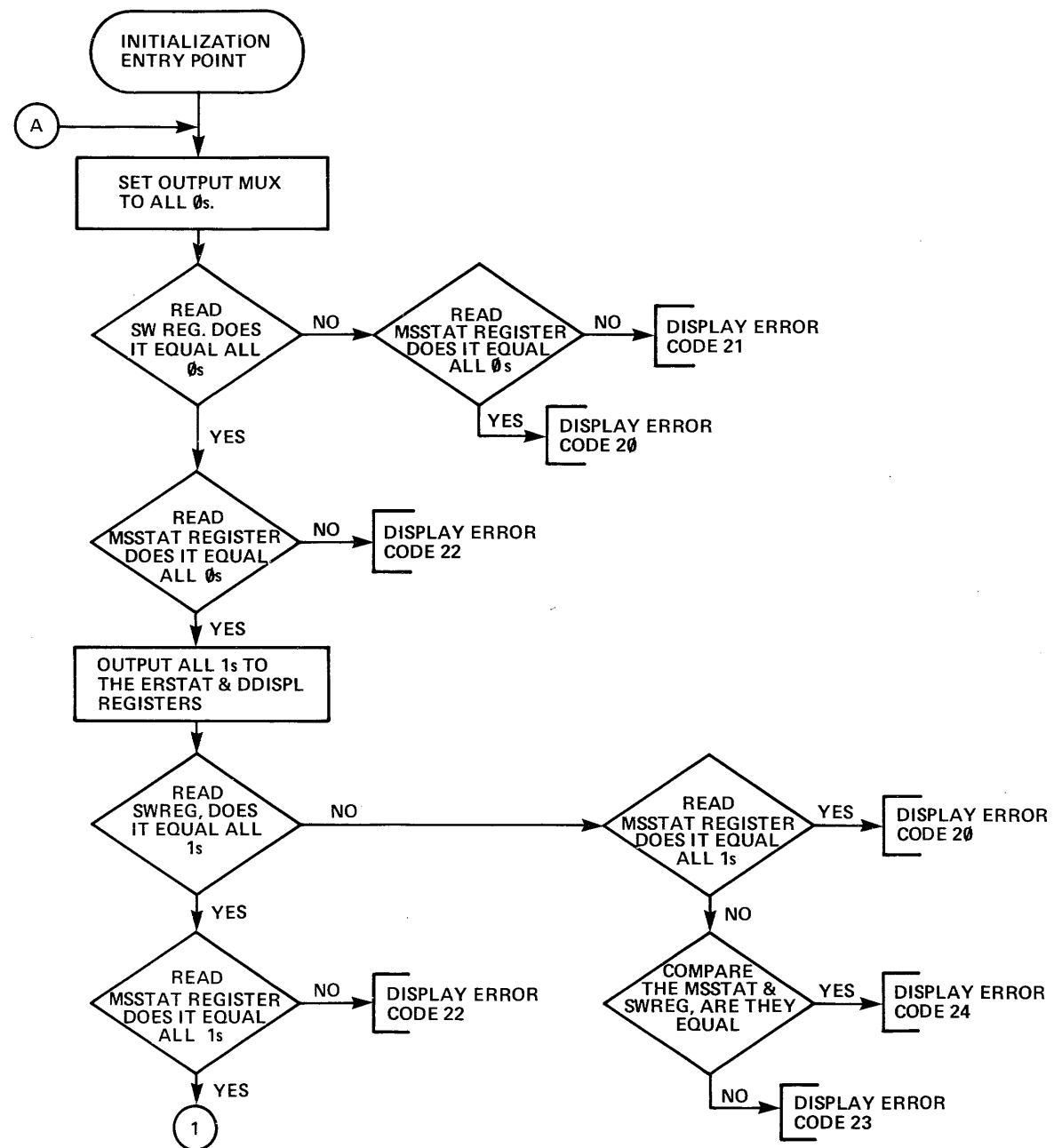

PB001837-11

Figure 3-6-22 Register Check (RTN 25)

INTERRUPT CHECK ROUTINE (ROUTINE CODE = 26)

THIS ROUTINE TESTS ALL INTERRUPT LEVELS & THEIR RESPECTIVE SERVICE ADDRESSES.

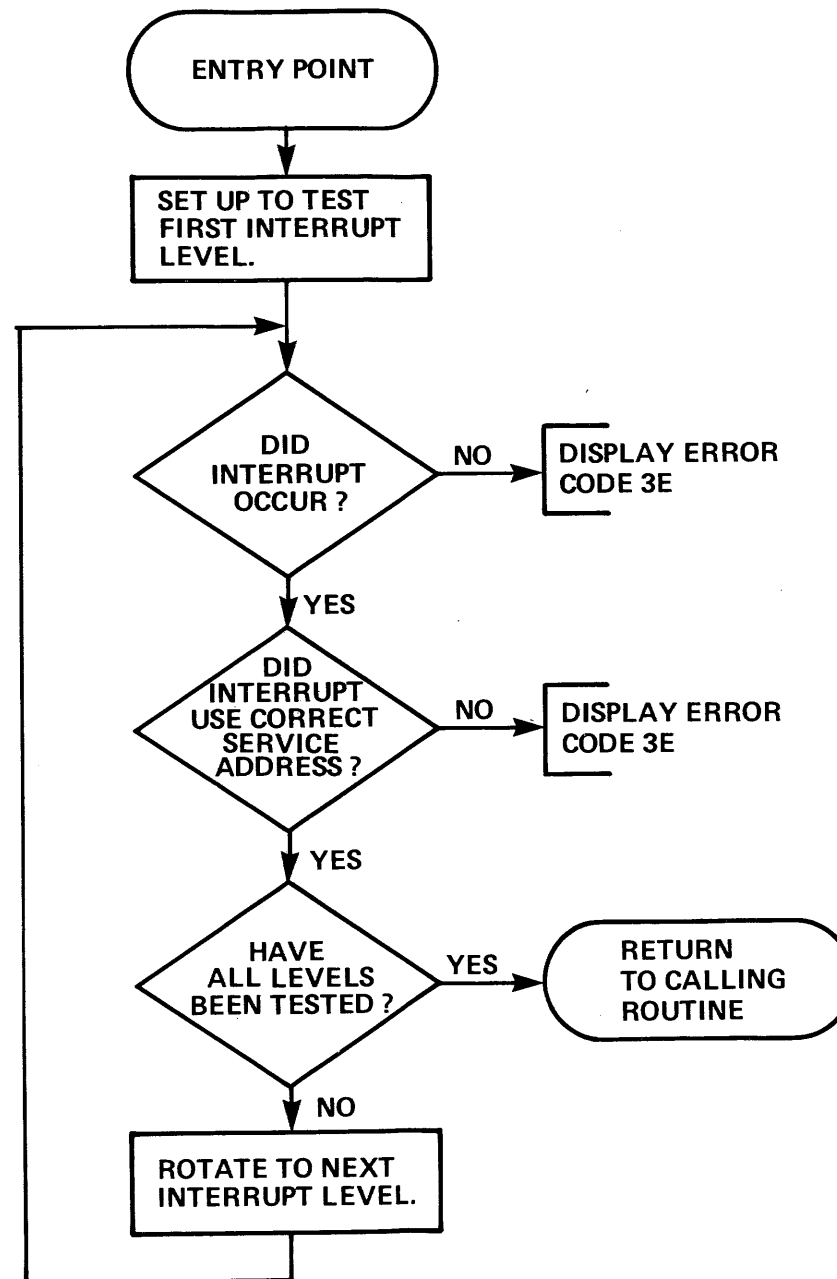

PB001837-7

Figure 3-6-23 Interrupt Check (RTN 26)

CPU UNSAFE CIRCUIT TEST ROUTINE (ROUTINE CODE = 27)  
THIS ROUTINE CHECKS THE FUNCTIONING OF THE CPU  
UNSAFE CIRCUIT.

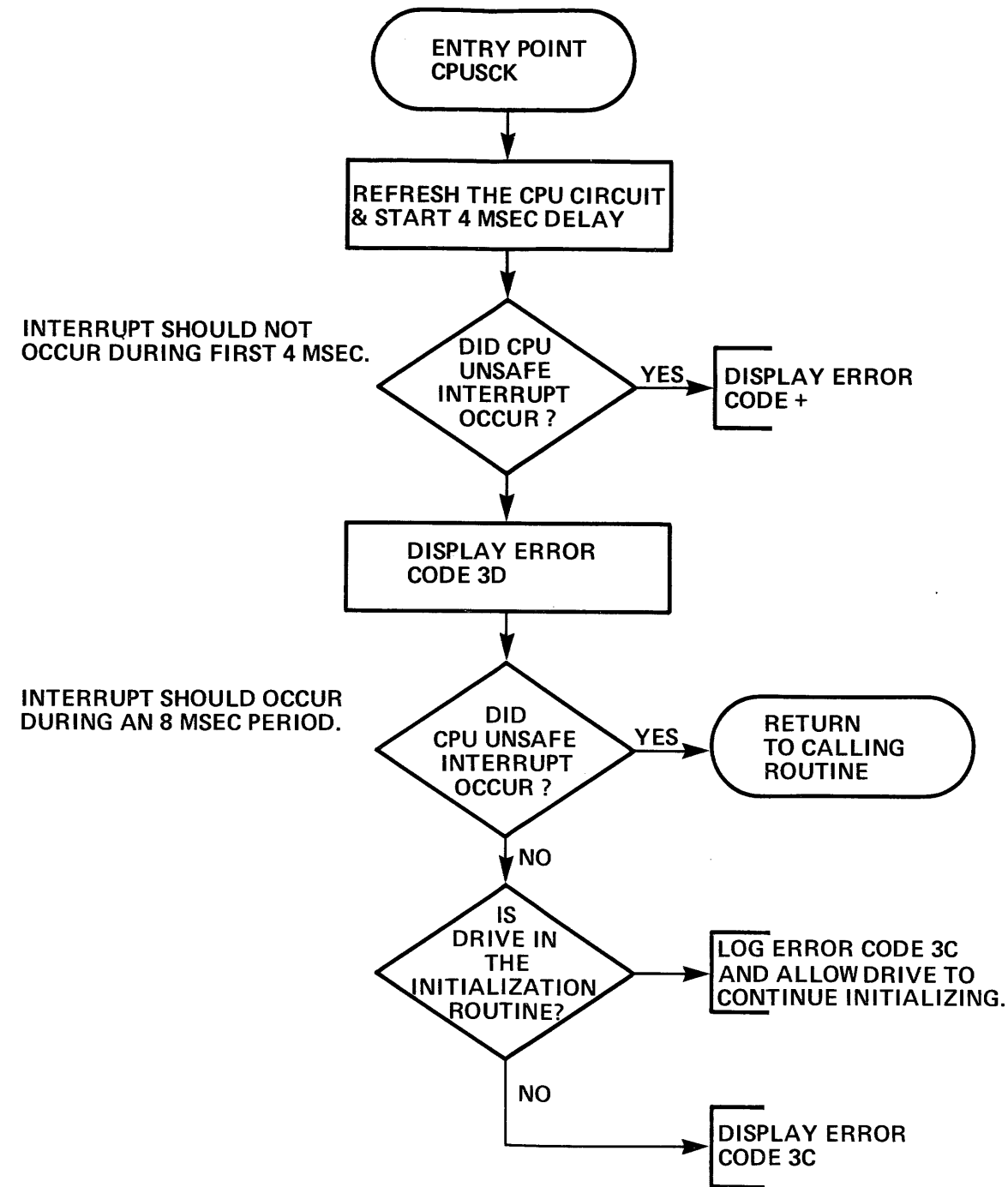

PB001838-19

Figure 3-6-24 CPU Unsafe (RTN 27)



TIMER TEST ROUTINE (ROUTINE CODE = 28)  
THIS TEST IS FOR CHECKING THE 3 TIMERS,  
LOCATED ON A1A7, TO INSURE THEY ARE  
WIHTIN SET LIMITS.

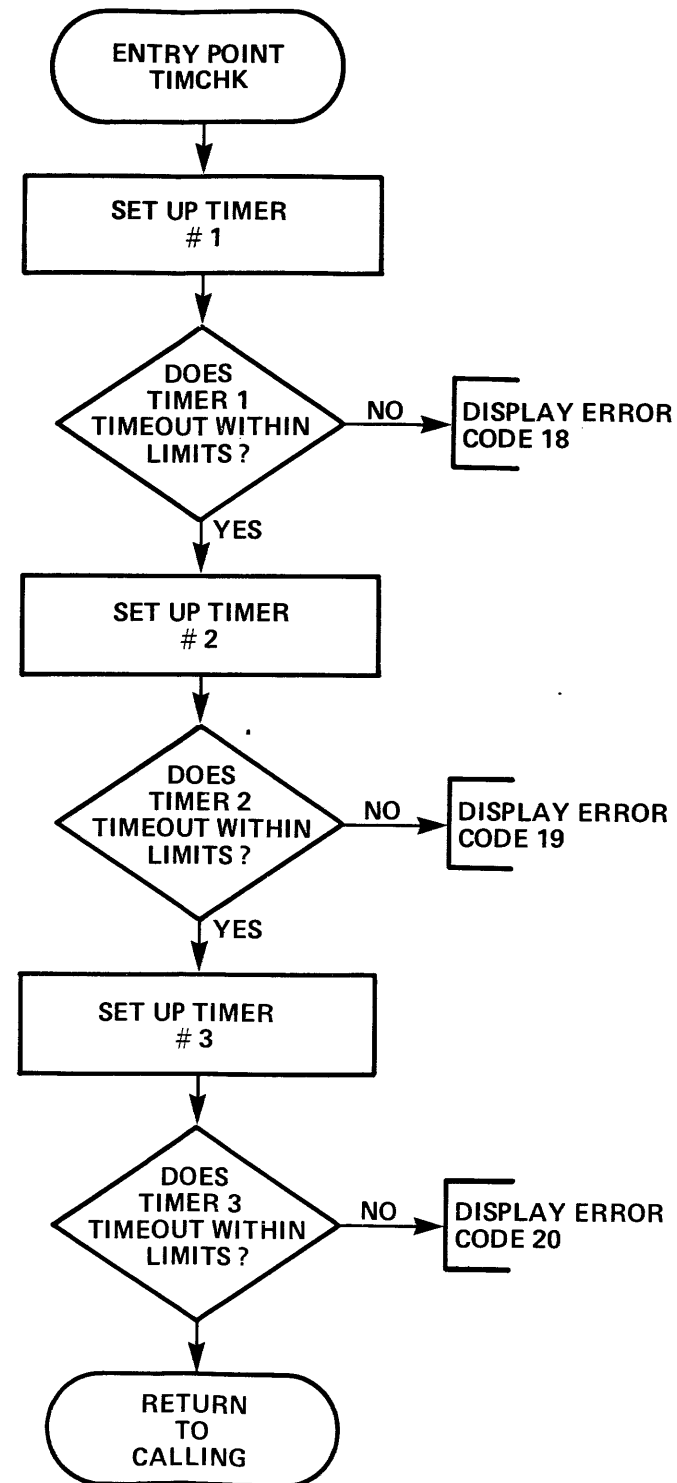

PB001837-20

Figure 3-6-25 Timer Test (RTN 28)

BUS CHECK ROUTINE (ROUTINE CODE = 29)  
 THIS ROUTINE TESTS THE BUS BY WRITING TO THE DIFF. COUNTER & THEN READING THE DATA BACK IF IT DOES NOT COMPARE IT THEN TRIES THE SAME TEST ON RAM IS THIS FAILS THE TEST FAILS.

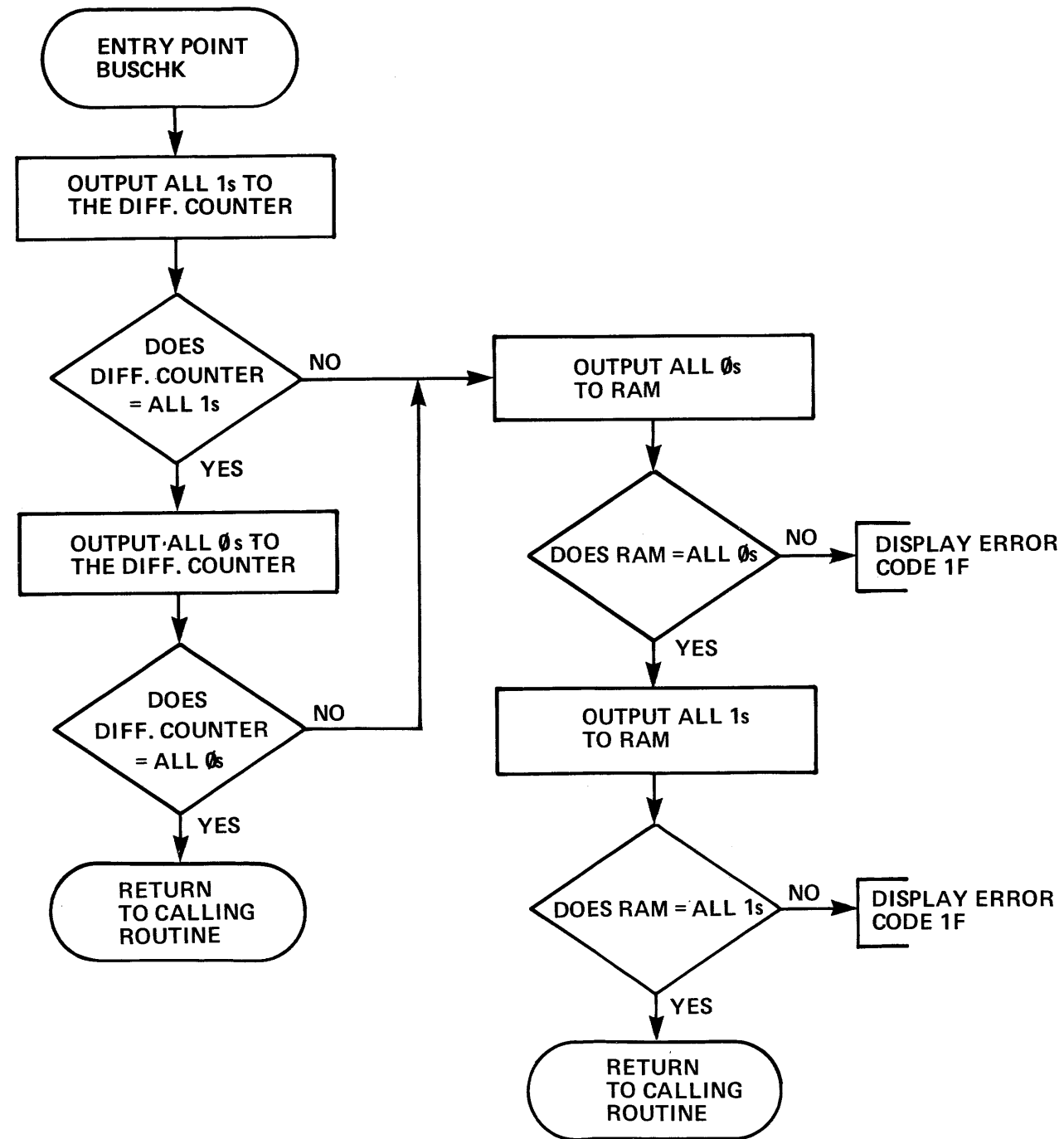

PB001837-26

Figure 3-6-26 Bus Check (RTN 29)

ANALOG "C" STATIC DIAGNOSTIC (ROUTINE = 2A)  
 THIS TEST WILL CHECK ALL BITS IN ALL RAM  
 LOCATIONS ON A1A4.

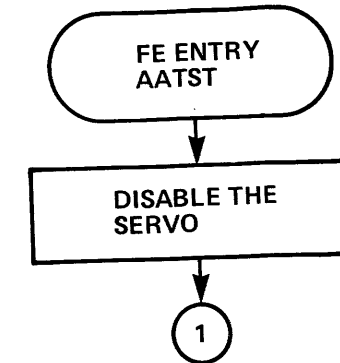
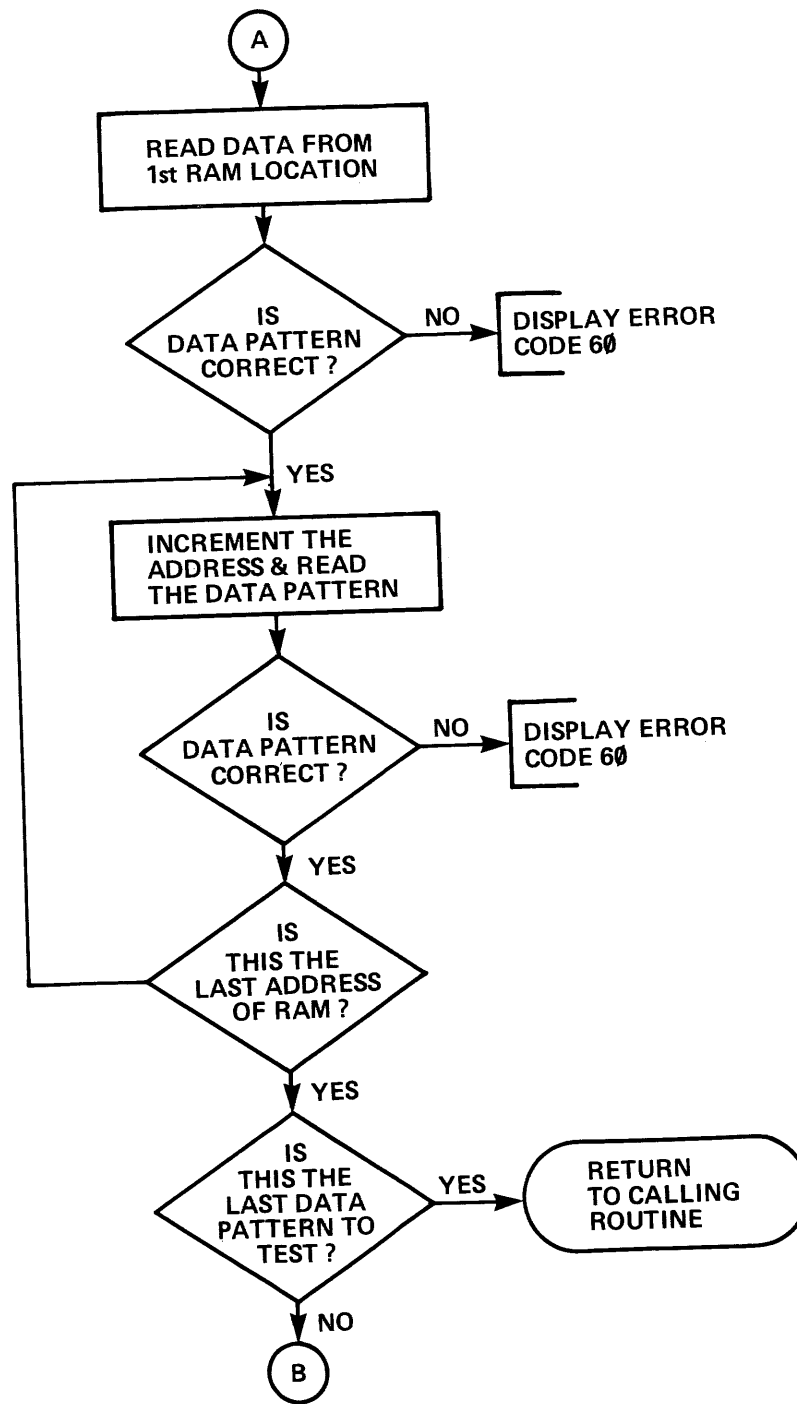
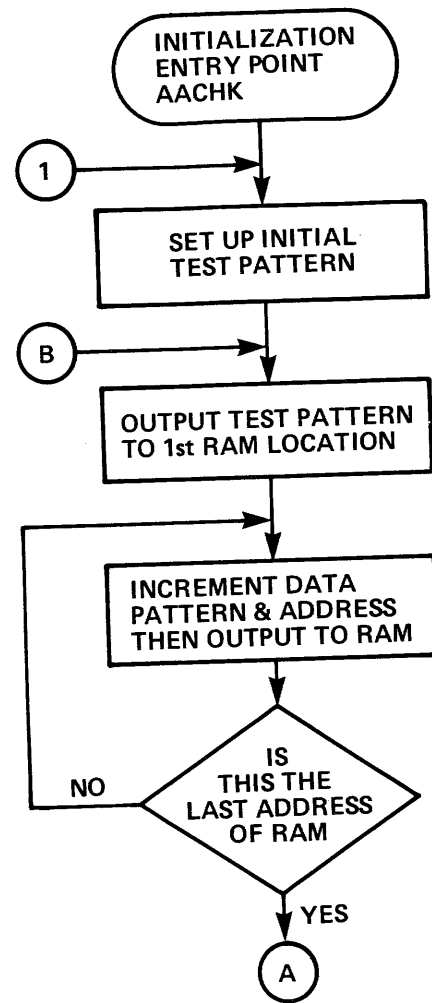

PB001837-3

Figure 3-6-27 Analog C (RTN 2A)

A/D CONVERSION TEST (ROUTINE = 2B)  
 THIS TEST WILL ZERO THE A/D CONVERTER  
 ON A1A4 THEN TEST THE UPPER AND  
 LOWER LIMITS.

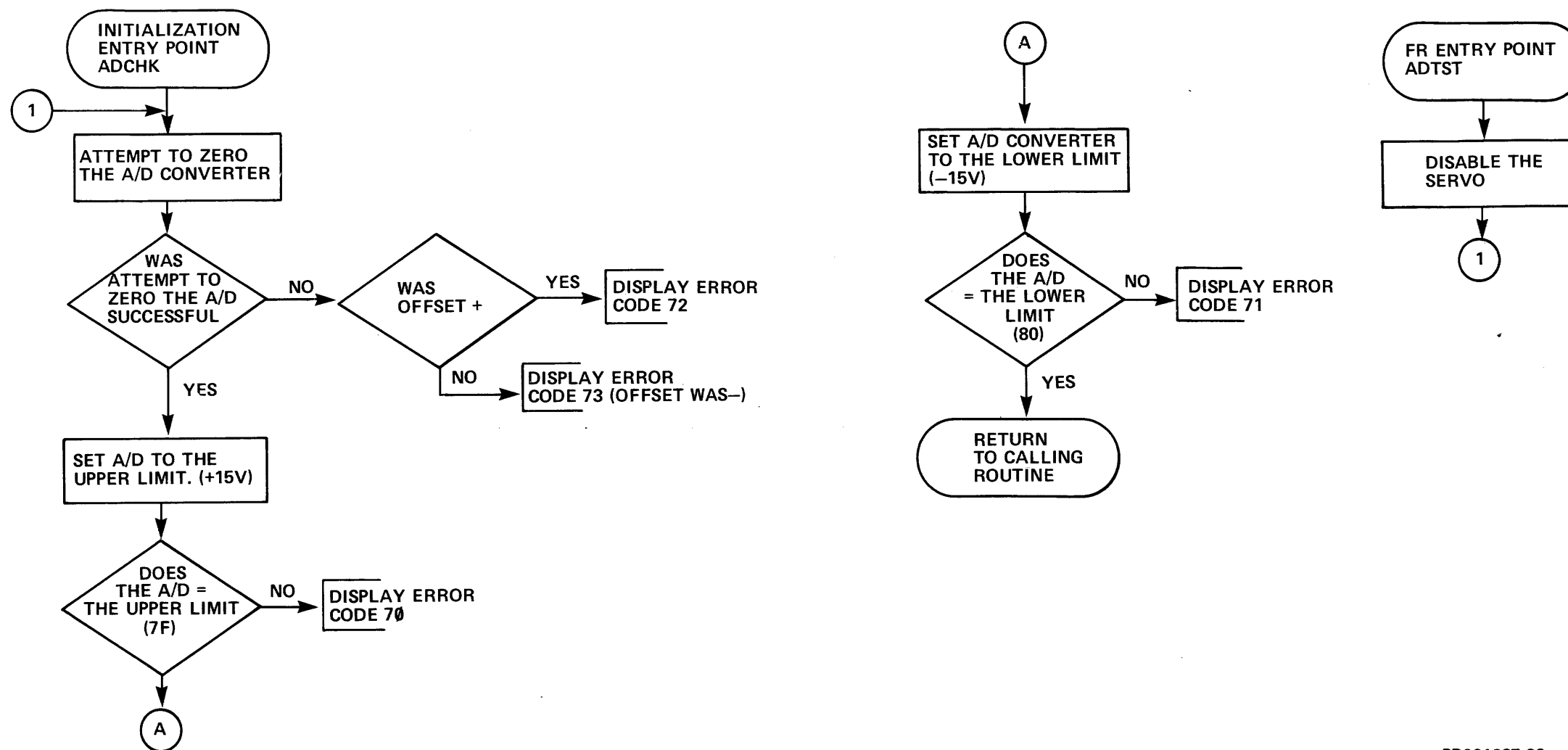

PB001837-23

Figure 3-6-28 A/D Test (RTN 2B)

A/D D/A CONVERSION TEST (ROUTINE = 2C)

THIS ROUTINE IS TESTING THE A/D & D/A LOGIC ON A1A4. THIS IS DONE BY LOADING THE D/A WITH A SPECIFIC TEST VALUE THEN WRAPPING THE CHANNEL BACK VIA THE A/D & TESTING THE VALUE.

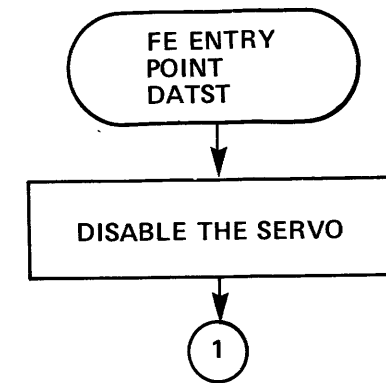
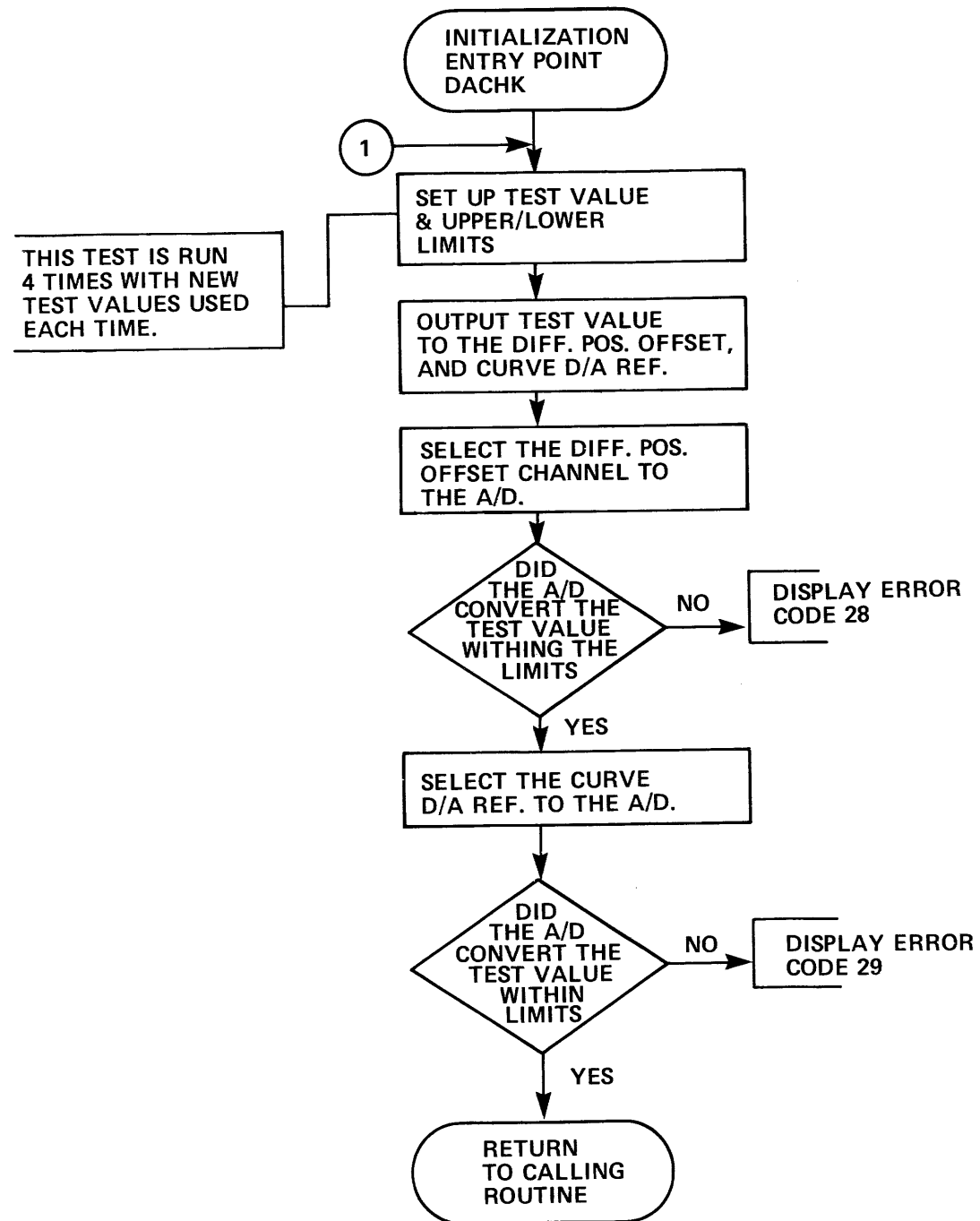

PB001837-22

Figure 3-6-29 A/D-D/A Test (RTN 2C)

ANALOG "A" OSCILLATOR TEST (ROUTINE CODE = 2D)

THIS TEST WILL ATTEMPT TO ZERO THE DIFF POSITION OFFSET AND INSURE THAT IT IS WITHIN LIMITS. THE AGC REF. IS THEN TESTED FOR PROPER GAIN.

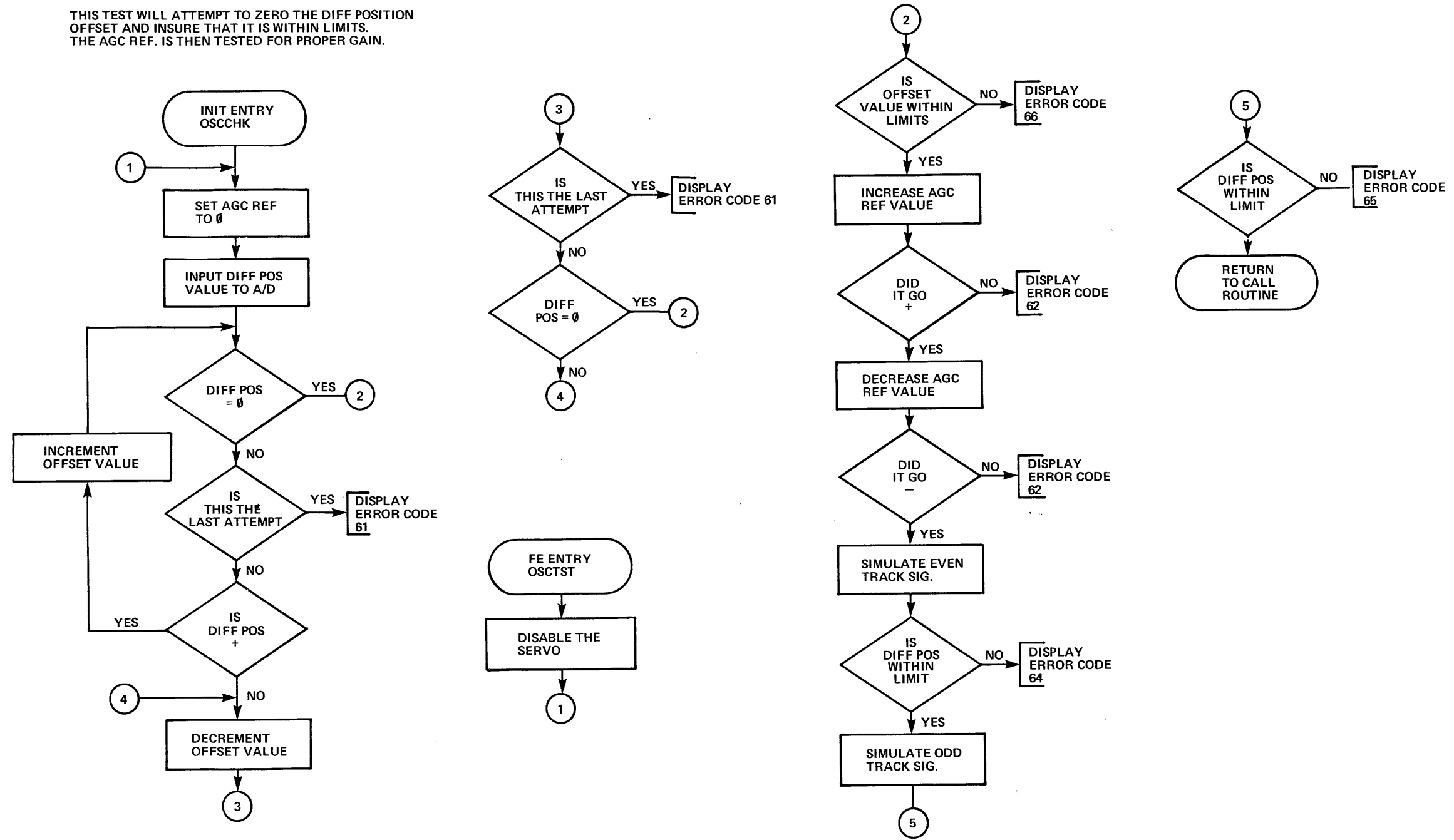

PB001837-10.

Figure 3-6-30 Oscillator Test (RTN 2D)

DIFFERENCE COUNTER TEST (ROUTINE = 2E)

THIS ROUTINE TESTS THE DIFFERENCE COUNTER BY ROTATING A TEST PATTERN. THE DIFFERENCE COUNTER CLOCK IS ALSO TESTED.

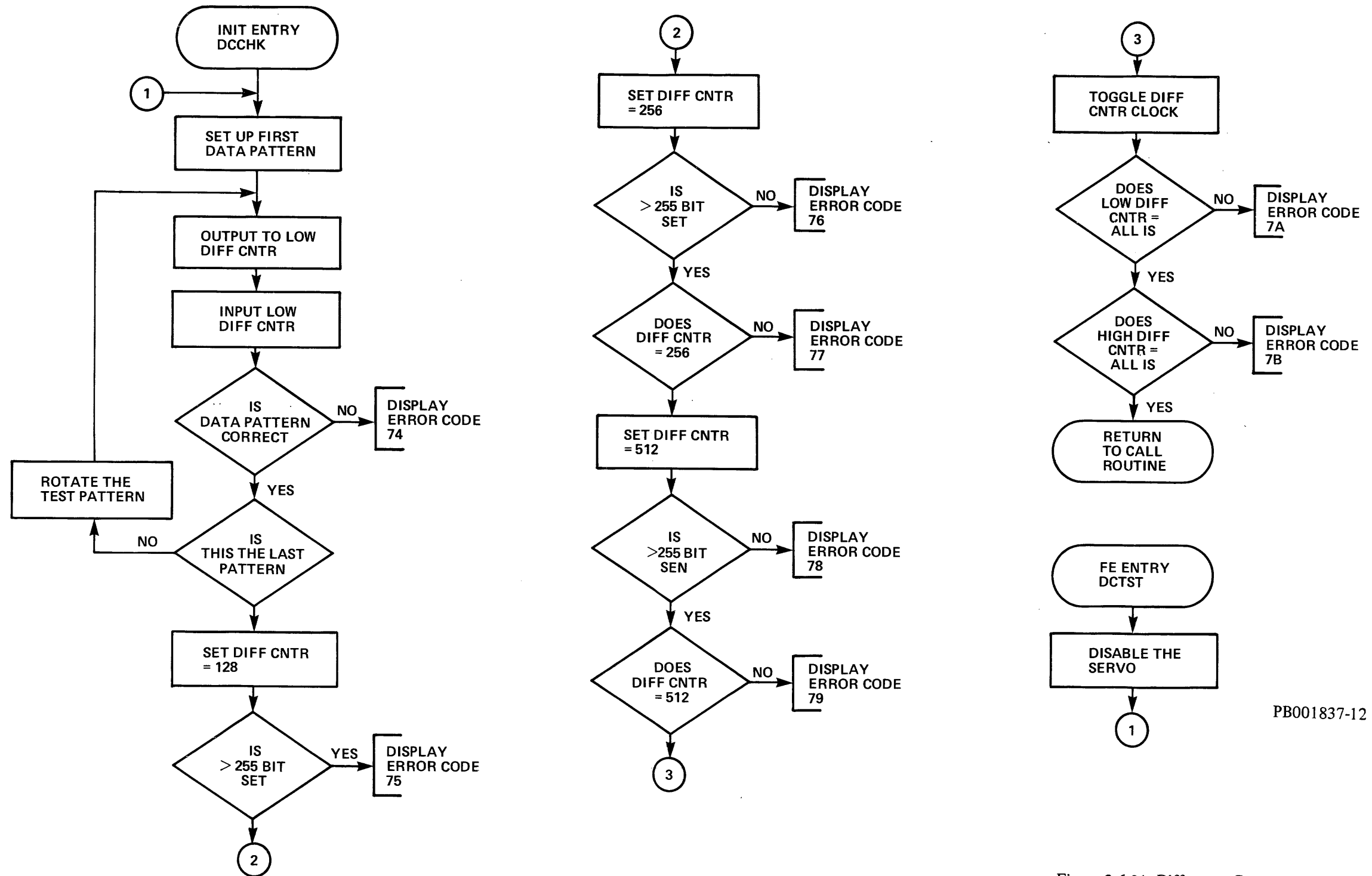
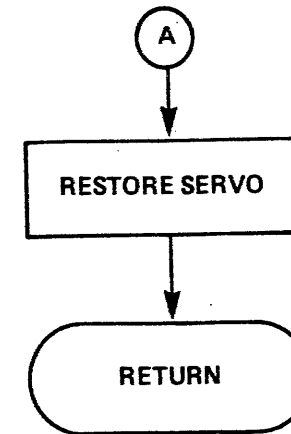
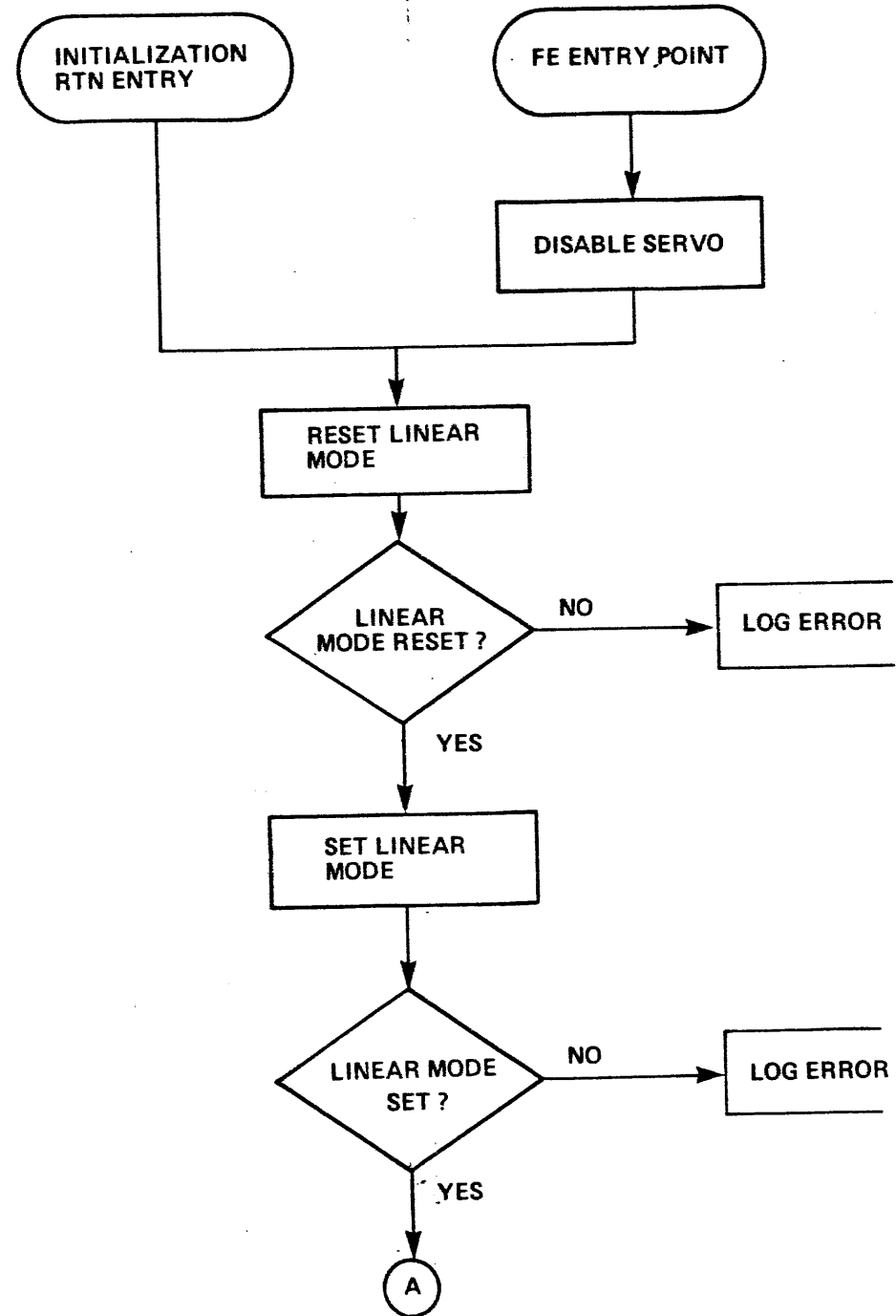

Figure 3-6-31 Difference Counter (RTN 2E)

LINEAR MODE TEST – STATUS REGISTER TEST (ROUTINE CODE = 2F)

THIS ROUTINE CHECKS THE LINEAR MODE STATUS. THIS IS DONE BY CLEARING LINEAR MODE AND THEN CHECKING TO SEE IF THE LINEAR IS LOW. THEN LINEAR MODE IS SET AND VERIFIED.



PB001837-28

Figure 3-6-32 Linear Mode (RTN 2F)



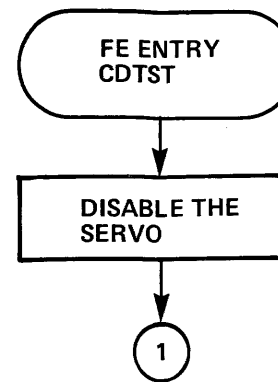
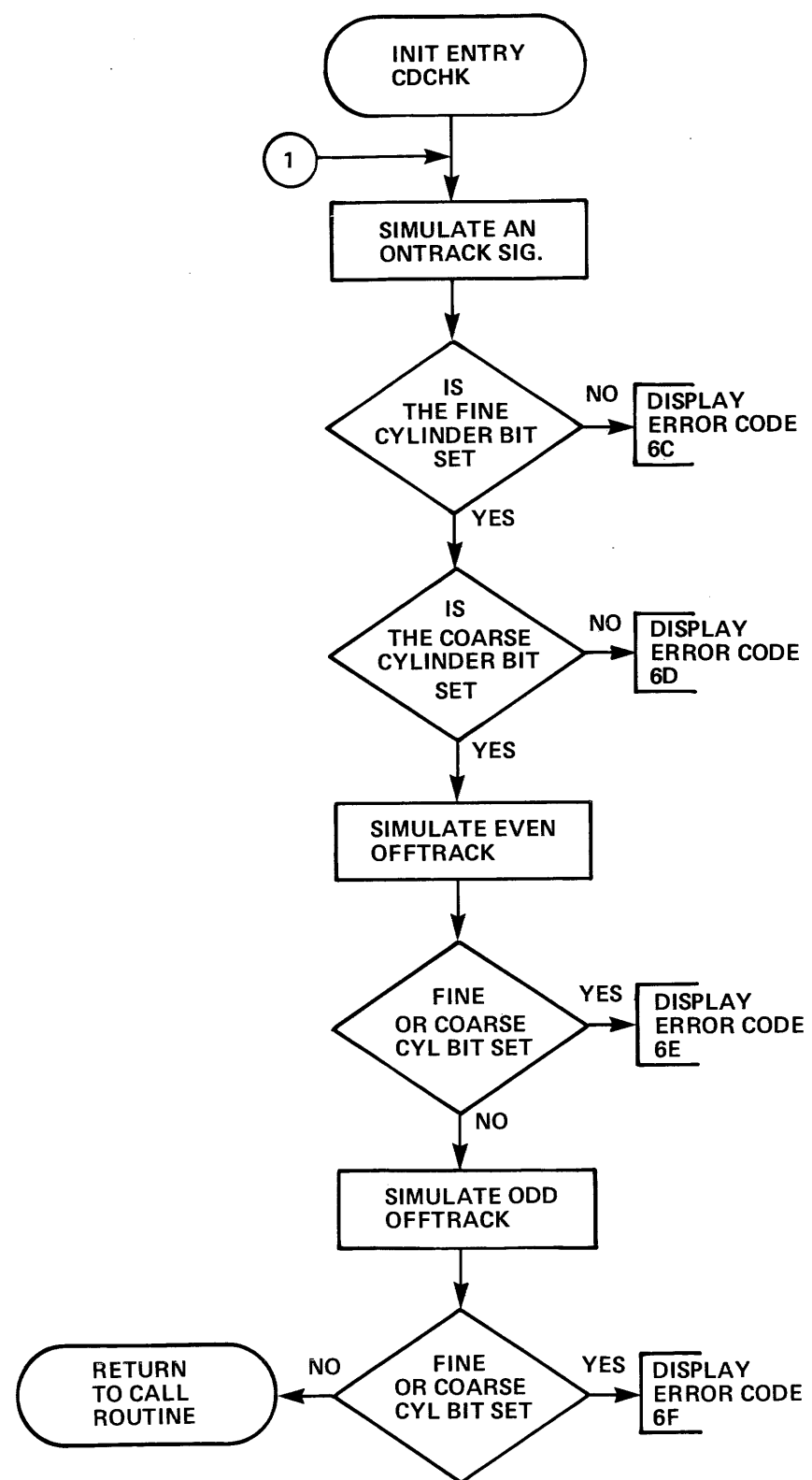

CYLINDER DETECTOR TEST – ANALOG B (ROUTINE CODE = 30)  
 THIS TEST CHECKS THE FINE AND COARSE CYLINDER DETECTORS.

PB001837-17

Figure 3-6-33 Cylinder Detector (RTN 30)

POSITION CHANNEL TEST – ANALOG B (ROUTINE = 31)

THIS ROUTINE CHECKS THE POSITION AND DIFF. POSITION CHANNELS.

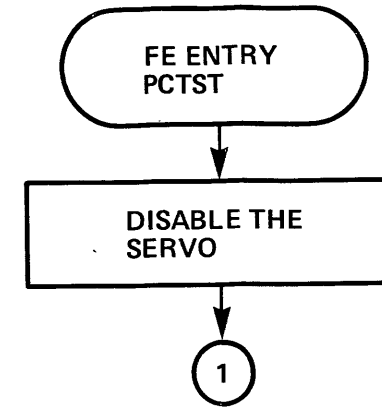
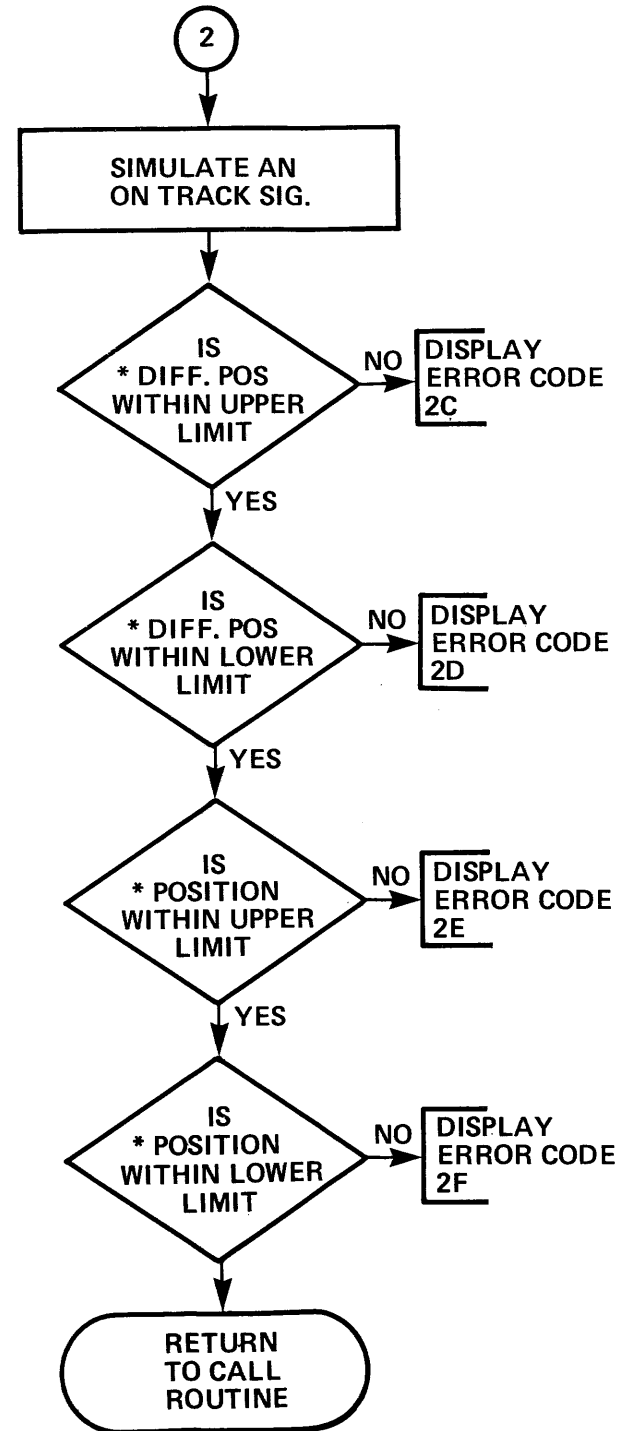
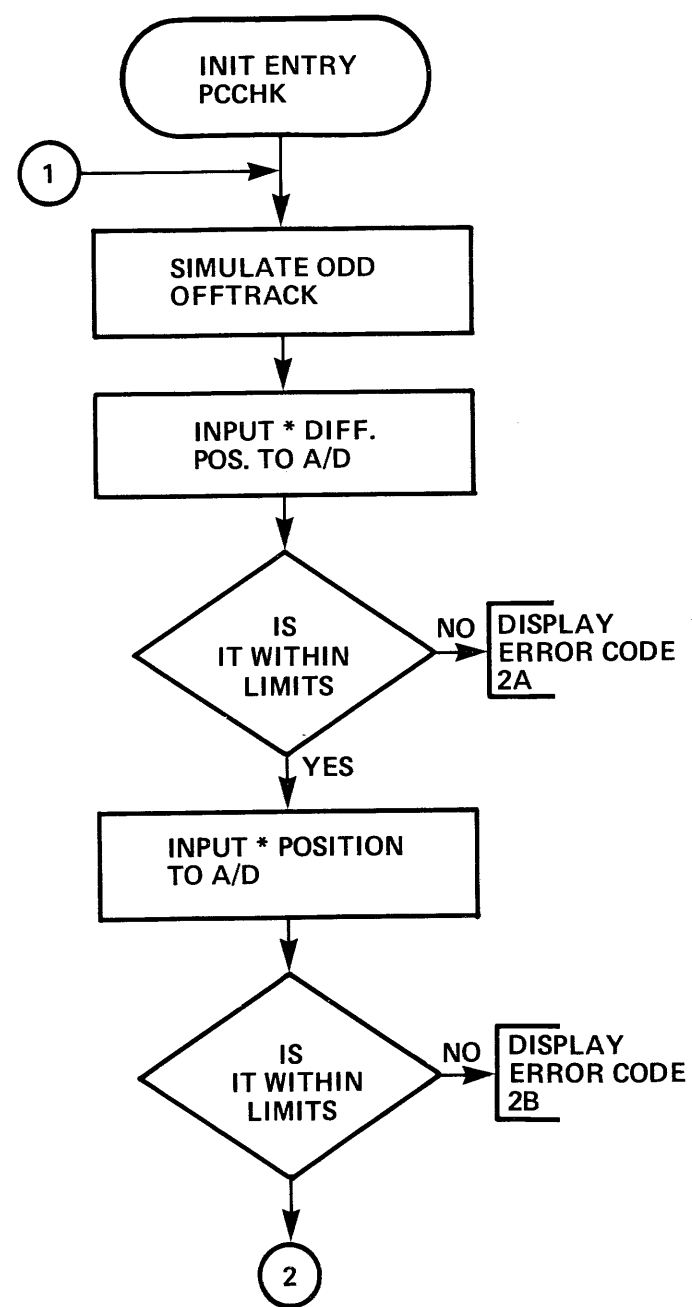

PB001837-18

Figure 3-6-34 Position Channel (RTN 31)

SERVO ERROR AMP TEST (ROUTINE CODE = 32)

THIS TEST DETERMINES IF THE SERVO ERROR AMP OFFSET IS WITHIN SPECIFIED LIMITS.

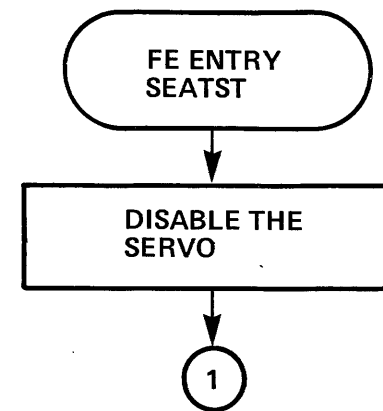
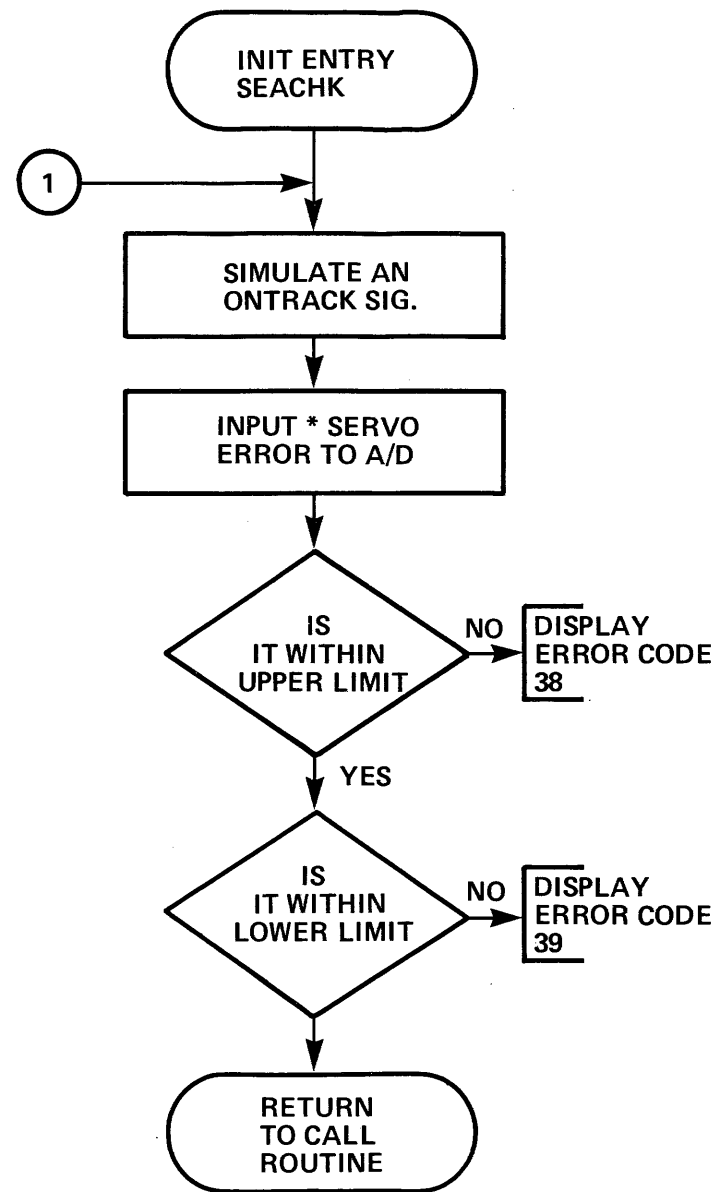

PB001837-21

Figure 3-6-35 Servo Amp (RTN 32)

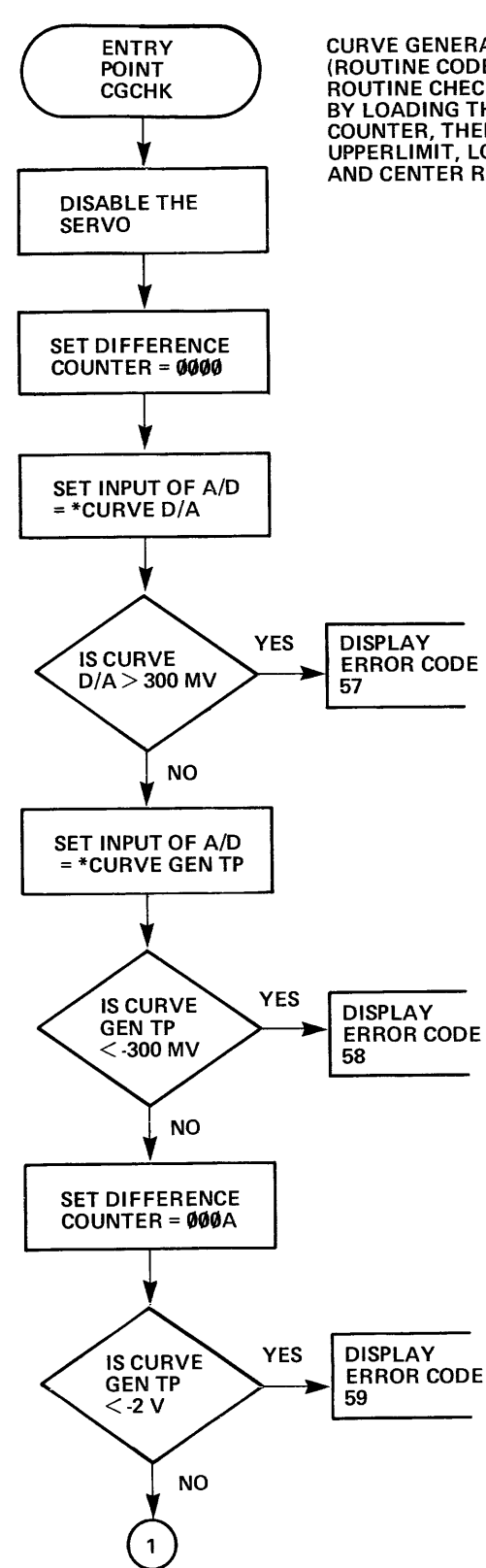

CURVE GENERATOR TEST (ROUTINE CODE = 33) THIS ROUTINE CHECKS THE CURVE BY LOADING THE DIFFERENCE COUNTER, THEN CHECKS THE UPPERLIMIT, LOWERLIMIT, AND CENTER RANGES.

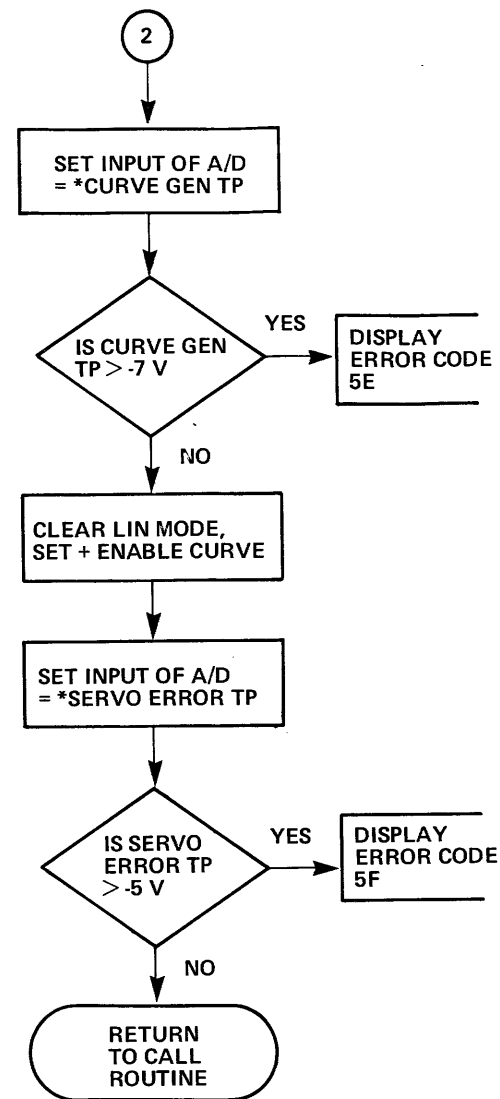
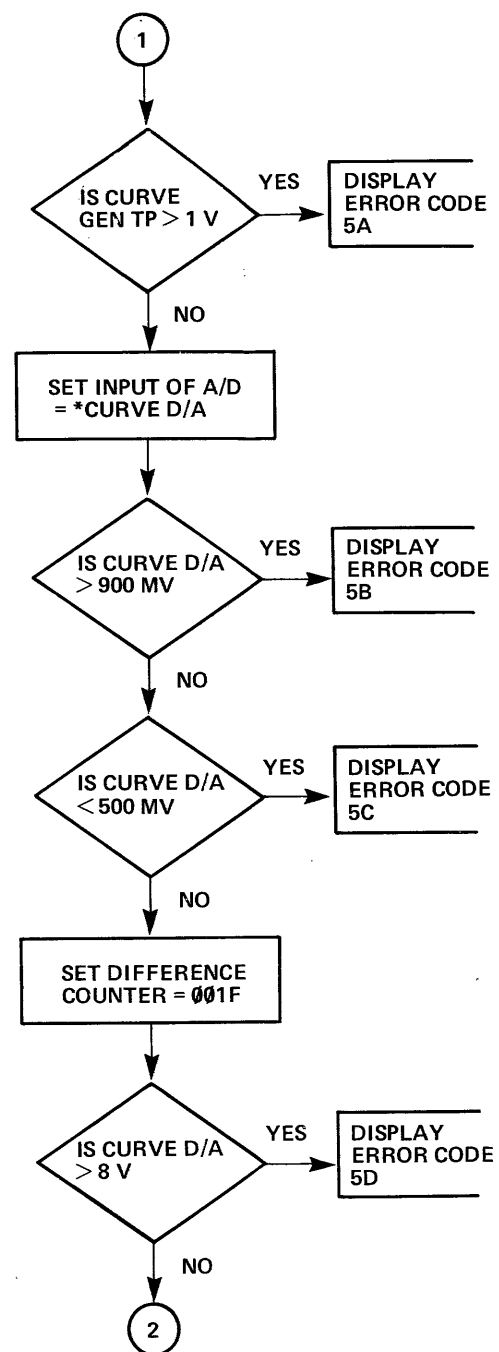

PG001846-8

Figure 3-6-36 Curve Generator (RTN 33)

COMMUNICATION/MAINTENANCE REGISTER TEST (ROUTINE CODE = 34)  
 THE REGISTERS ARE TESTED BY WRAPPING 1 BIT HIGH AT A TIME VIA  
 THEIR INPUT/OUTPUT BUS LINES.

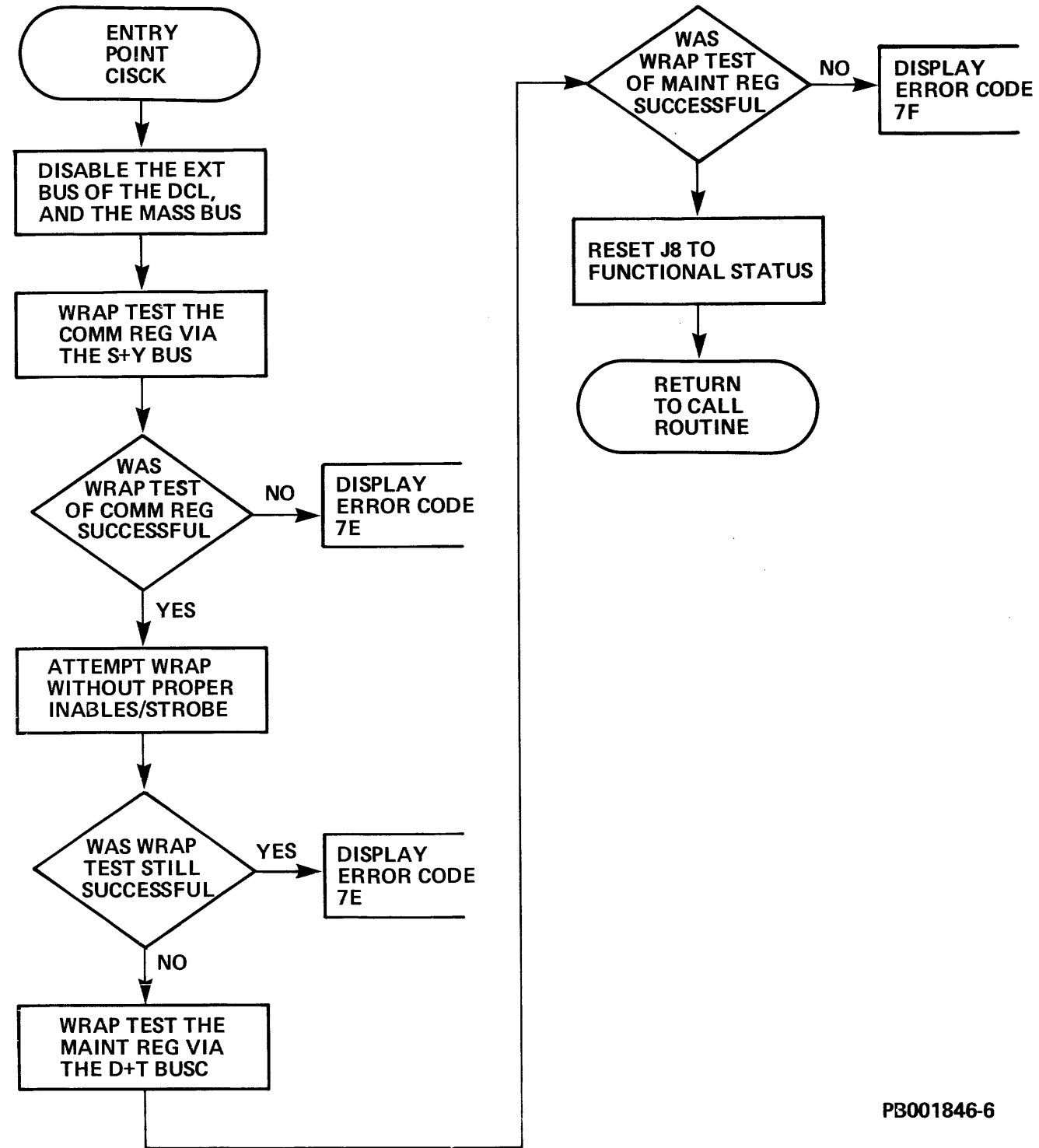

PB001846-6

Figure 3-6-37 Comm/Maint Register Test (RTN 34)

CROM CHECK ROUTINE (ROUTINE CODE = 35)

THIS ROUTINE WILL VERIFY CROM CHECK SUMS BY GENERATING A SUM ON THE DATA & COMPARING WITH PRESTORED SUMS STORED IN CROM 0. CROM 0 IS DIFFERENT IN THAT IT IS TESTED TO EQUAL 0.

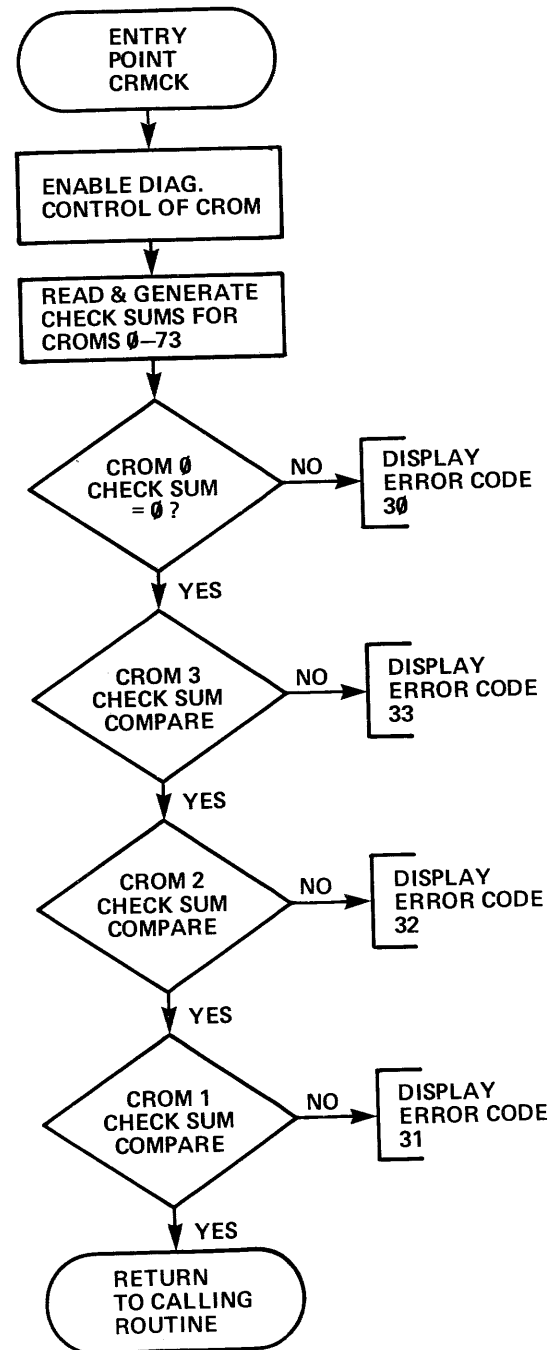

PB001837-13

Figure 3-6-38 CROM Check Sum Test (RTN 35)

DCL 1 CHECK ROUTINE (ROUTINE CODE = 36)  
 THIS ROUTINE WILL HOLD THE 2901 AT LOCATION  
 0 & RUN A WRAP TEST VIA THE COMM. REG.,  
 THEN RELEASE IT AND TEST THE DCL UNSAFE  
 BIT. IT WILL THEN SEND A NO-OP COMMAND &  
 CHECK FOR THE PROPER RESPONSE.

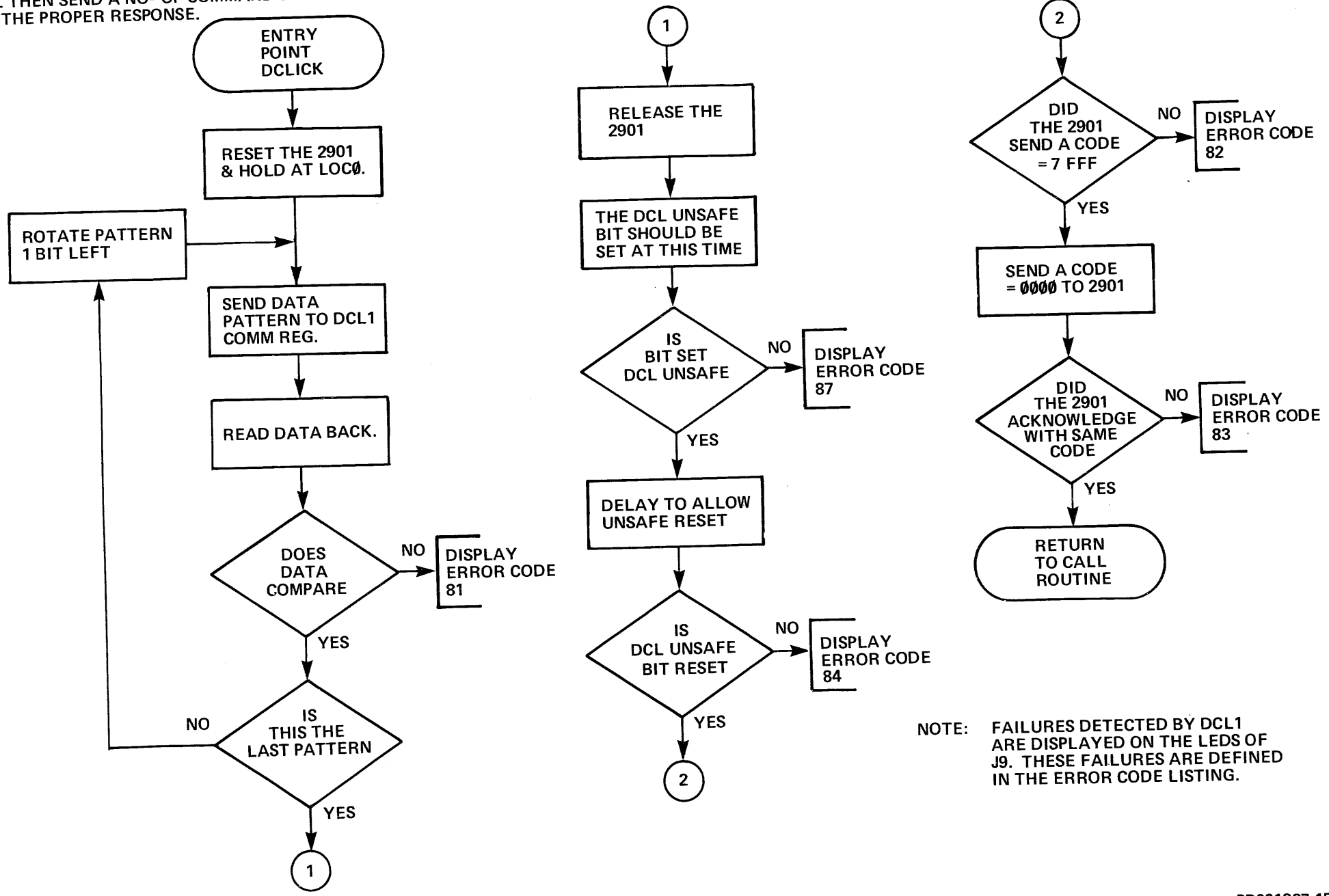

NOTE: FAILURES DETECTED BY DCL1 ARE DISPLAYED ON THE LEDS OF J9. THESE FAILURES ARE DEFINED IN THE ERROR CODE LISTING.

PB001837-15

Figure 3-6-39 DCL 1 Test (RTN 36)

DCL #2 CHECK ROUTINE (ROUTINE CODE = 37)  
 THIS ROUTINE FIRST INSURES THAT DCL #1 IS  
 FUNCTIONING THEN TESTS THE DCL #2 (J10) PCA.

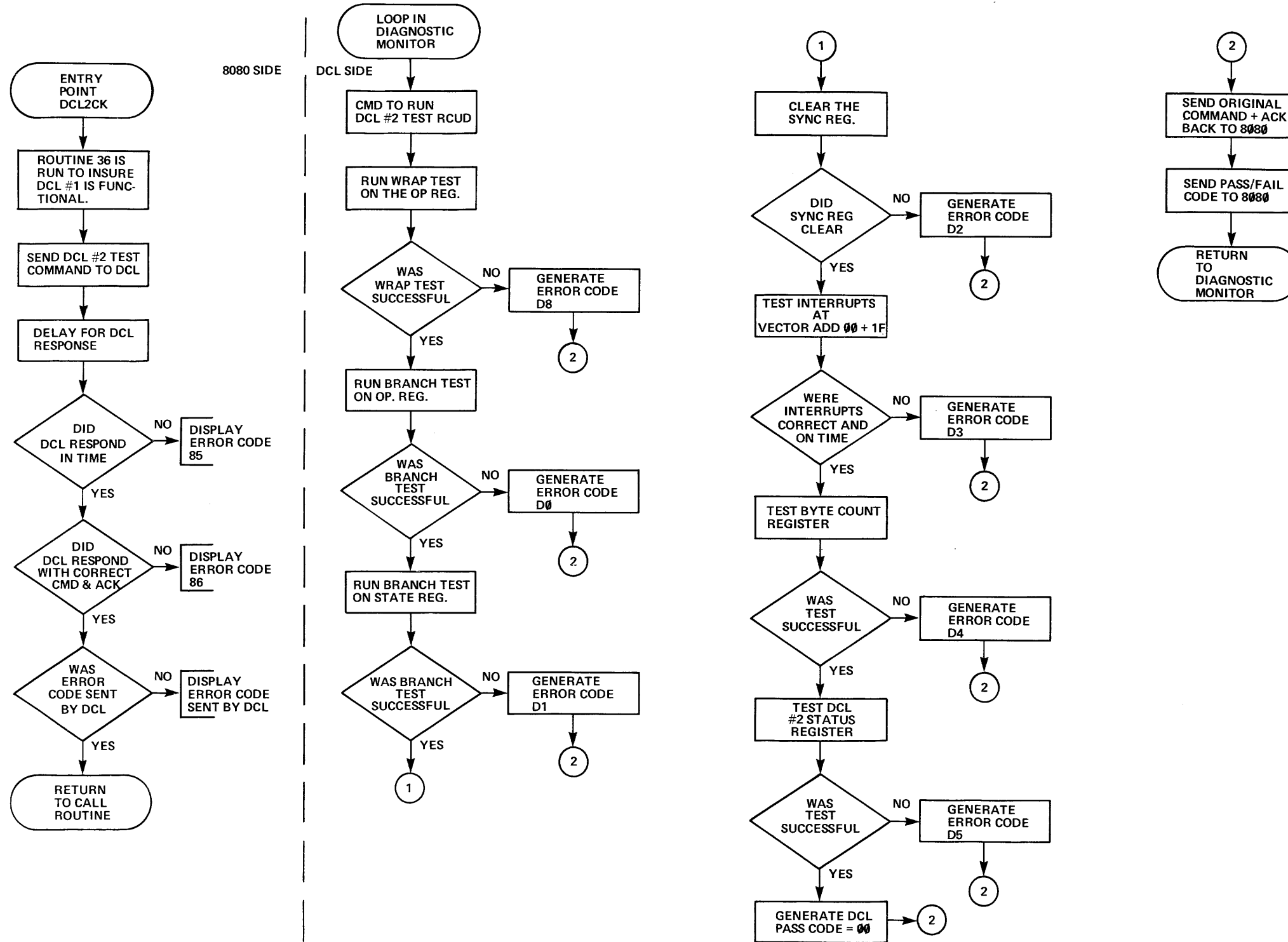

PB001837-16

Figure 3-6-40 DCL 2 Test (RTN 37)



INTERFACE CONTROL CHECK ROUTINE (ROUTINE CODE = 38)

THIS ROUTINE FUNS A WRAP CHECK ON THE FOLLOWING REGISTERS LOCATED ON PCA (J12): ECC PATTERN, ECC POSITION, ERROR 3, DESIRED ADDRESS, CURRENT CYLINDER, DESIRED CYLINDER, OFFSET, AND ERROR 1

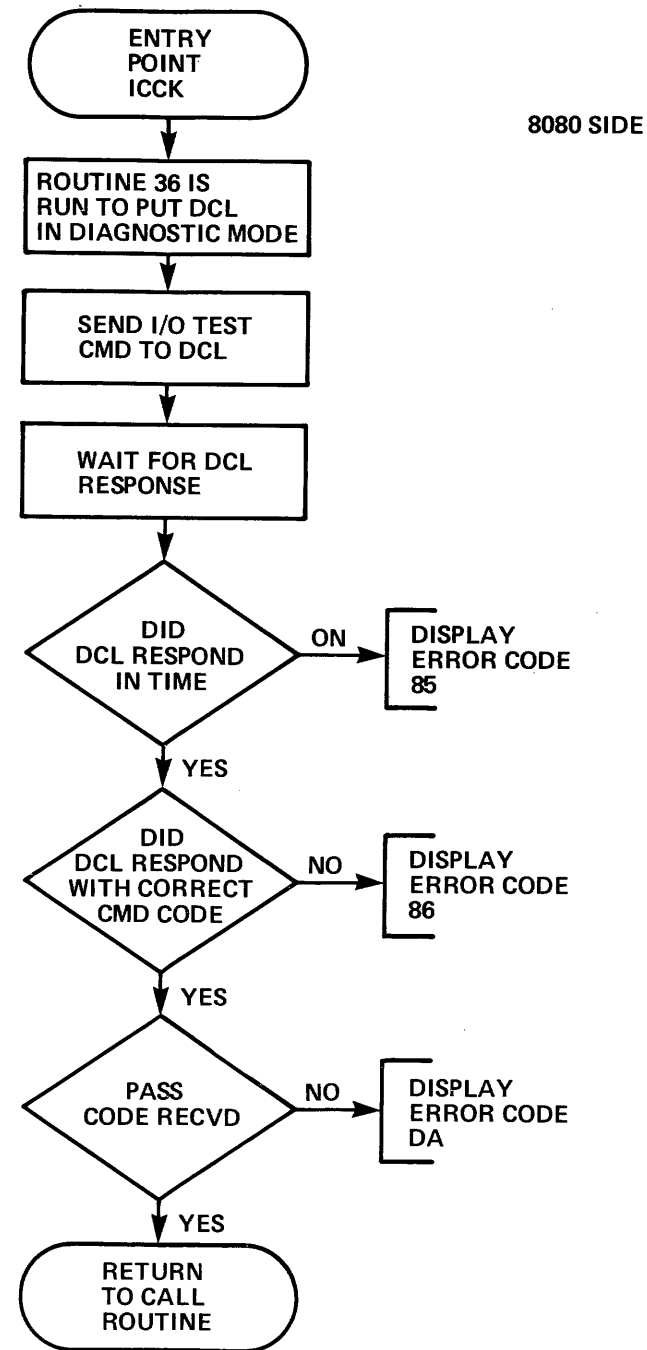

DCL SIDE

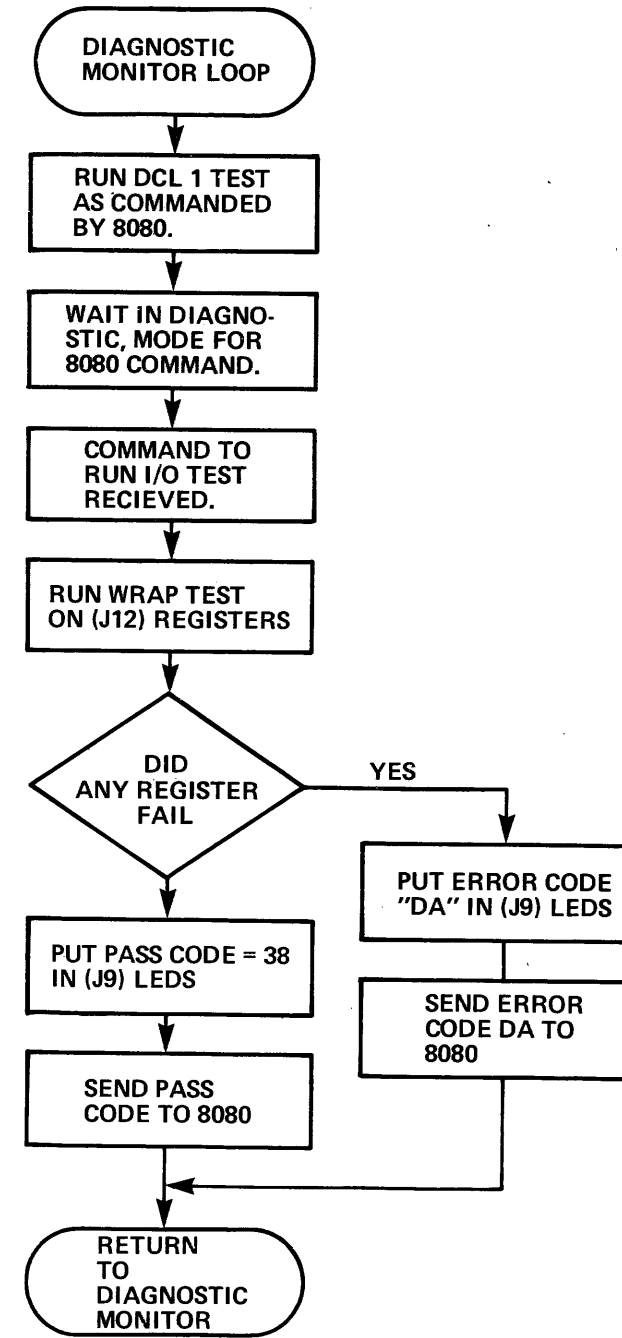

PB001837-14

Figure 3-6-41 I/O Wrap (RTN 38)

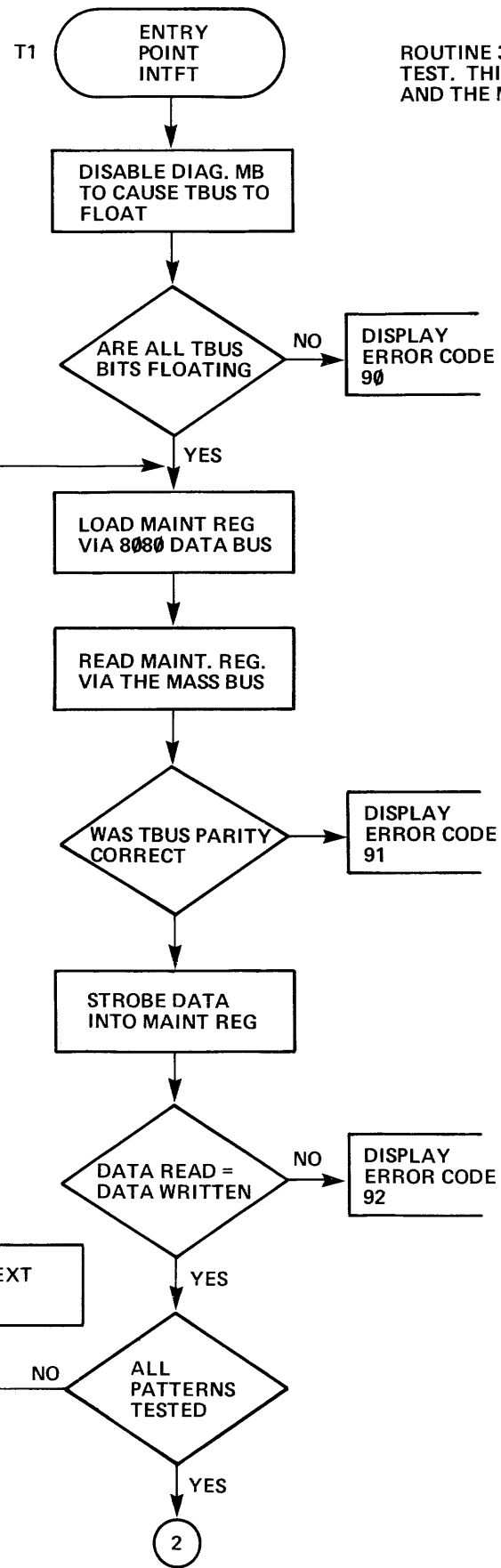

ROUTINE 39, TEST 1 – PARITY/MAIN TENACE REGISTER TEST. THIS TEST CHECKS THE TBUS PARITY CHECKER AND THE MAINTENANCE REG. ON THE TBUS.

INTERFACE TEST ROUTINE (ROUTINE CODE = 39)

THIS ROUTINE IS DIVIDED INTO 12 SEPARATE TESTS. A FLOWCHART FOR EACH TEST IS SHOWN ON THE FOLLOWING SHEETS. THESE TESTS ARE RUN IN CONSECUTIVE ORDER WHEN ROUTINE 39 IS CALLED.

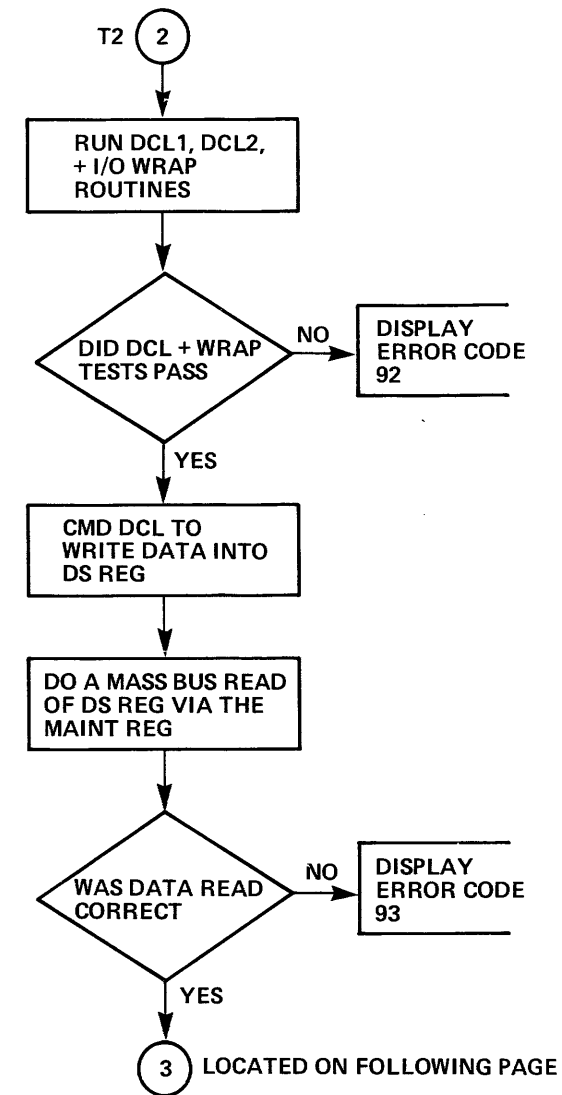

PB001846-9

ROUTINE 39, TEST 2 – THIS TEST CHECKS THE DS REGISTER BY LOADING IT VIA THE DCL, THEN READING IT VIA THE MAINTENANCE REGISTER.

Figure 3-6-42 Full Check on J12 (RTN 39)

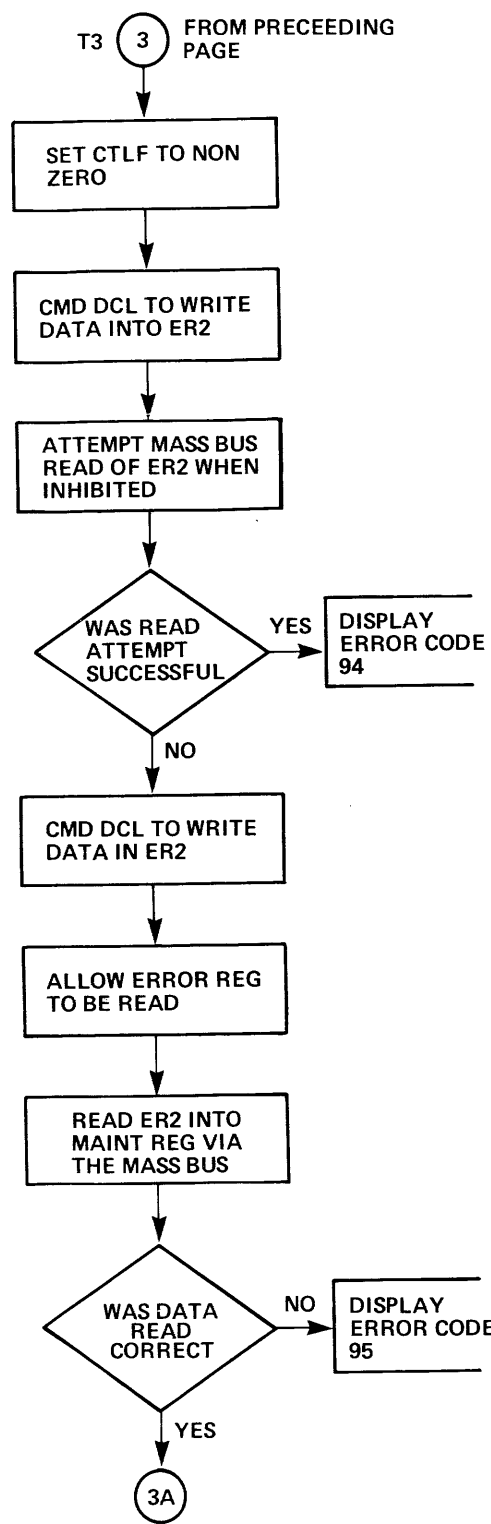

ROUTINE 39, TEST 3 – ER2 + CTLF REGISTER TEST.

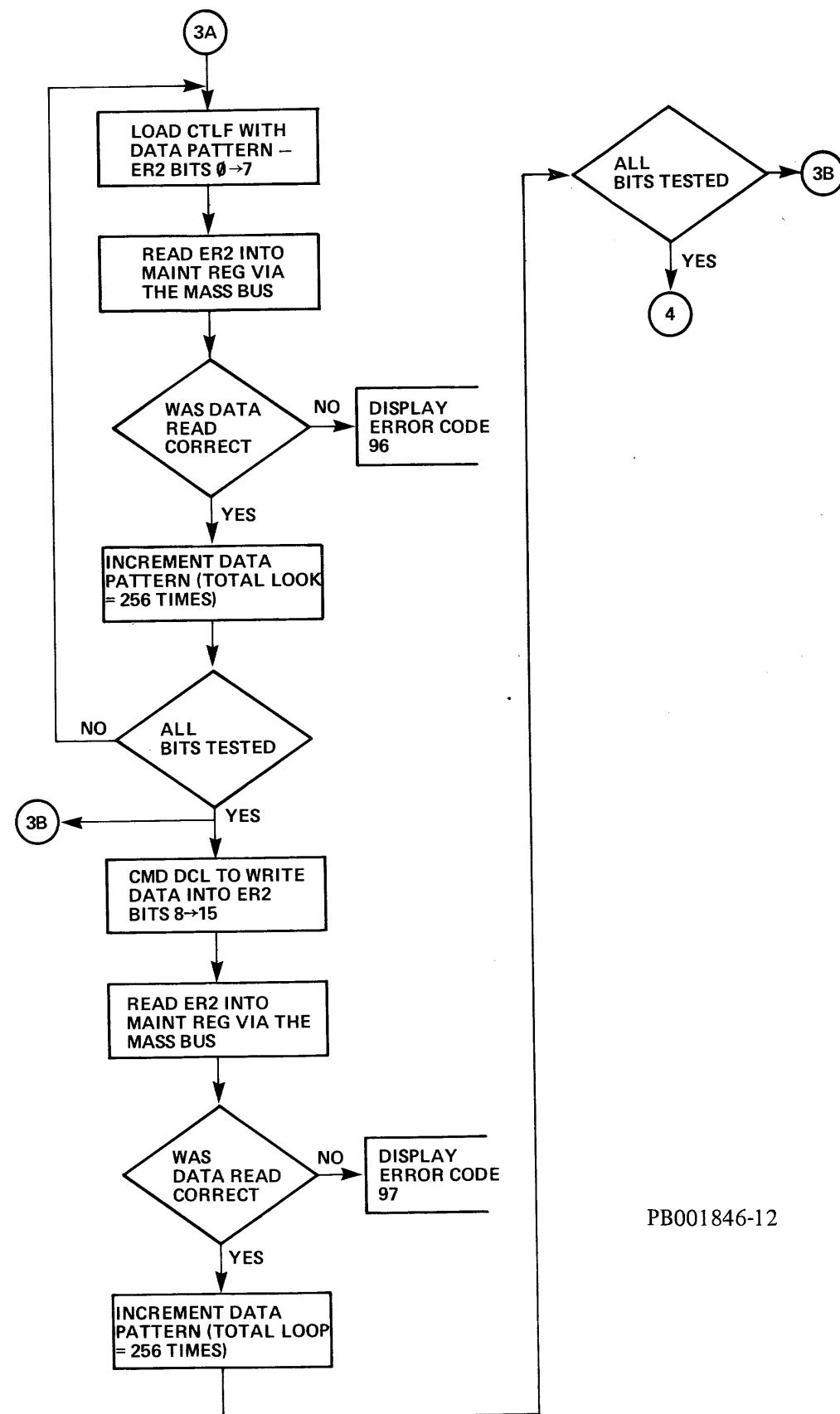

PB001846-12

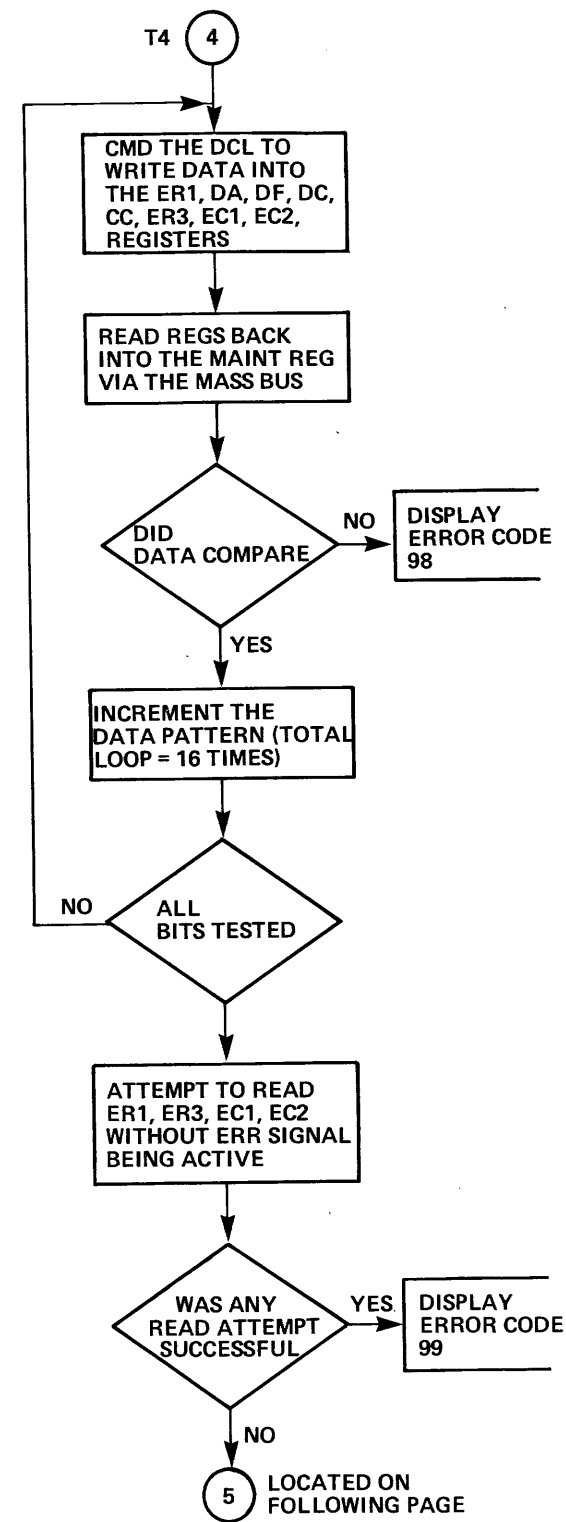

ROUTINE 39, TEST 4 – ER1, DA, DF, DC, CC, ER3, EC1, EC2 REGISTER TEST.

Figure 3-6-42 Full Check on J12 (RTN 39)

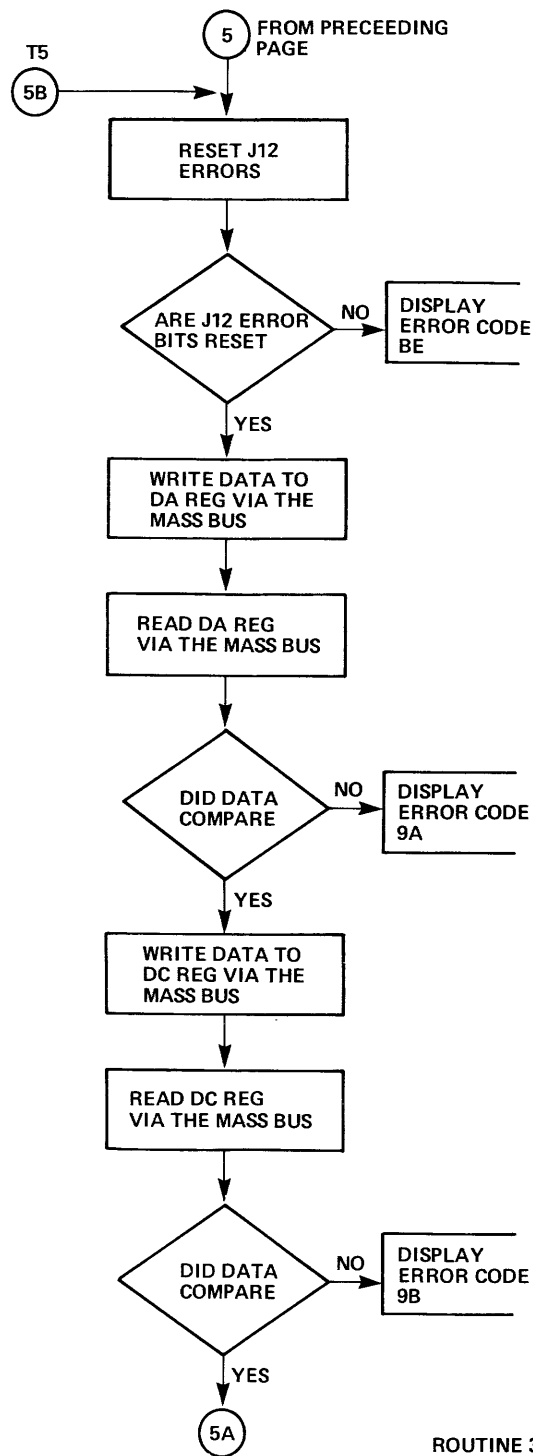

ROUTINE 39, TEST 5 - MASS BUS TEST OF THE 'DA', 'DC', AND 'OF' REGISTERS. ALSO TESTS THE J12 ERROR + VALID BITS.

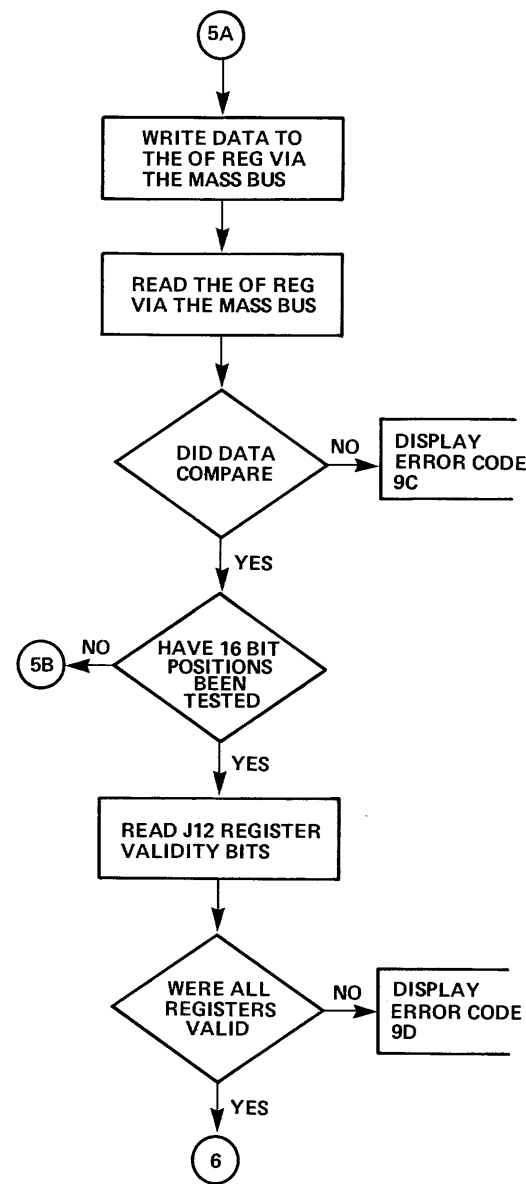

ROUTINE 39, TEST 6 - COMMAND REGISTER TEST AND NOP1/NOP2 COMMAND CHECK.

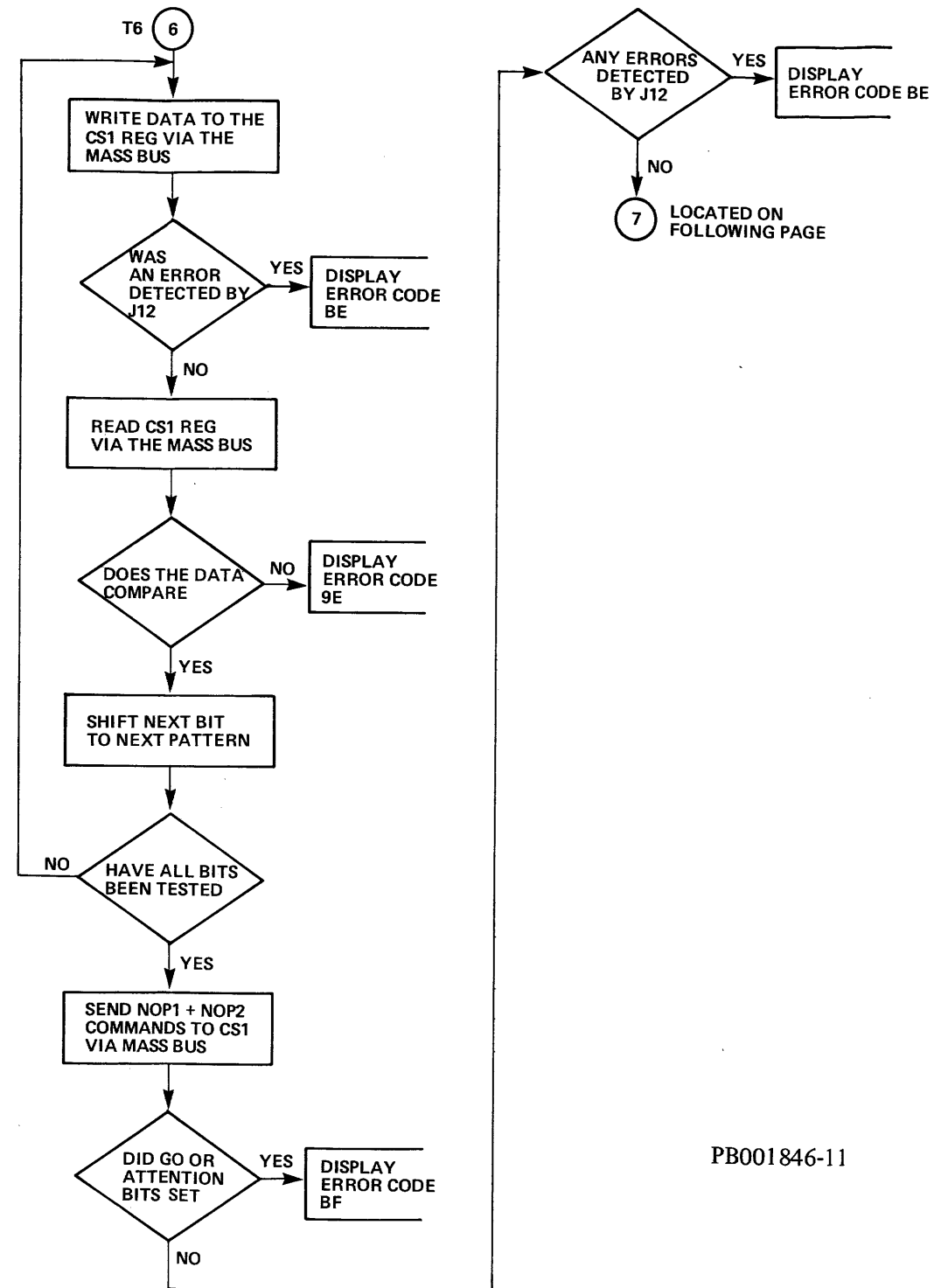

PB001846-11

ROUTINE 39, TEST 7 – THIS TEST ISSUES THE PRESET  
 COMMAND + CHECKS THE INVALID + VALID BITS  
 OF THE DA, DC, + OF REGISTERS.

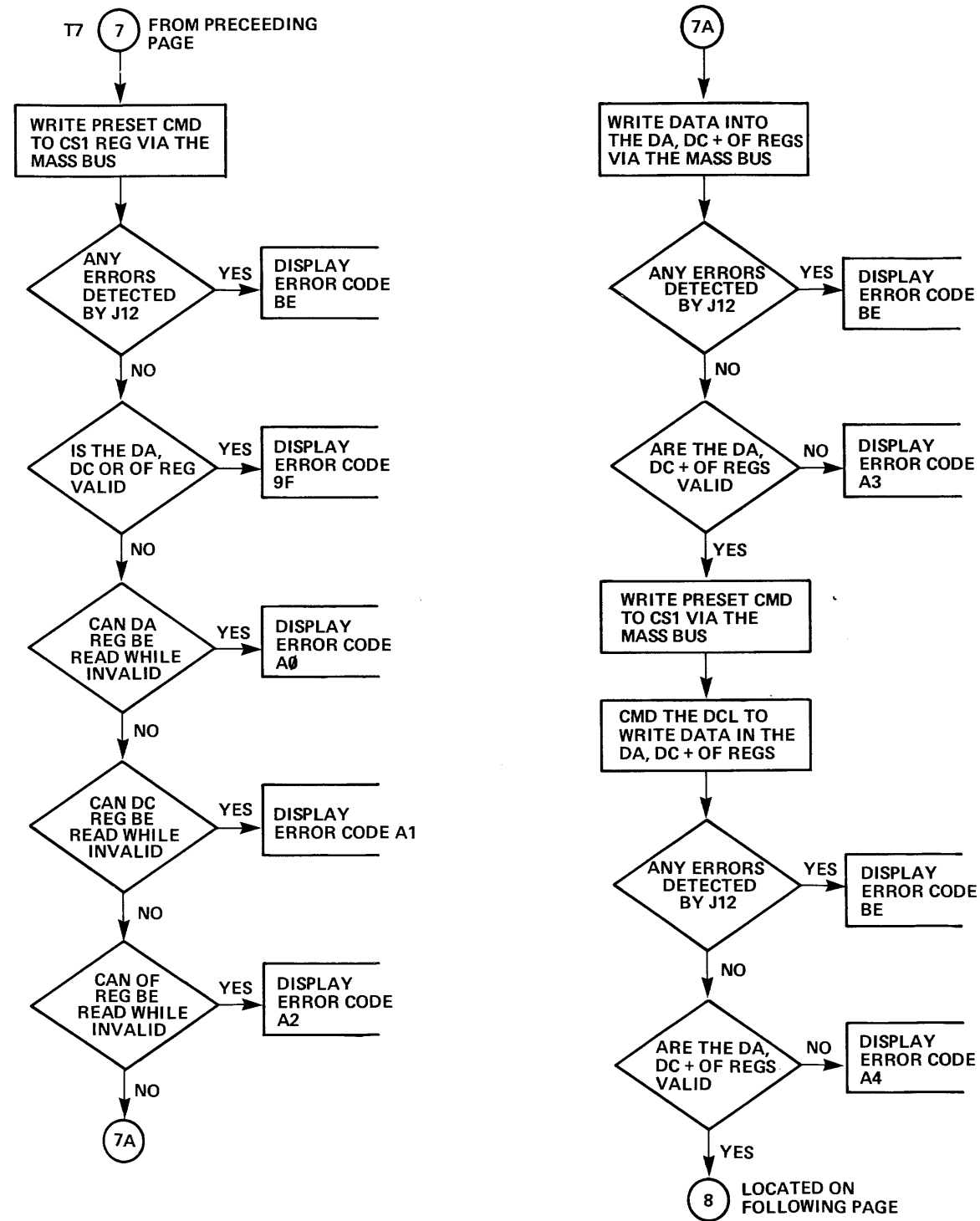

PB001846-4

Figure 3-6-42 Full Check on J12 (RTN 39)  
 Sheet 4 of 7

ROUTINE 39, TEST 8 – INVALID COMMAND TEST  
WITH GOOD + BAD PARITY TO TEST CONTROL  
OF GO + RMR BITS.

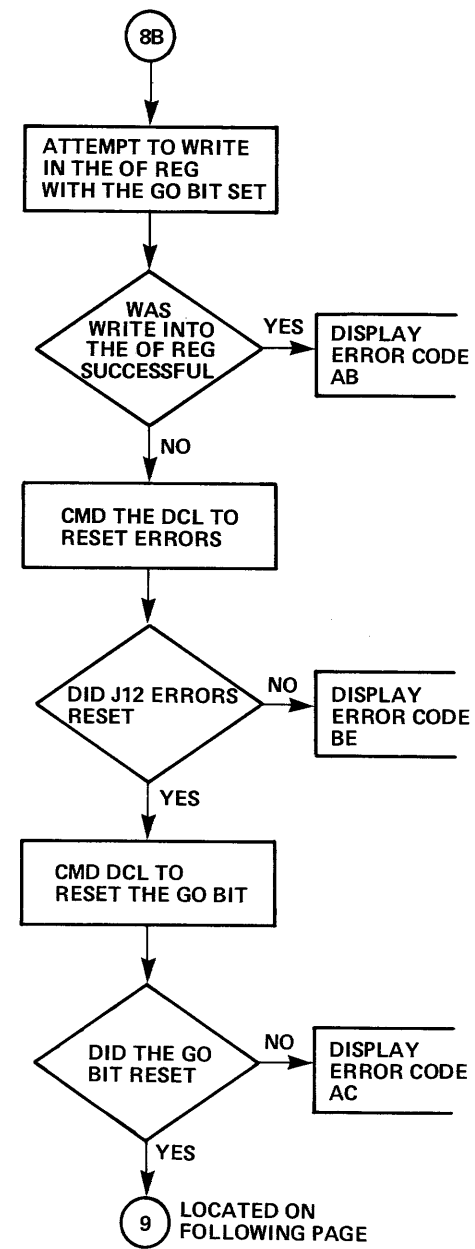
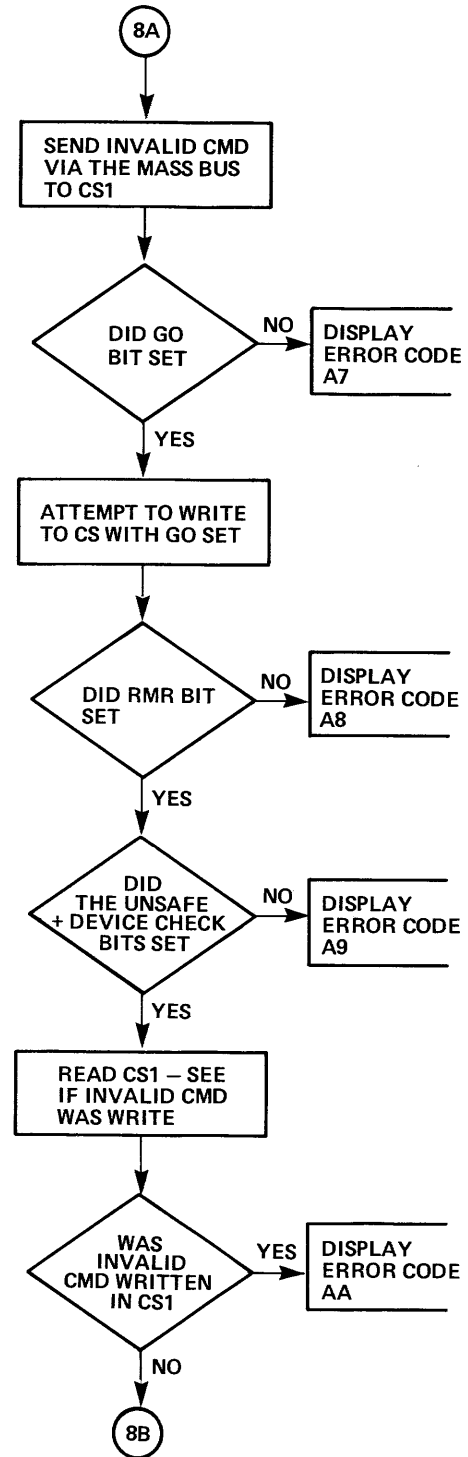
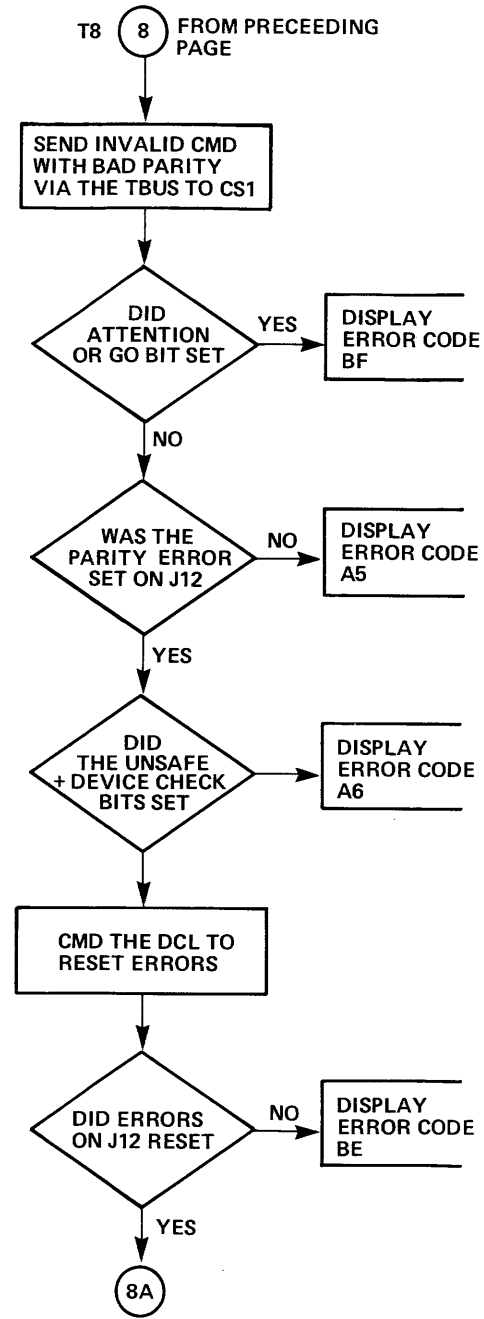

PB001846-10

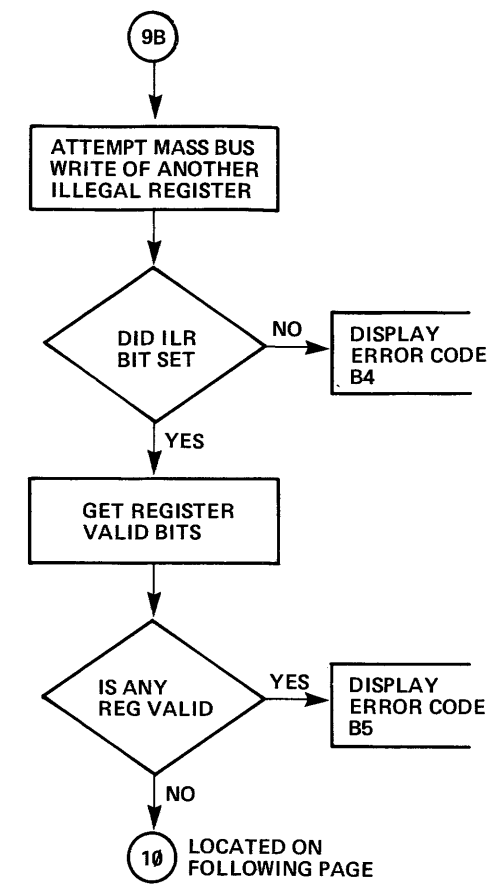
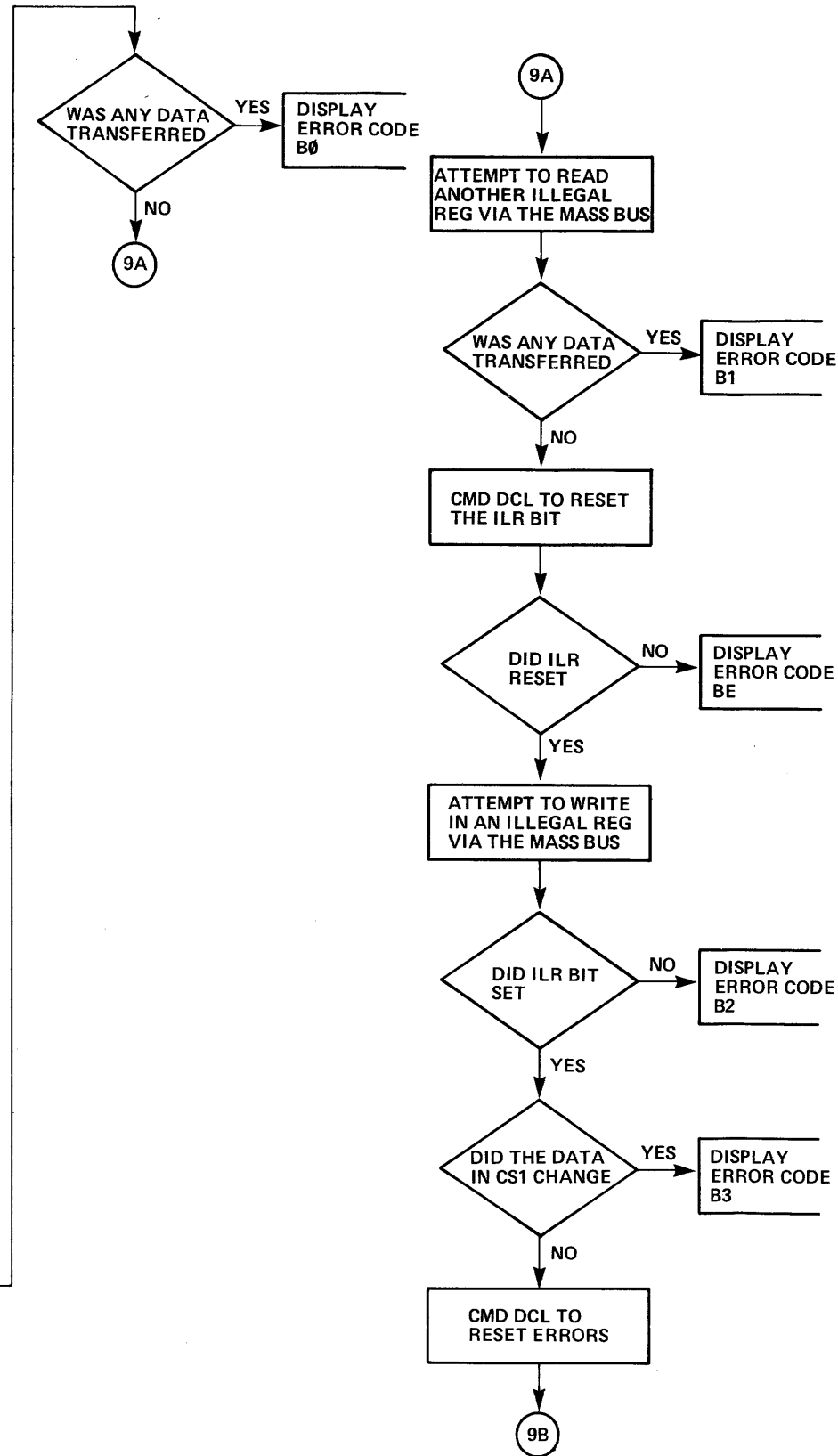
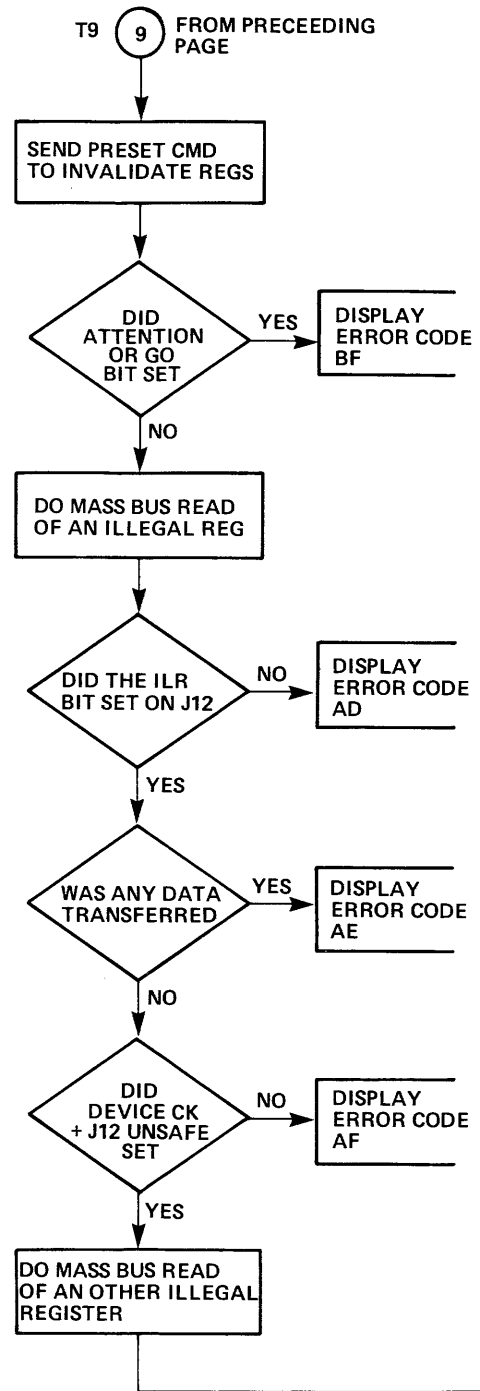

ROUTINE 39, TEST 9 – ILLEGAL REGISTER TEST

PB001846-1

Figure 3-6-42 Full Check on J12 (RTN 39)  
Sheet 6 of 7

ROUTINE 39, TEST 10 – ATTENTION AND INHIBIT WRITE TEST.

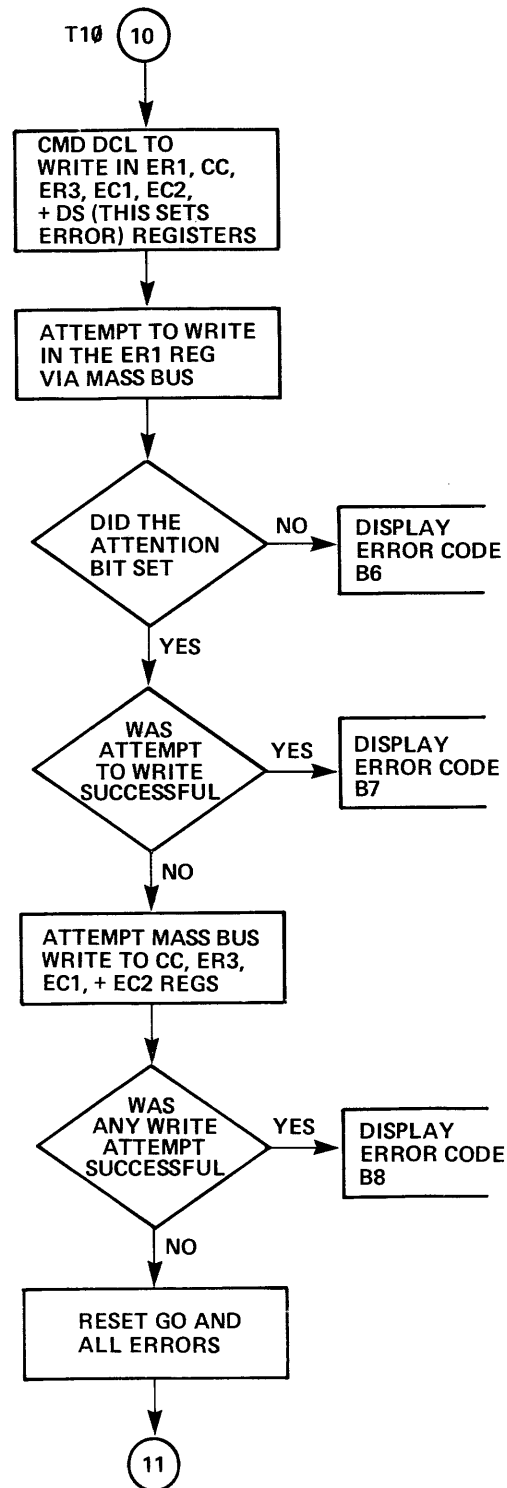

ROUTINE 39, TEST 11 – DIAGNOSTIC COMMAND INTERRUPT + DRIVE CLEAR TEST.

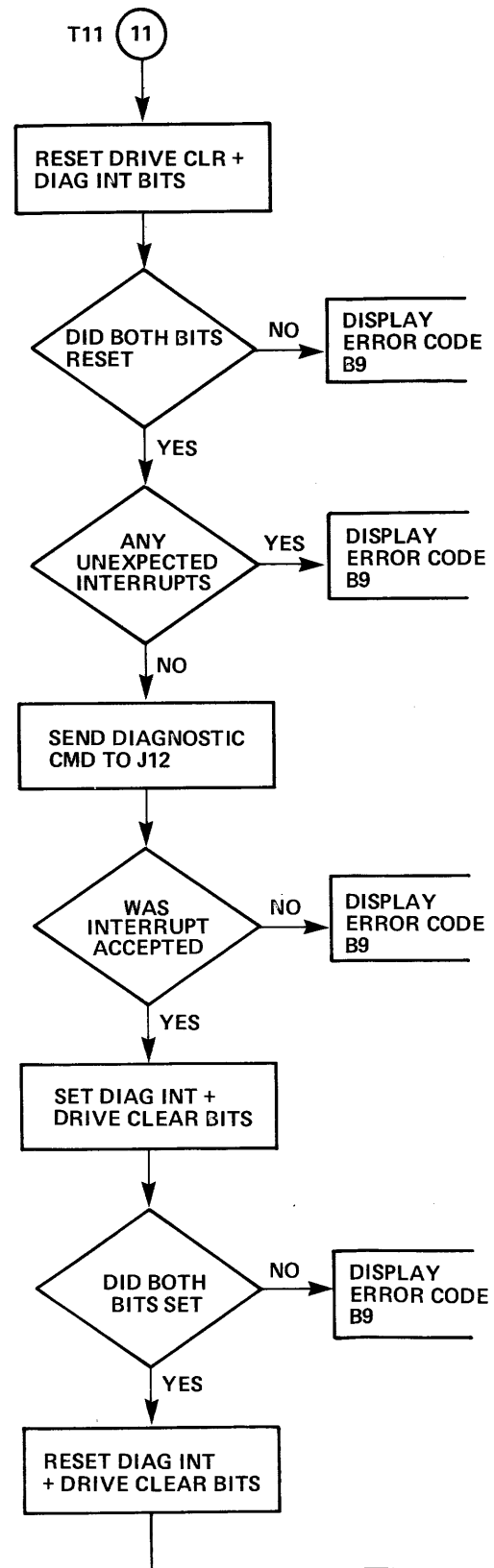

ROUTINE 39, TEST 12 – DMD BIT TEST.

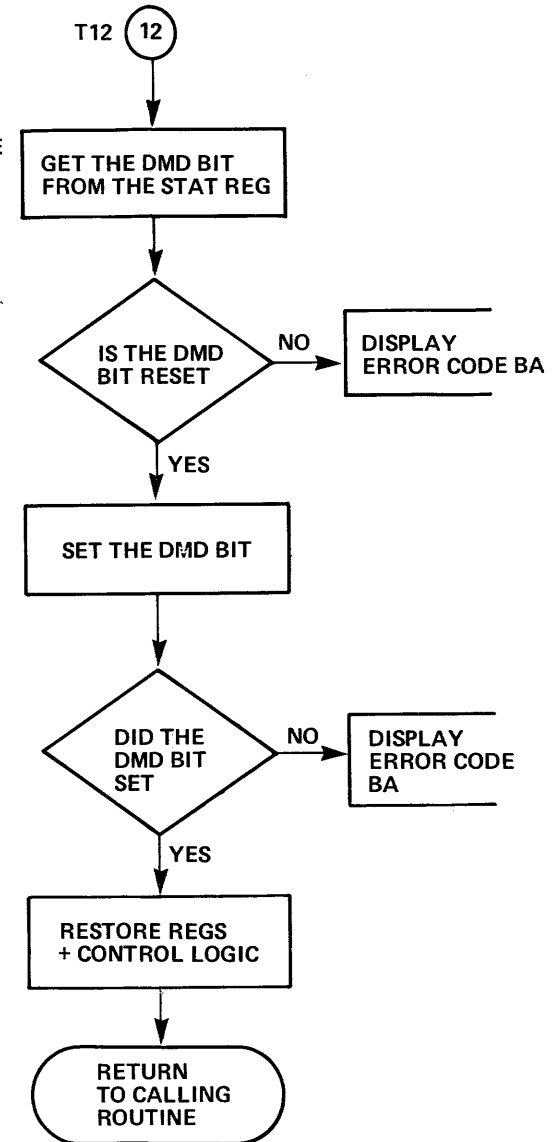

PB001846-14

Figure 3-6-42 Full Check on J12 (RTN 39)  
Sheet 7 of 7



SERDES WRAP CHECK ROUTINE (ROUTINE CODE = 3A)

THIS ROUTINE RUNS A WRAP CHECK ON THE READ/WRITE REGISTER OF THE SERDES PCA (J14).

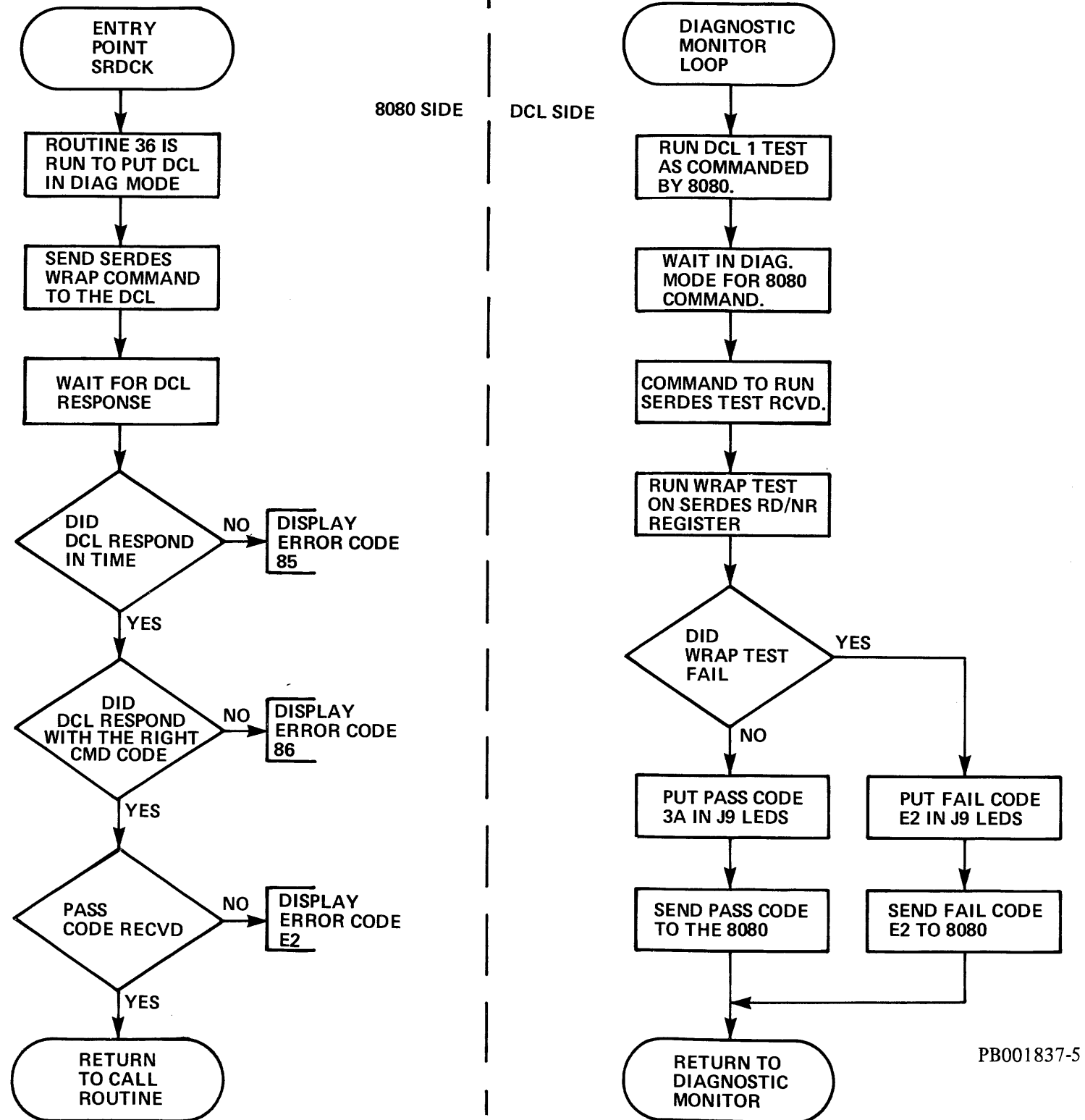

PB001837-5

Figure 3-6-43 SERDES Wrap (RTN 3A)

READ/WRITE SAFETY CHECK ROUTINE (ROUTINE CODE = 3B)

THIS ROUTINE RUNS A WRAP CHECK ON THE R/W DATA CONTROL & HEADER ADDRESS REGISTERS ON THE J16 PCA.

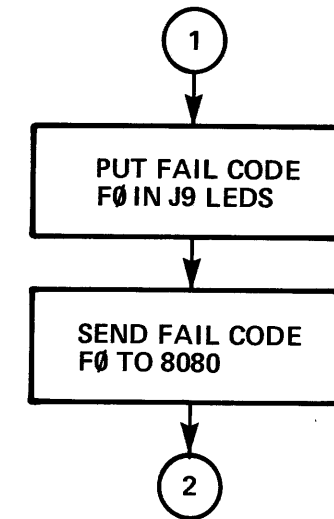
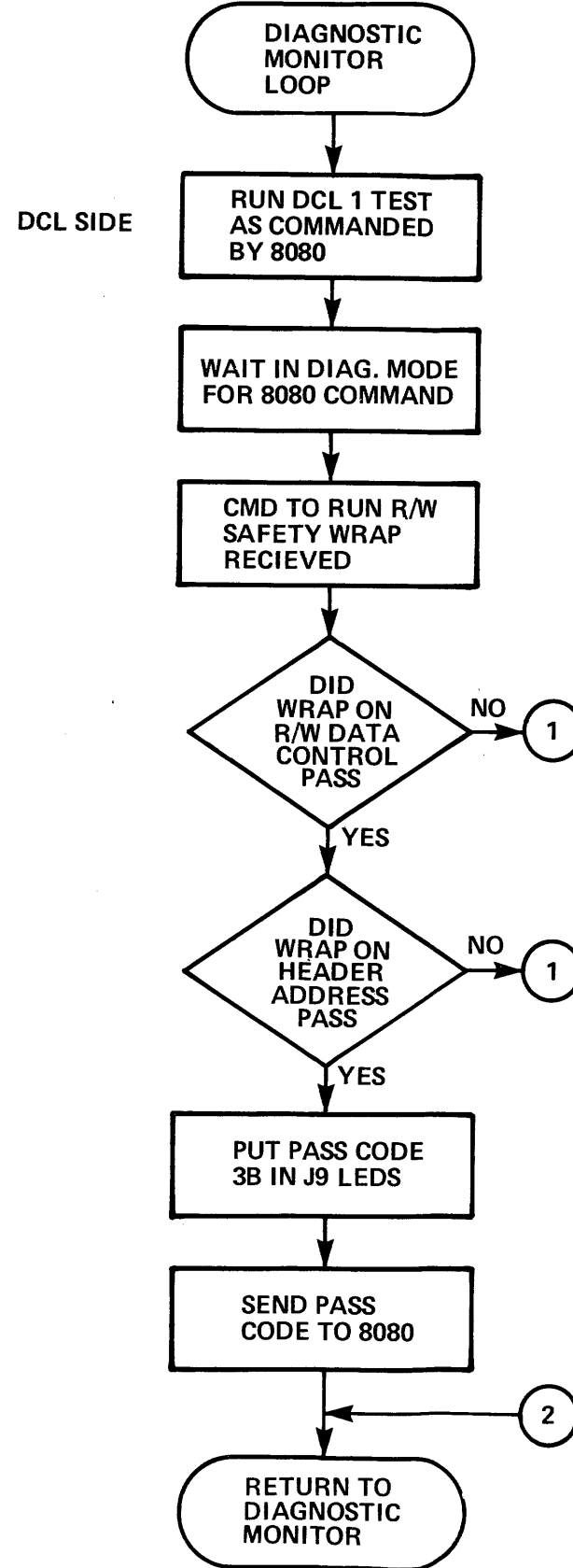
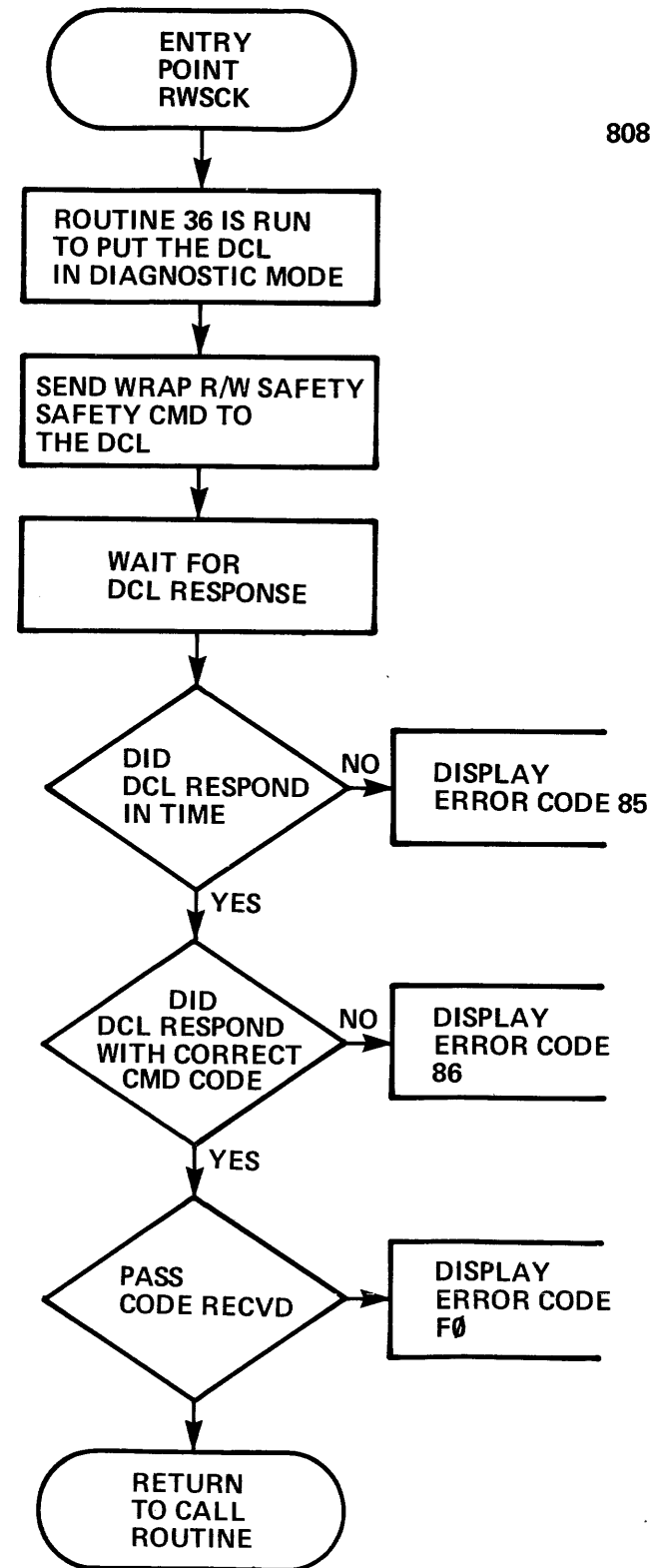

PB001837-4

Figure 3-6-44 R/W Basic (RTN 3B)

DCL UTILITY FOR CONTROL SIGNAL (ROUTINE CODE = 3C)

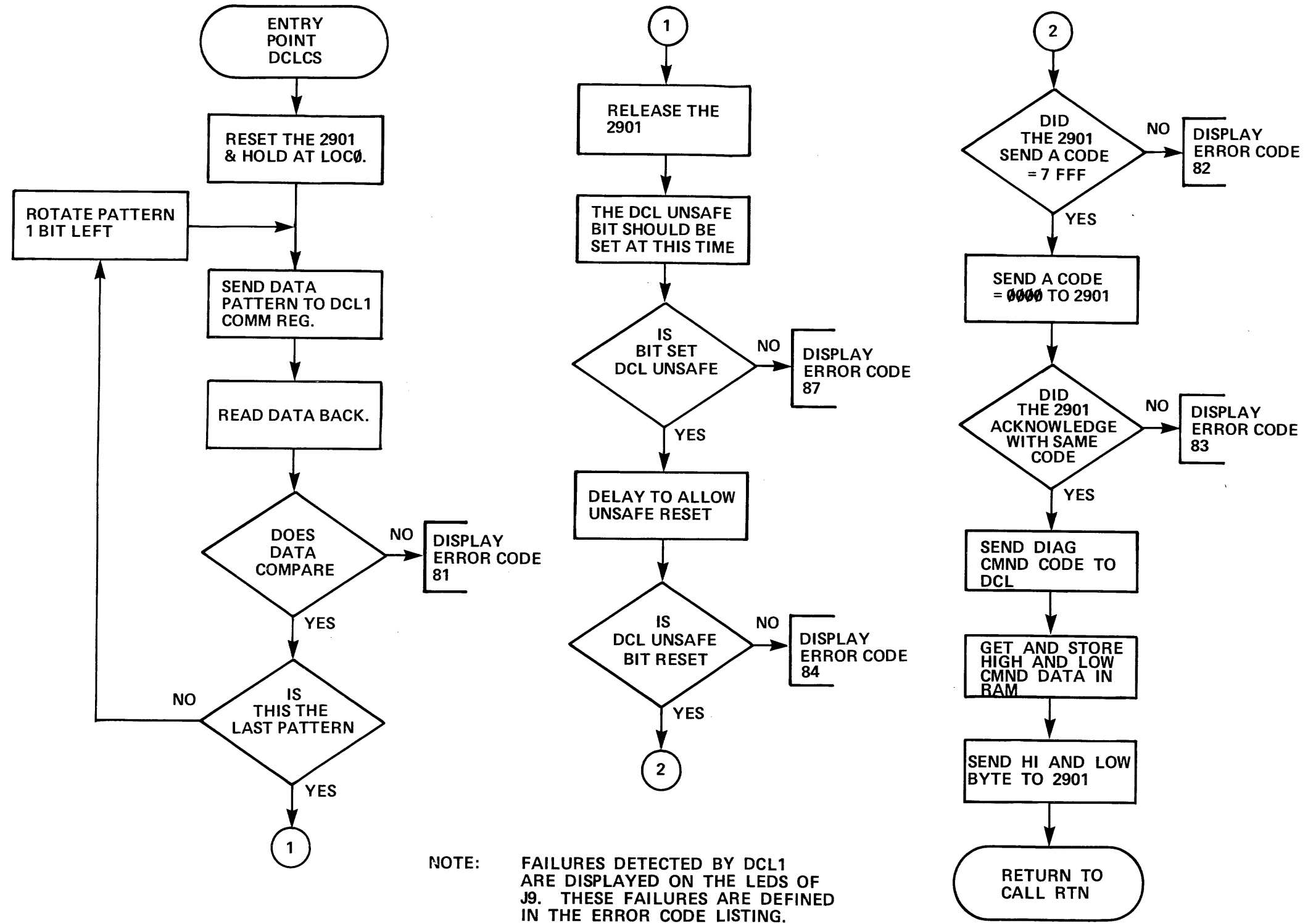

PB001847-4

Figure 3-6-45 DCL Utility for Control Signal (RTN 3C)

8080 UTILITY FOR CONTROL SIGNAL (ROUTINE CODE = 3D)

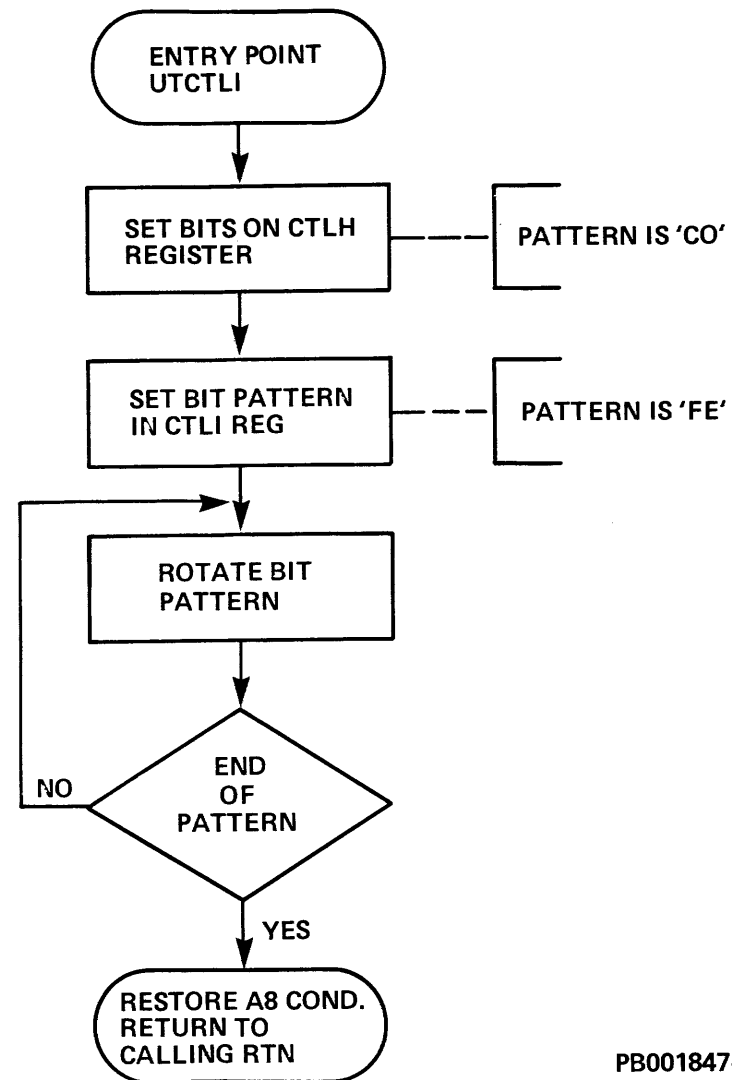

PB001847-5

PACK SPIN UP UTILITY (ROUTINE CODE = 3E)

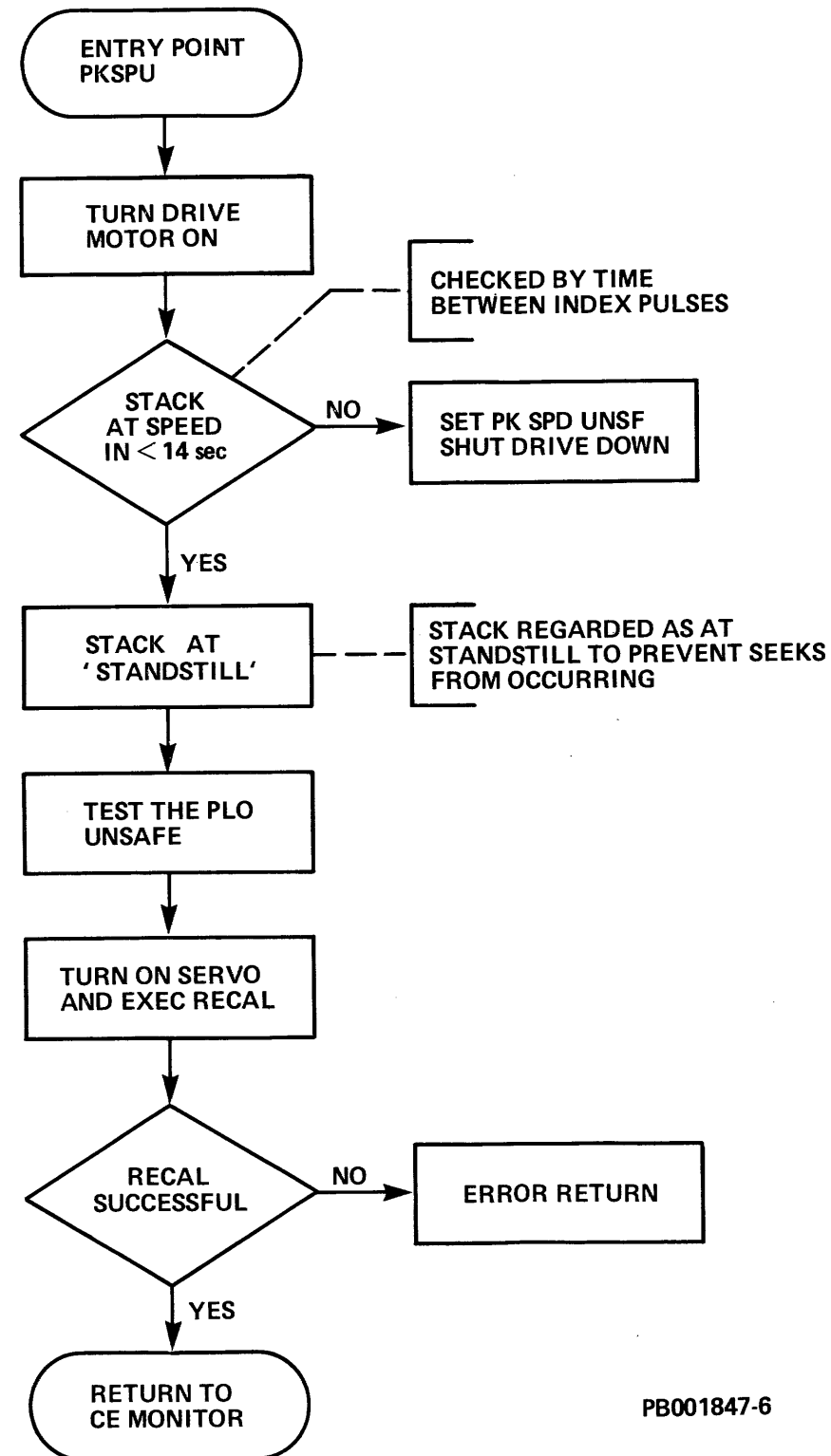

PB001847-6

PACK SPIN DOWN UTILITY (ROUTINE CODE = 3F)

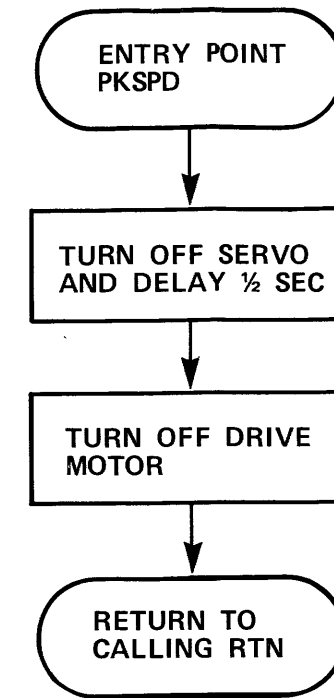

PB001847-3

Figure 3-6-46 8080 Utility for Control Signal (RTN 3D)

Figure 3-6-47 Pack Spin Up Utility (RTN 3E)

Figure 3-6-48 Pack Spin Down Utility (RTN 3F)

READ CROM DCL1/2 ROUTINE (ROUTINE CODE = 40)  
UTILITY ROUTINE TO READ ANY LOCATION IN CROM MEMORY.

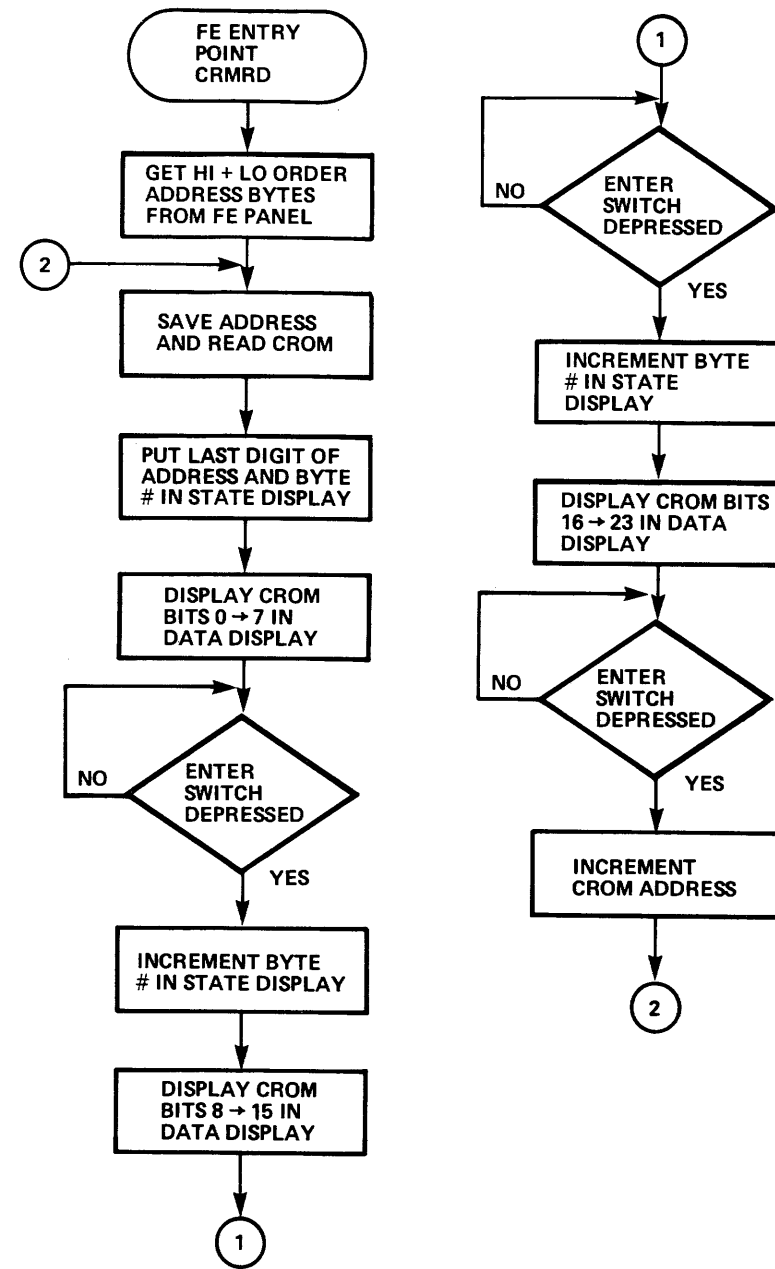

PB001872-1

ZERO THE ERROR LOG (ROUTINE CODE = 45)  
UTILITY ROUTINE TO CLEAR THE ERROR LOG IN RAM.

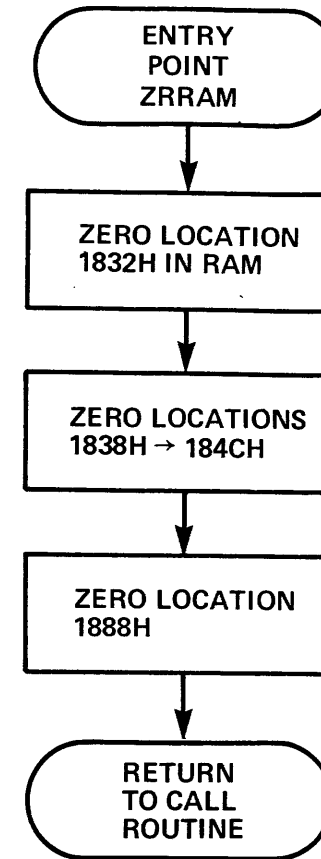

PB001872-3

Figure 3-6-49 CROM Read Utility (RTN 40)

Figure 3-6-50 Zero RAM Read (RTN 45)

TACH CALIBRATION UTILITY (ROUTINE CODE = 46)  
 UTILITY ROUTINE TO ALLOW THE FE TO RUN THE  
 TACH CALIBRATION FROM THE FE PANEL.

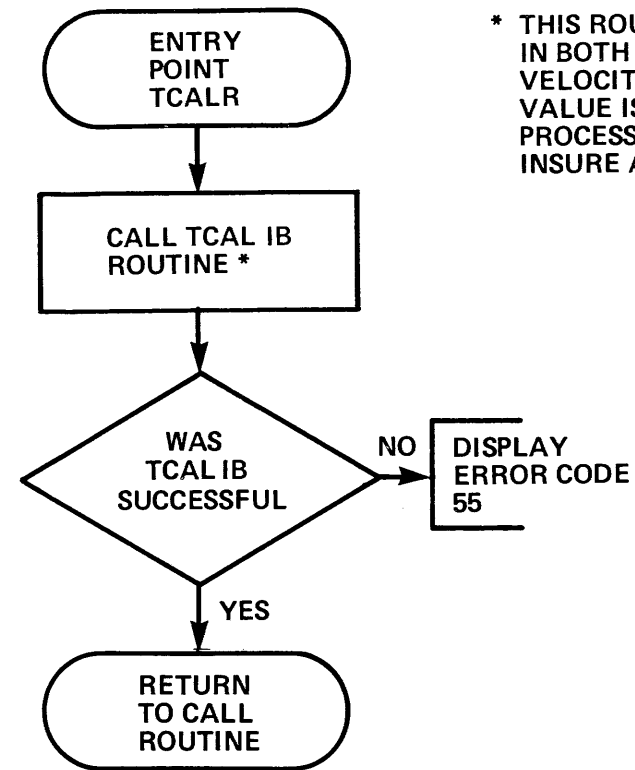

\* THIS ROUTINE CALIBRATES THE TACHOMETER IN BOTH HIGH AND LOW SLEW RATES. IF THE ACTUAL VELOCITY IS NOT WITHIN BOUNDS THE AGE REF. VALUE IS INCREASED OR DECREASED AND THE PROCESS IS REPEATED. TIMER 3 IS SET UP TO INSURE AGAINST PROGRAM HANG UP.

PB001872-4

TEST ALL ROUTINE (ROUTINE CODE = 47)  
 UTILITY ROUTINE WHICH RUNS THE MAJORITY  
 OF ROUTINES CALLED DURING DRIVE INITIALIZATION.

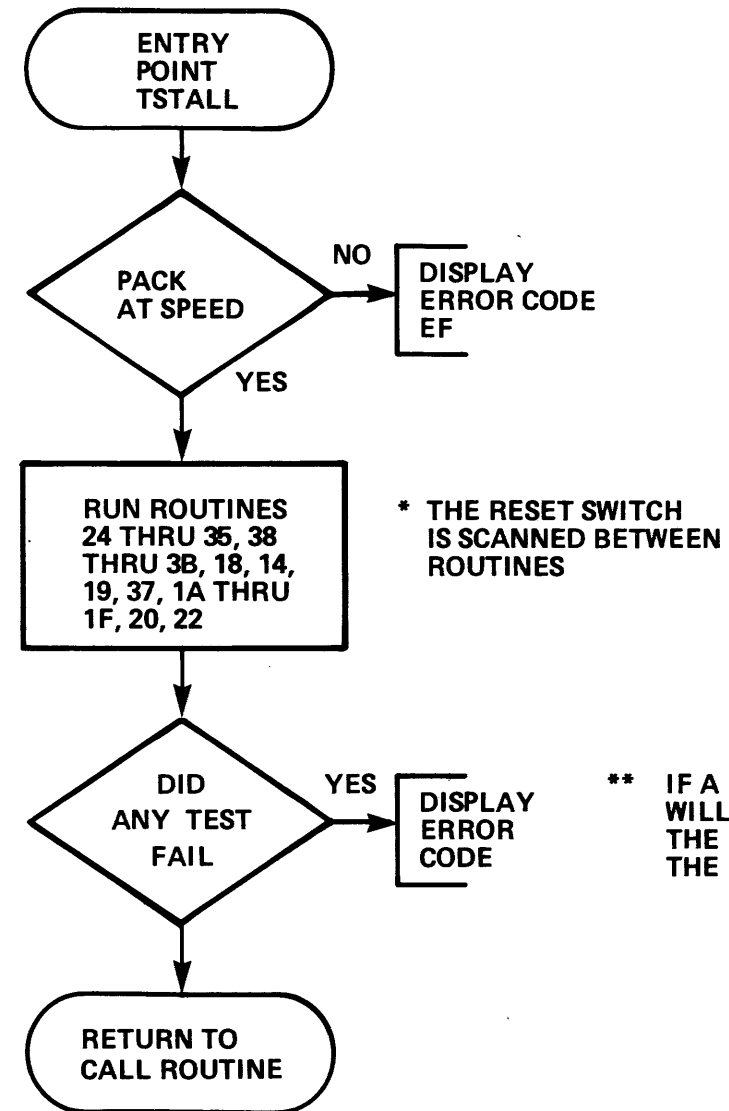

\* THE RESET SWITCH IS SCANNED BETWEEN ROUTINES

\*\* IF A ROUTINE FAILS THE TEST WILL STOP AT THAT POINT WITH THE ERROR CODE DISPLAYED IN THE FE PANEL.

PB001872-2

Figure 3-6-51 Tachometer Calibration (RTN 46)

Figure 3-6-52 Test all Initialization Routines (RTN 47)

## CHAPTER 4

### REMOVAL AND REPLACEMENT

#### WARNING

HAZARDOUS VOLTAGES ARE PRESENT INSIDE THIS EQUIPMENT. INSTALLATION AND SERVICING SHOULD BE PERFORMED BY A QUALIFIED AND TRAINED SERVICE REPRESENTATIVE. BODILY INJURY OR EQUIPMENT DAMAGE MAY RESULT FROM IMPROPER SERVICING. REFER TO THE SERVICE MANUAL FOR PROPER INSTRUCTIONS.

#### 4.0 INTRODUCTION

The removal and replacement procedures described in Subsection 4.2 of this manual, pertain to items most likely to be removed and replaced, as well as those items which are difficult or critical to remove and replace. To provide the Field Engineer (FE) with assembly, subassembly and component accessibility, procedures for the removal and replacement of service covers are also included.

To aid the FE in part identification, refer to the Illustrated Parts Breakdown Manual (ER-ORP07-IPB). The Illustrated Parts Breakdown Manual provides isometric illustrations (usually including attaching hardware), which are helpful when performing the Removal and Replacement procedures.

To aid the FE in part location, see Subsection 4.1 of this chapter, Assembly and Subassembly Locator.

Due to the design of the RP07 there are no drive adjustments.

#### NOTE

It is recommended that FEs read and familiarize themselves with the removal and replacement procedures before attempting to perform them.

#### 4.1 ASSEMBLY AND SUBASSEMBLY LOCATOR

Figure 4-1-A identifies all major assemblies and subassemblies within the RP07 Disk Drive. Reference designators are given where applicable.

NOTES:

- (1) SUBSECTIONS 4.2.1.1 4.2.1.2
- (2) SUBSECTIONS 4.2.8
- (3) SUBSECTIONS 4.2.16
- (4) SUBSECTIONS 4.2.11
- (5) SUBSECTIONS 4.2.5
- (6) SUBSECTIONS 4.2.6
- (7) SUBSECTIONS 4.2.6.2
- (8) SUBSECTIONS 4.2.9
- (9) SUBSECTIONS 4.2.2
- (10) SUBSECTIONS 4.2.14
- (11) SUBSECTIONS 4.2.21
- (12) SUBSECTIONS 4.2.22
- (13) SUBSECTIONS 4.2.20
- (14) SUBSECTIONS 4.2.20.5
- (15) SUBSECTIONS 4.2.20.6
- (16) SUBSECTIONS 4.2.20.2
- (17) SUBSECTIONS 4.2.20.3
- (18) SUBSECTIONS 4.2.20.4
- (19) SUBSECTIONS 4.2.20.1
- (20) SUBSECTIONS 4.2.15
- (21) SUBSECTIONS 4.2.10
- (22) SUBSECTIONS 4.2.19

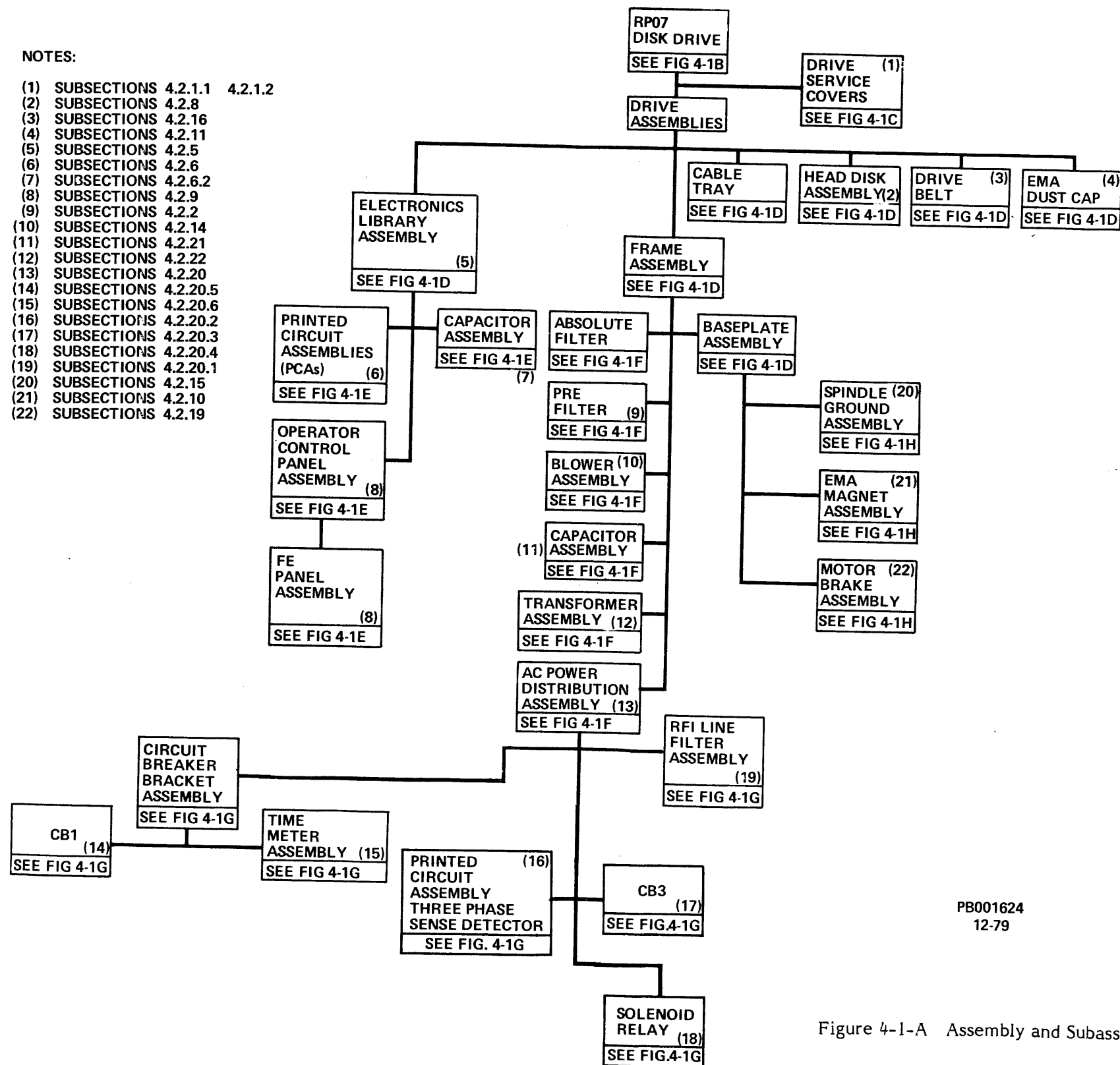

PB001624  
12-79

Figure 4-1-A Assembly and Subassembly Locator



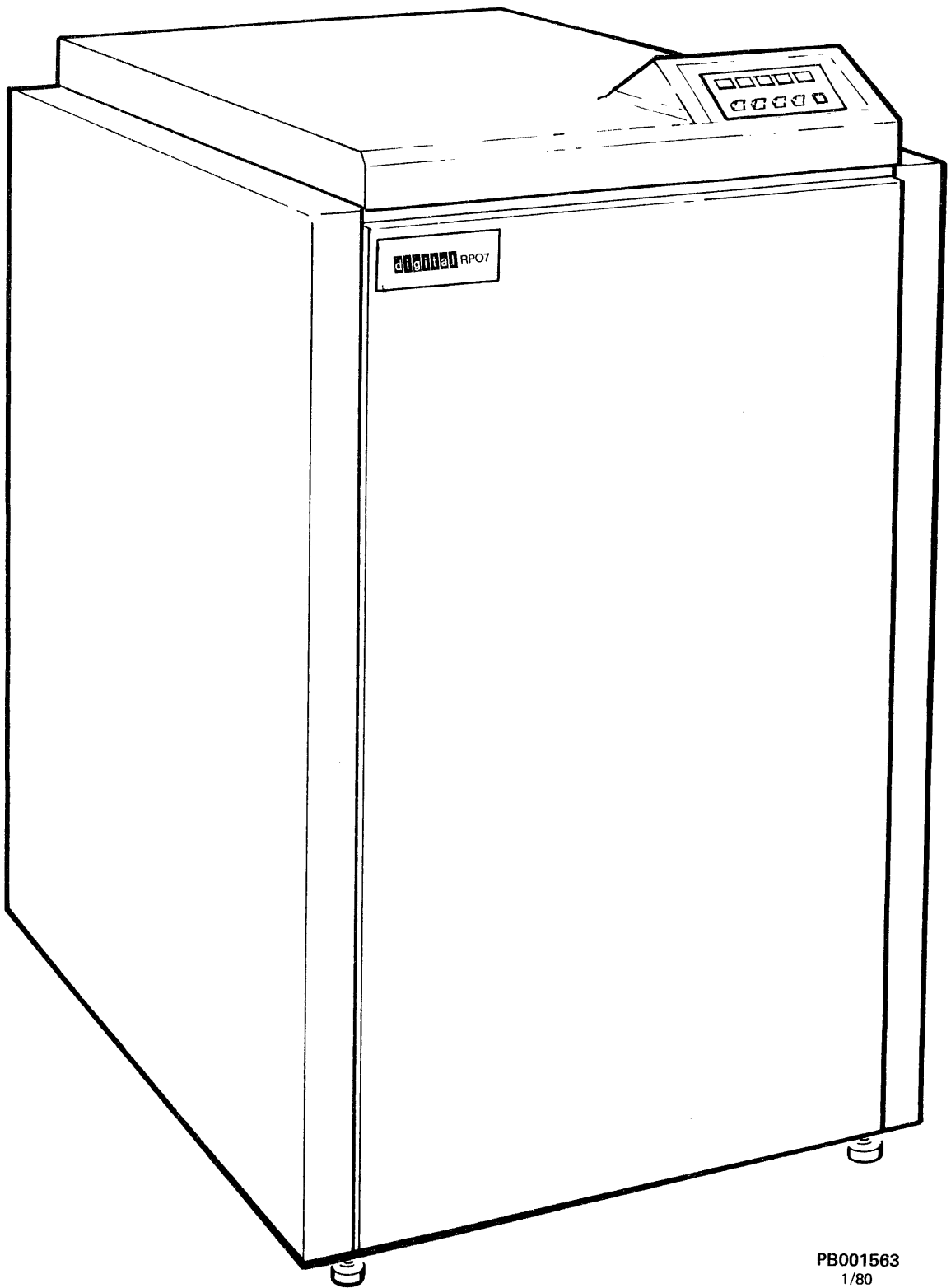

PB001563  
1/80

Figure 4-1-B RP07 Disk Drive

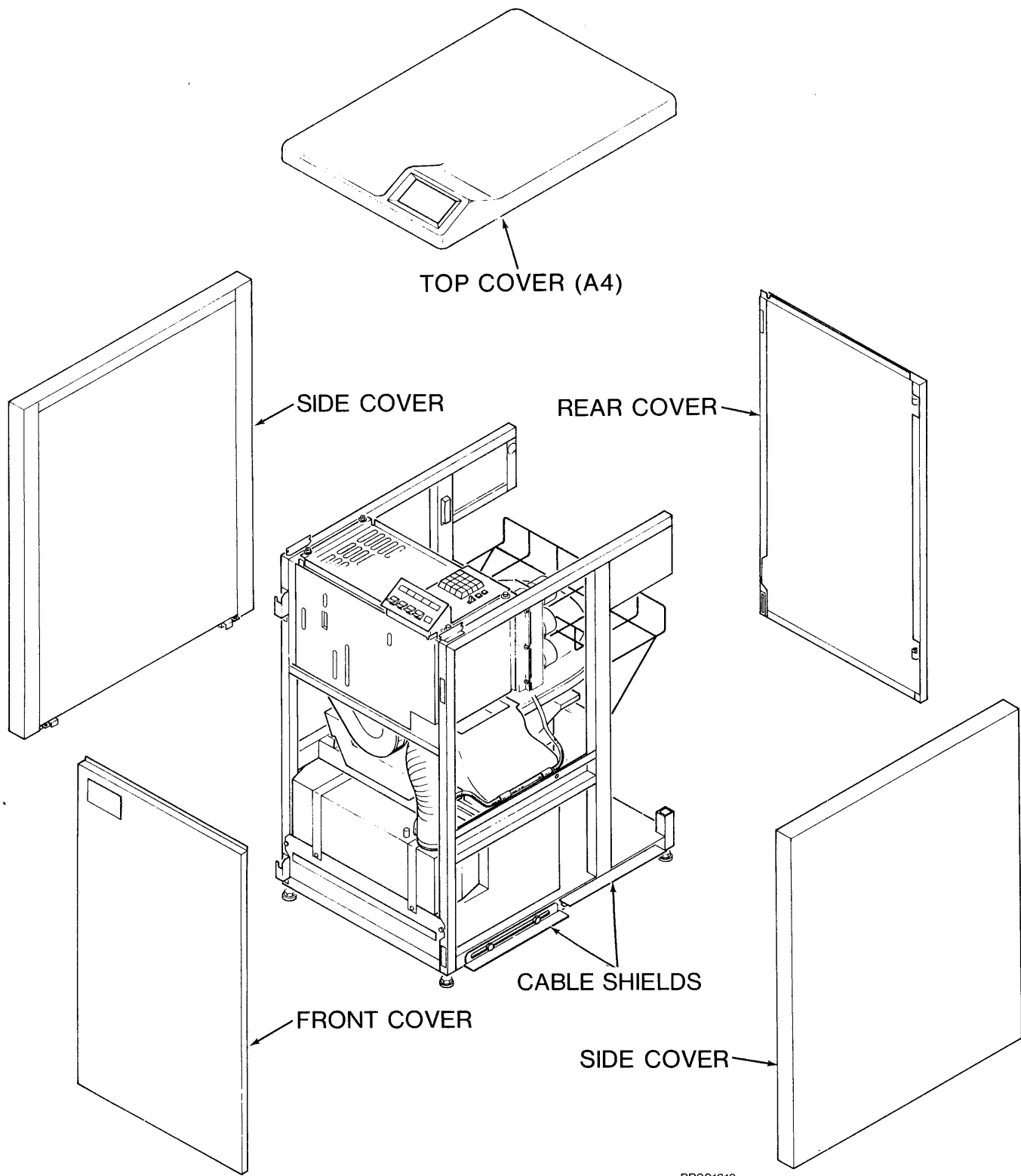

PB001613  
12/82

Figure 4-1-C Drive Service Covers

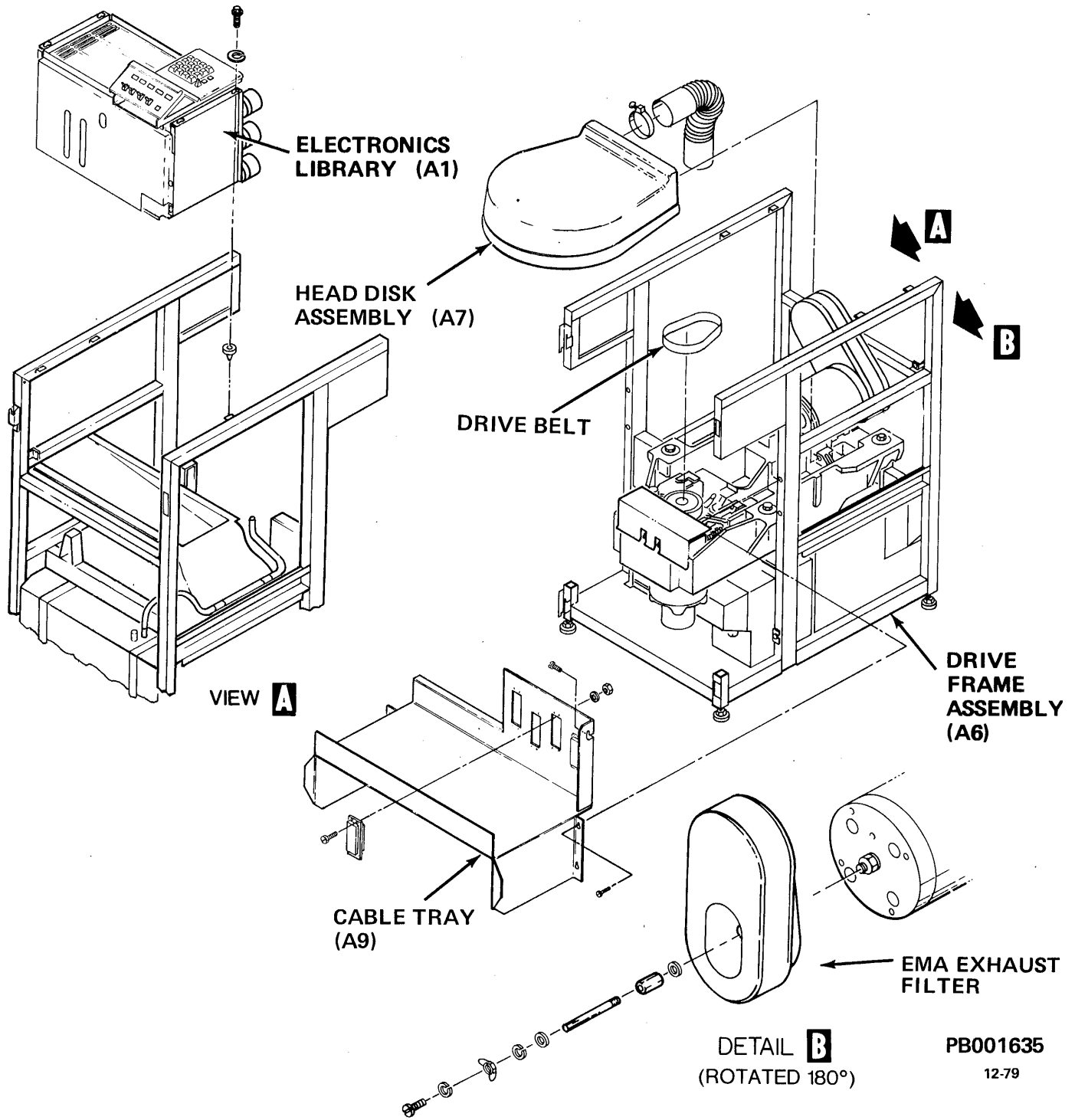

PB001635

12-79

Figure 4-1-D Drive Assemblies

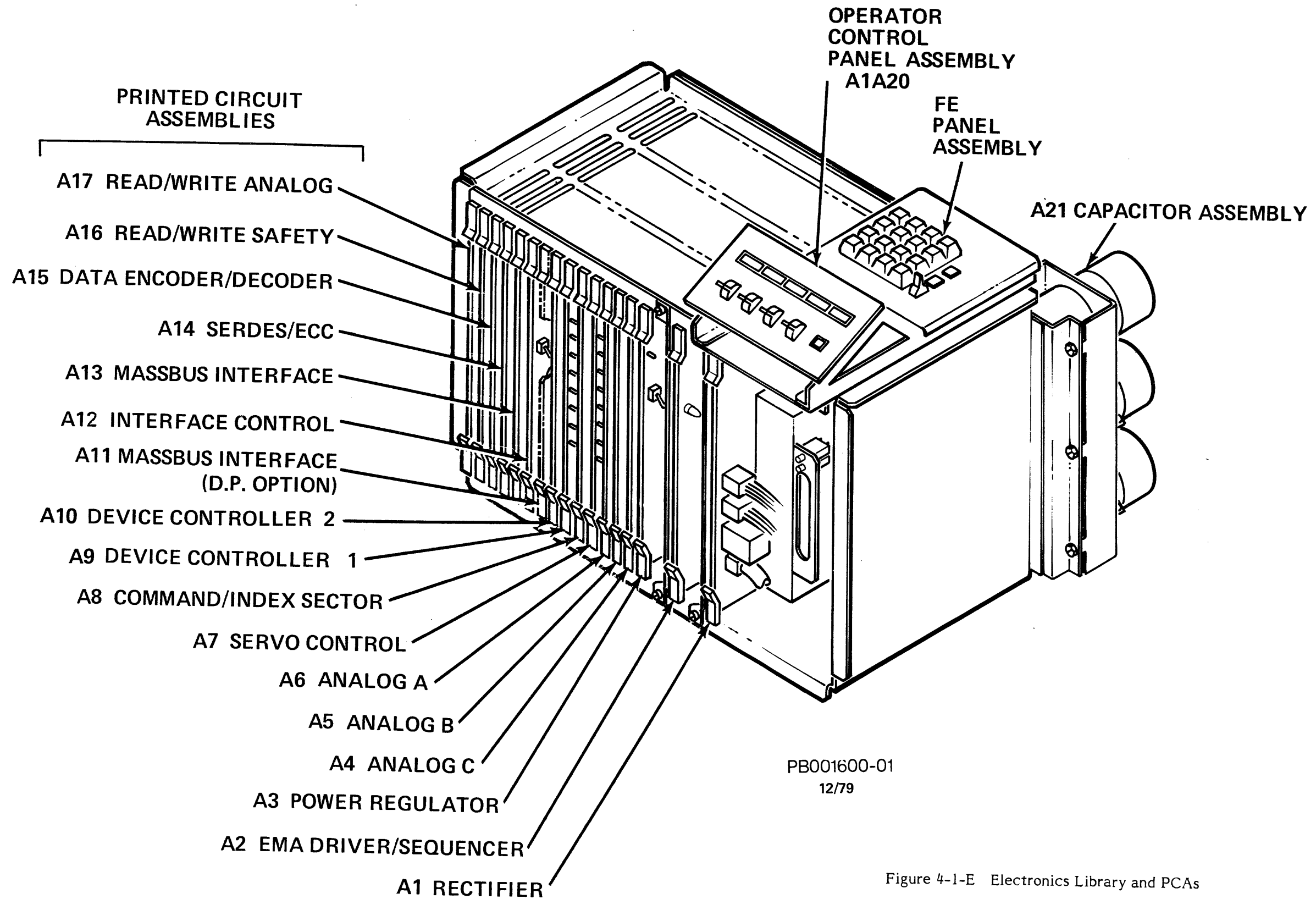

Figure 4-1-E Electronics Library and PCAs

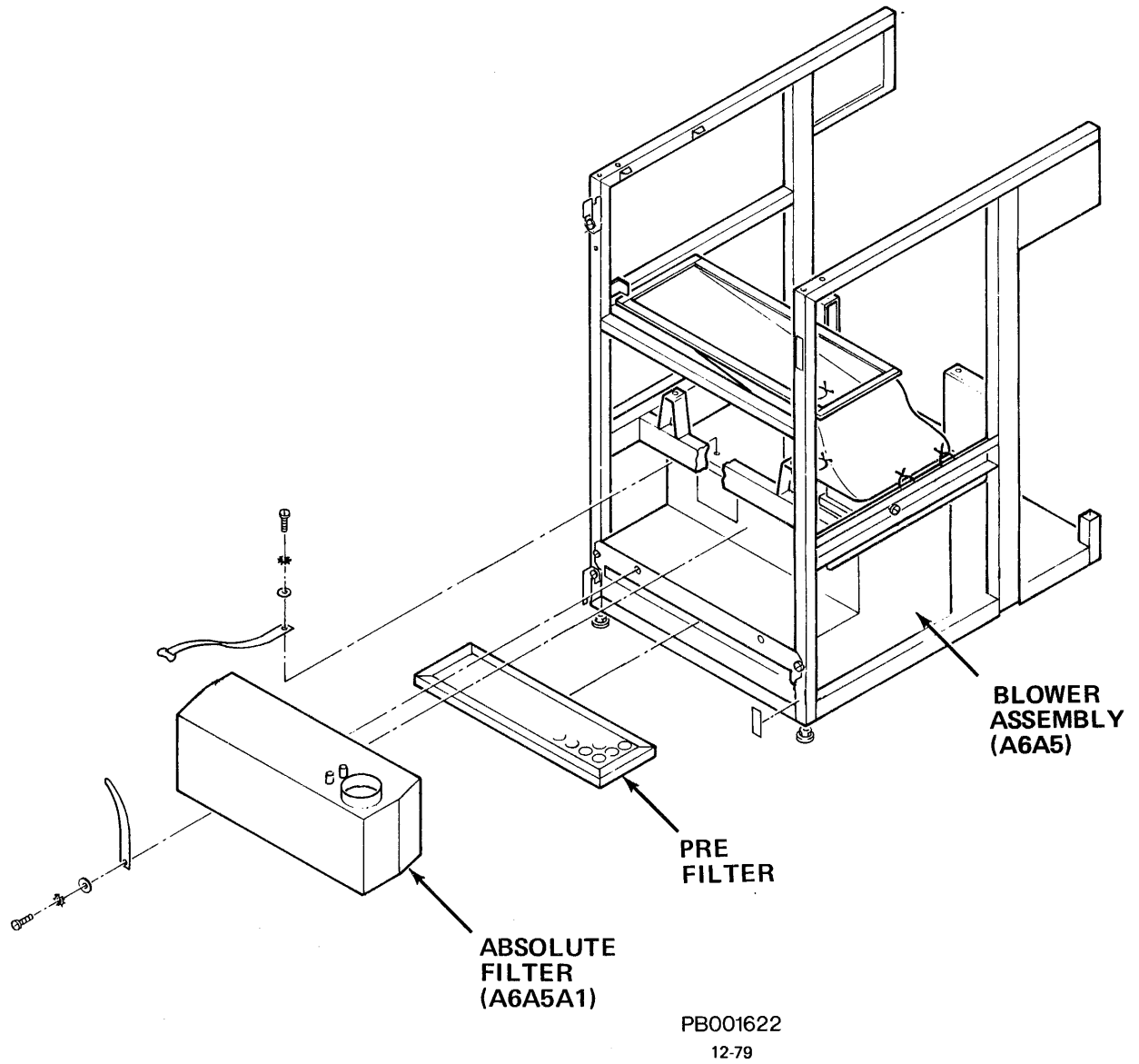
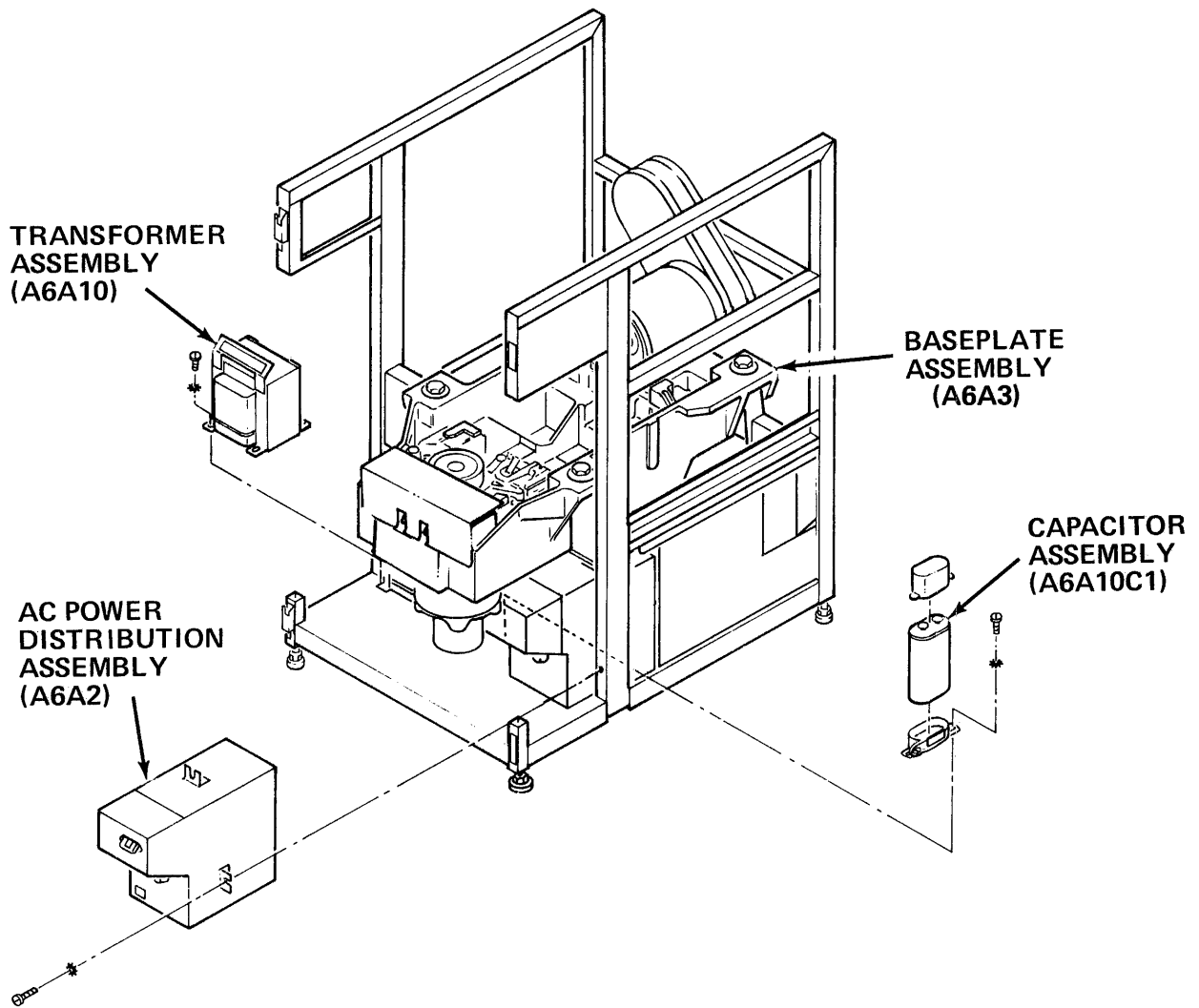

Figure 4-1-F Drive Frame Assemblies (Front View)  
(Sheet 1 of 2)



PB001623

12-79

Figure 4-1-F Drive Frame Assemblies (Rear View)  
(Sheet 2 of 2)

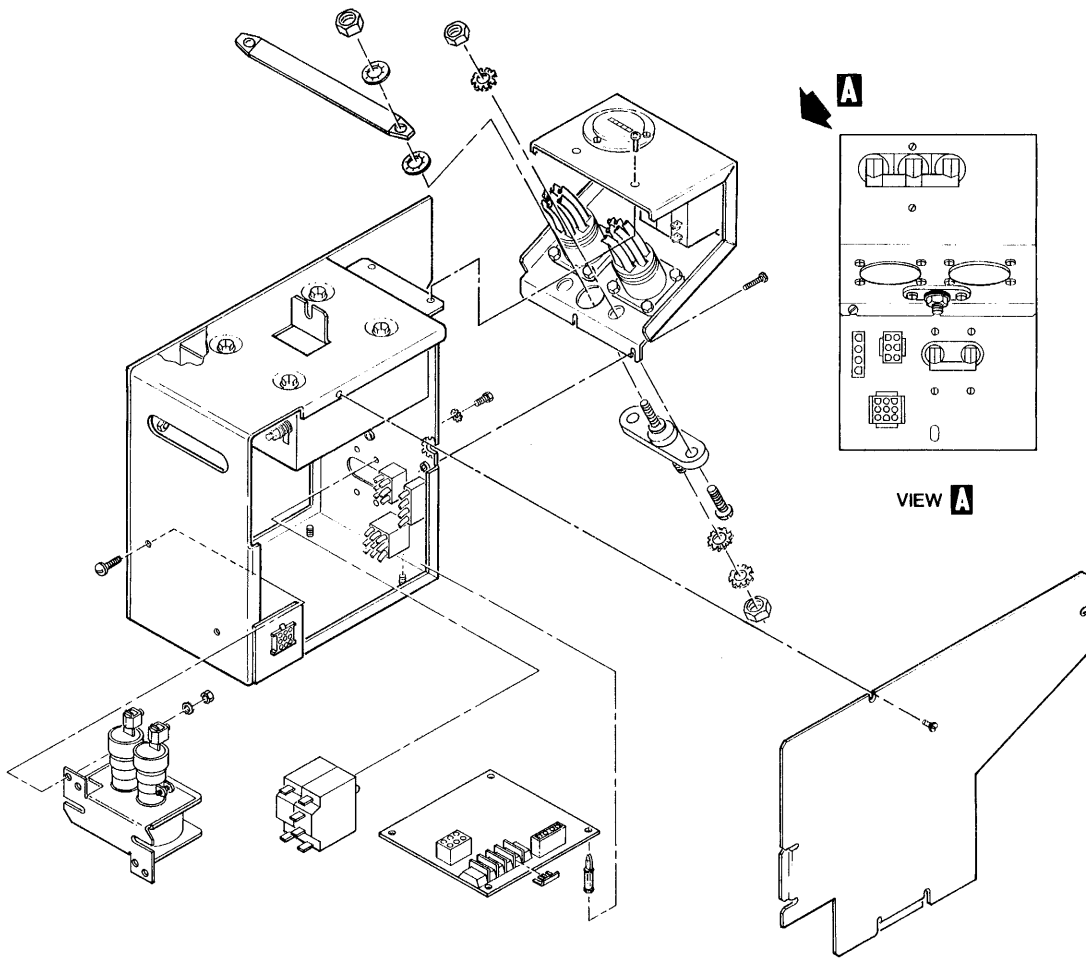

PC035671-1

Figure 4-1-G AC Power Distribution Assembly (Exploded View)

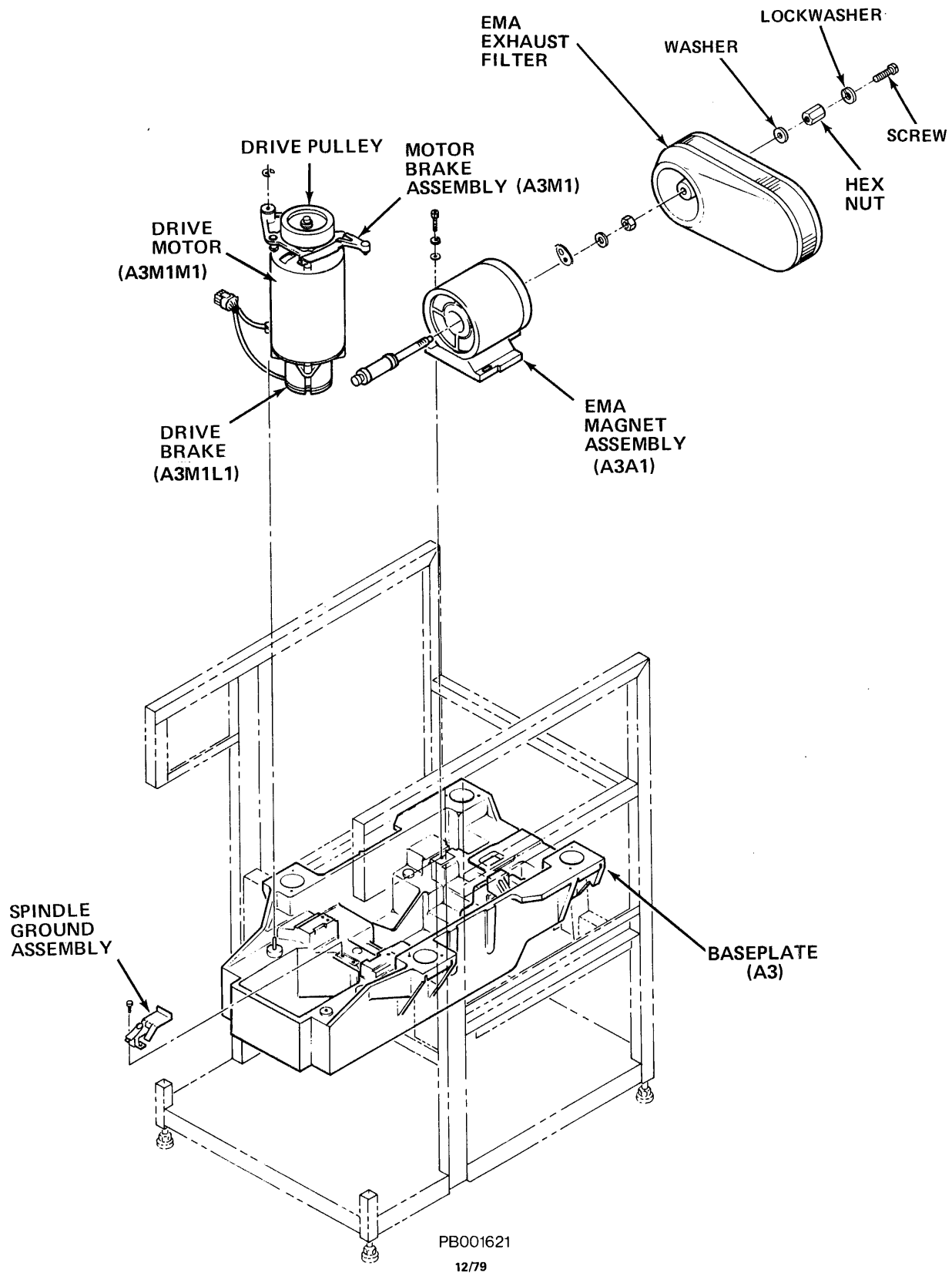

Figure 4-1-H Baseplate Assembly



## 4.2 REMOVAL AND REPLACEMENT PROCEDURES

### 4.2.1 Service Covers

Five easily removable service covers allow quick access to the drive for maintenance. The top cover assembly can be raised and held open with its U-shaped support rod to allow access to the FE Control Panel.

#### 4.2.1.1 Top Cover Assembly (A4)

##### To open the top cover:

1. Insert a screwdriver (or a pencil shaped object) into each of the two small openings in the rear top corners of the cover. Insert screwdriver far enough to deflect spring latch. Pull up on each corner to release cover. (See Figure 4-2-1-1.)
2. Raise cover to approximately 60°. The U-shaped support rod inside the cover will detent, holding cover open.

##### To close the top cover:

1. Placing one hand on top cover to support it, gently pull the center of the U-shaped rod out of its detented position.
2. With both hands supporting the top cover, lower cover to drive frame. Press down to close.

##### To remove the top cover:

1. Open top cover and raise to detent position. (Cover supported by its U-shaped support rod.)
2. Supporting the weight of top cover, press inward on U-shaped rod and remove both ends of the rod (one at a time) from holes in the drive frame. (See Figure 4-2-1-1.)
3. Raise rod ends (one at a time) towards the upper (open) edge of the cover, clip them into the corner clips.
4. Holding the cover open, remove the bar hinge from one side of the base of the cover (pressing outward until it is released). Repeat this procedure to release the other hinge.
5. Remove top cover from drive.

##### To replace the top cover:

#### **NOTE**

Top cover should be placed in the same physical orientation, onto drive frame, as removed.

1. Position bottom edge of the top cover on the drive frame.

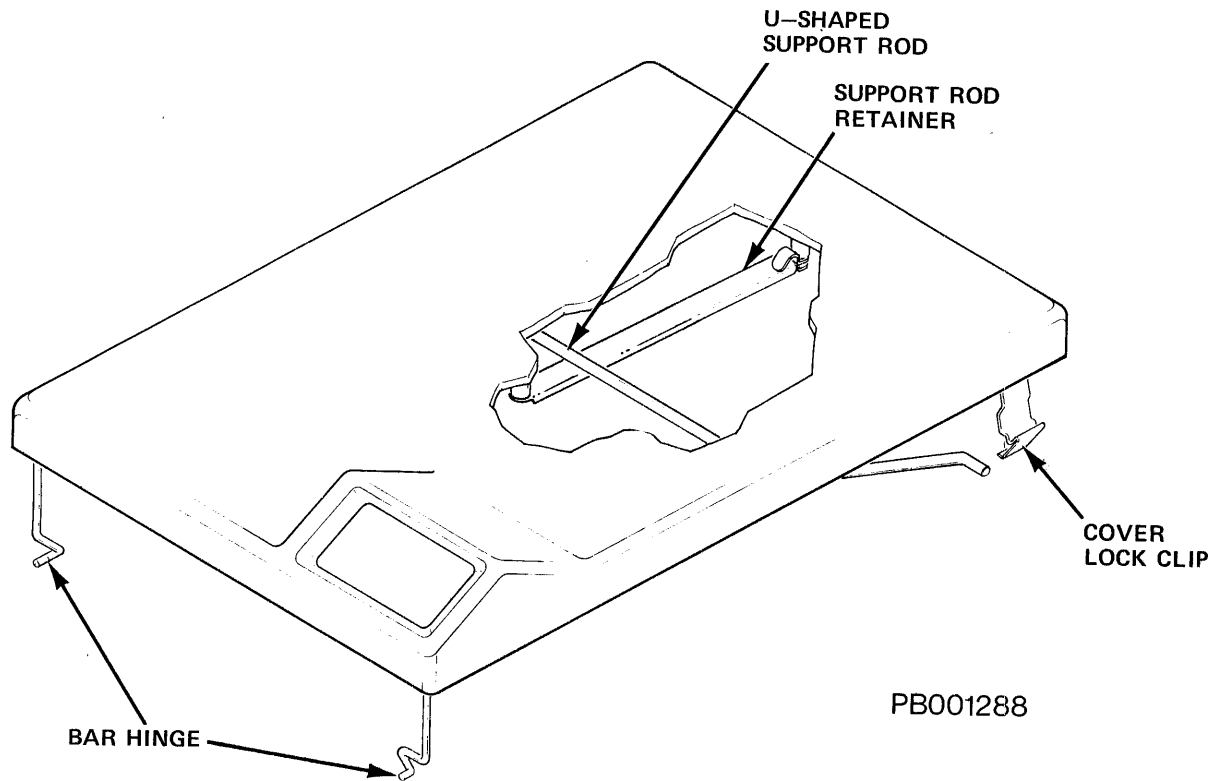

Figure 4-2-1-1 Top Cover Assembly

2. Supporting top cover with one hand, place each of the hinge bars into place, one at a time.
3. Supporting top cover with one hand, release the U-shaped support rod from each of the corner clips. Lower the rod ends and insert them into their holes in the drive frame one at a time.

**4.2.1.2 Front and Rear Cover Assemblies** - The front and rear covers (see Figure 4-2-2) are both hinged onto the drive frame. The front cover can be opened directly, but to open or remove the rear cover, the top cover must be opened first. The front and rear covers are identical in appearance, except that the logo (DIGITAL RP07) appears only on the front cover.

To remove the front cover:

1. Open the front cover by placing one hand under the edge of the top cover, at the right hand corner, and pull outward.
2. Lift cover upward to disengage it from the two hinges on the left hand side of drive frame.

To replace the front cover:

1. Set the cover hinges into their hinge slots on the left hand side of drive frame. Make sure the hinges are engaged.

2. Swing front cover closed. Press into locked position.

To remove the rear cover:

1. Open the top cover assembly and pull rear cover outward, to a 60° angle, from the drive.
2. Lift the cover upward to disengage it from the two hinges on the left hand side of frame.

To replace the rear cover:

**NOTE**

Top cover assembly must be opened to install rear cover assembly.

1. Set the cover hinges into their hinge slots on the left hand side of the drive frame. Make sure hinges are engaged.
2. Swing rear cover closed. Lock rear cover in place by closing the top cover assembly.

**4.2.1.3 Side Cover Assemblies** - The two side cover assemblies (see Figure 4-2-1-2) are identical. They are designed to allow the cables to exit from the bottom.

Before removing or installing the side covers, the top cover assembly must be opened or removed.

To remove side covers:

1. Loosen and remove two screws and lockwashers at the top corners of each side cover.
2. Lift side cover(s) up and off the drive frame.

To replace side covers:

1. Place each side cover(s) onto the side of the drive frame, hooking it into slots in the frame.
2. Install and tighten the two screws and lockwashers at the top corners of each side cover.

**4.2.2 Prefilter (P/N 9025523-00)**

The prefilter is a fiber type filter inserted in its housing in the Blower Assembly (A5). It traps the larger airborne particle contaminants, thus preventing them from circulating through the Electronics Library (A1) and the Absolute Filter (A6A5A1).

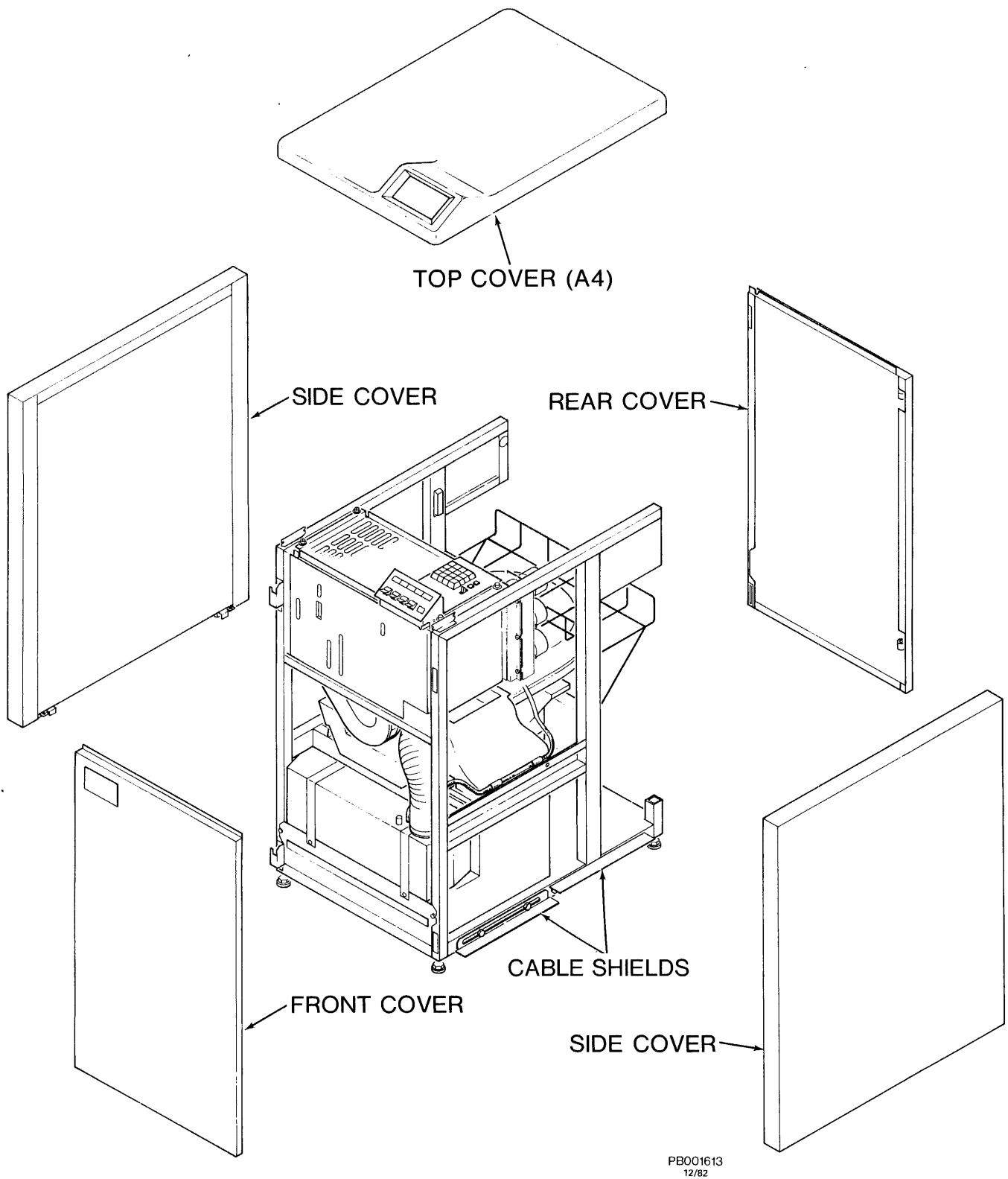

PB001613  
12/82

Figure 4-2-1-2 Drive Service Covers

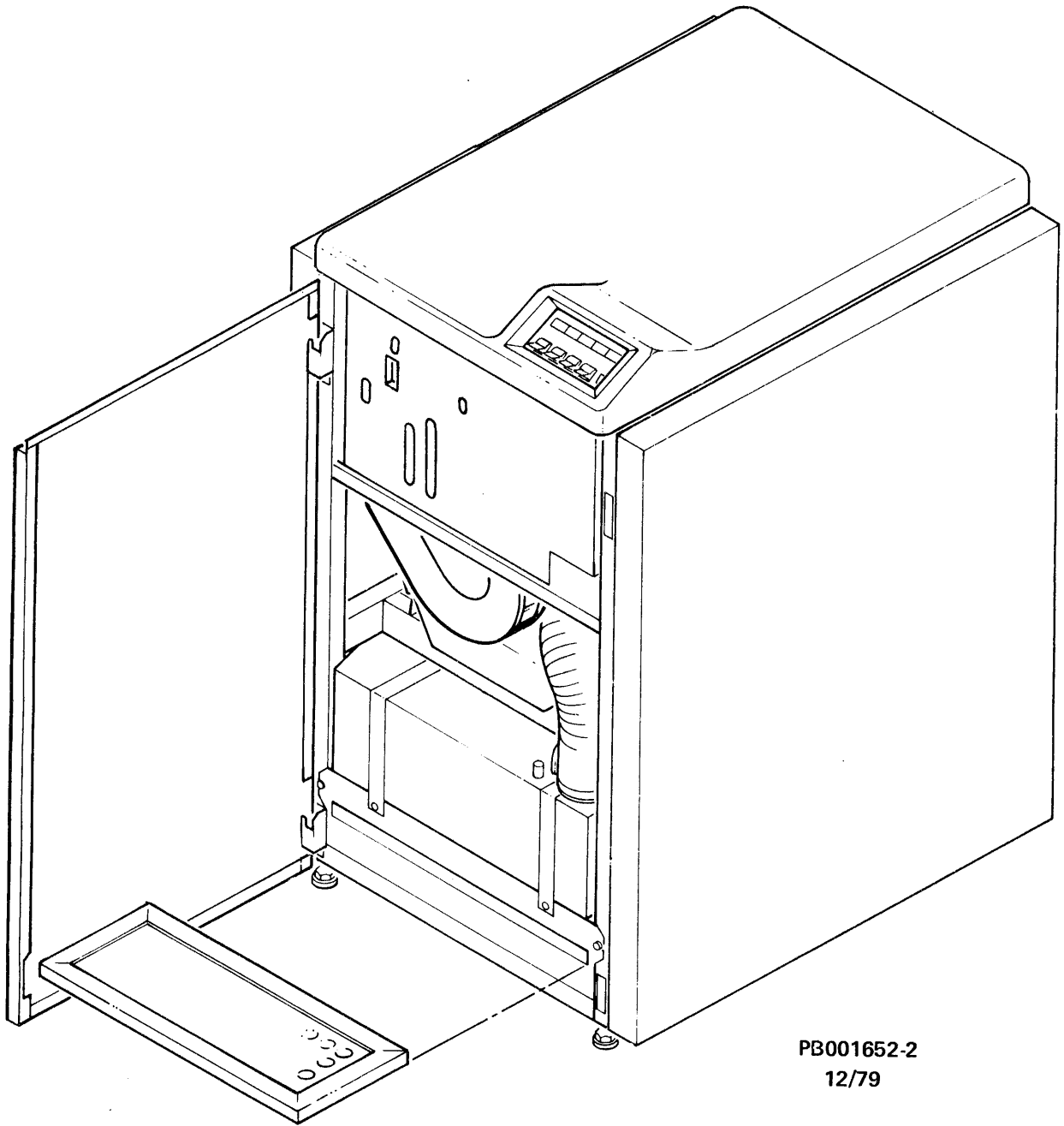

PB001652-2  
12/79

Figure 4-2-2 Prefilter Replacement

### **CAUTION**

DO NOT attempt to clean and reuse the prefilter or damage to the equipment may result. The prefilter is a throw away item and must be discarded after use.

#### To remove the Prefilter:

1. Obtain permission to disrupt customer operations. Place drive ONLINE/OFF-LINE switch OFFLINE.
2. Place START/STOP switch in the STOP position.
3. Open drive front door.
4. Remove the electronics library cover by loosening (DO NOT REMOVE) the two screws in the keyhole slots. Lift the library cover up and away from the drive.
5. Set the MASSBUS ENABLE/DISABLE switch to DISABLE (down).
6. Set the SERVICE switch OFF (down).
7. Set CBI OFF.
8. Slide existing Prefilter out of its housing in the blower assembly and discard it. See Figure 4-2-2.

#### To replace the Prefilter:

### **NOTE**

1. Handle the replacement prefilter with care. DO NOT use a replacement prefilter that is bent, broken or obviously damaged.
  2. Insure replacement prefilter is installed correctly, airflow arrow point up; prefilter slid all the way into its housing.
1. Slide the replacement prefilter into its housing in the blower assembly.
  2. At the rear of the drive set CBI ON. Close the drive rear door.
  3. Set the SERVICE switch ON (up).
  4. Set the MASSBUS ENABLE/DISABLE switch to ENABLE.
  5. Replace the electronics library cover by sliding the keyhole slots over the two screws. Tighten the two screws.
  6. Close the drive front door.

7. Place START/STOP switch in the START position.
8. Perform "Power On Start" Procedure.

#### 4.2.3 Absolute Filter (A5A1) (P/N 9025527-01)

The Absolute Filter (see Figure 4-2-3-A) is a 0.3 micron filter that provides 99.97 percent filtering efficiency of the pressurized air entering the HDA (A7) and EMA (A6A3A1) areas.

This procedure requires the following tools:

- Screwdriver
- Plastic Bag (small sandwich type)

To remove the Absolute Filter:

#### NOTE

Before removing the Absolute Filter, be sure to have a replacement filter ready for immediate installation.

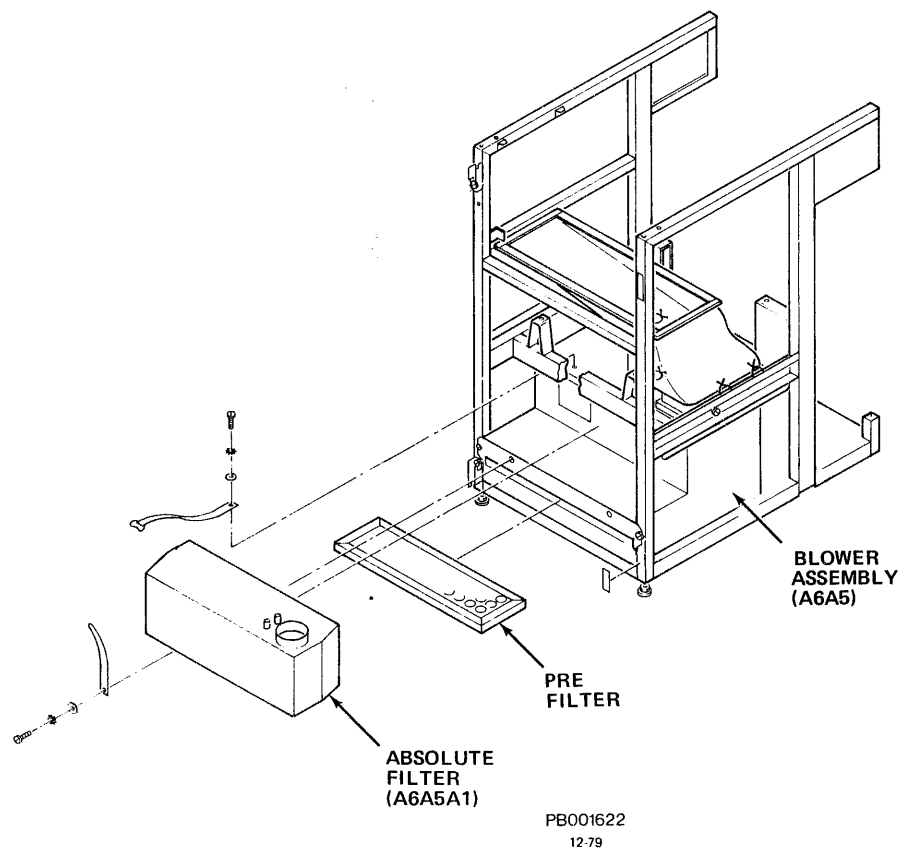

Figure 4-2-3-A Absolute Filter Replacement

### **CAUTION**

To protect replacement Absolute Filter from environmental contamination, DO NOT remove filter from its protective (sealed) plastic bag, and DO NOT remove the protective sealing caps from the filter until requested to do so in this procedure.

1. Obtain permission to disrupt customer operations. Place drive ONLINE/OFF-LINE switch OFFLINE.
2. Place START/STOP switch in the STOP position.
3. Open drive front door.
4. Remove the electronics library cover by loosening (DO NOT REMOVE) the two screws in the keyhole slots. Lift the library cover up and away from the drive.
5. Set the MASSBUS ENABLE/DISABLE switch to DISABLE (down).
6. Set the SERVICE switch OFF (down).
7. At the rear of the drive, raise top cover and open drive rear door.
8. Set CB3, CB2 and CB1 OFF in that order.
9. At the front of the drive remove the shield cover assembly by inserting a narrow pointed object (narrow blade screwdriver) into the hole in the upper center of the shield. By applying pressure, the retainer clip will release. Pull down on the shield and slide it out.
10. Unbuckle the old Absolute Filter retaining straps. (DO NOT remove the filter at this time.)

### **NOTE**

Insure floor in front of drive is clean; if necessary place filter on the plastic bag before placing filter on floor (Step 11).

11. Remove the replacement filter from its protective plastic bag. (DO NOT remove sealing caps.) Place the replacement filter on floor in front of the drive.

### **NOTE**

The Absolute Filter has two air pressure taps (see Figure 4-2-3-B). Follow Steps 12 and 13 to remove and install the (clear plastic) air hose tubing from the old filter onto the replacement filter. Be sure to



install the air hose (tubing) onto the innermost tap.

12. Remove cap from the innermost tap of replacement filter.
13. Immediately remove (clear plastic) air hose tubing from the old filter and install onto replacement filter.
14. Loosen (DO NOT remove) air hose clamp that secures the air hose to the absolute filter discharge opening.

**CAUTION**

The HDA air hose must be capped with a plastic bag (clean suitable material may be used), to prevent environmental contaminants from entering it.

15. Remove HDA air hose from old absolute filter and immediately cap hose with plastic bag.
16. Remove old absolute filter from Blower Assembly. Discard it.

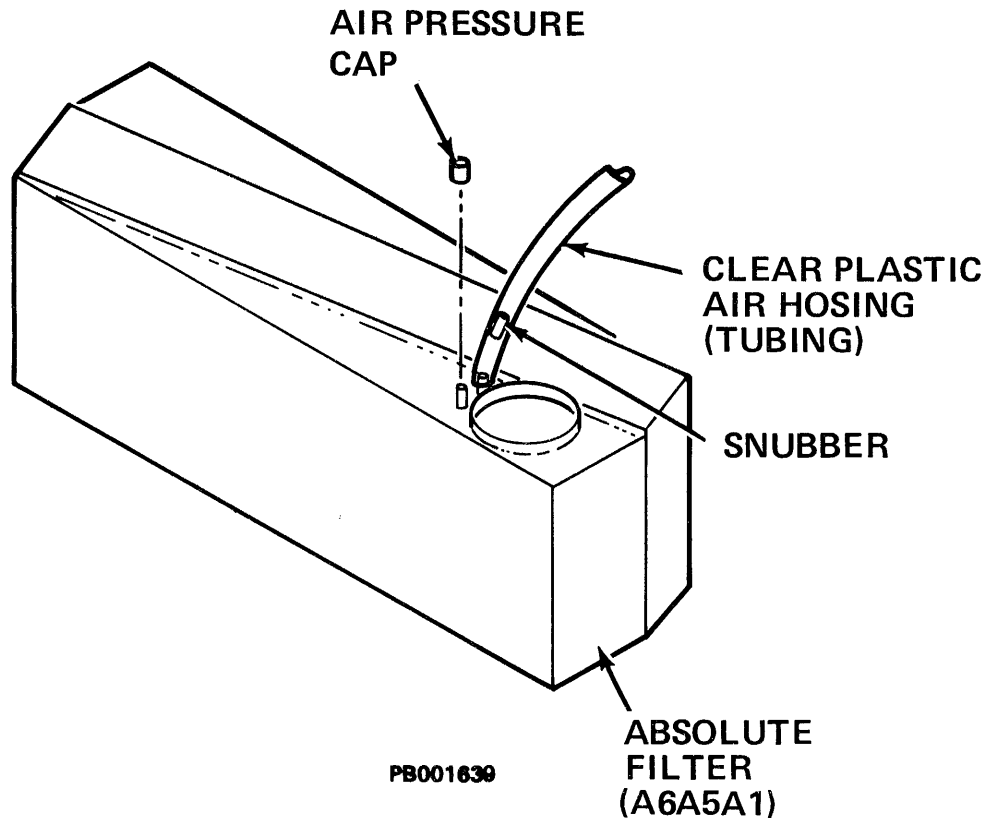

Figure 4-2-3-B Absolute Filter Air Pressure Taps

17. Remove protective seal from the intake opening of the replacement filter.
18. Place replacement filter into its housing in the blower assembly.
19. Remove protective seal from the discharge opening of replacement filter.
20. Immediately remove plastic bag from the air hose and install hose onto filter discharge opening.
21. Wrap air hose clamp around the base of the air hose. Tighten it to  $30 \pm$  lb/in with torquing tool.

**NOTE**

Be sure the replacement filter intake opening is aligned with the Blower Assembly outlet before proceeding.

22. Buckle absolute filter retaining straps. Pull retaining straps until filter is securely seated against blower housing.
23. Reposition air hose (if necessary) to keep hose from chaffing against any solid object (baseplate or frame).

**NOTE**

1. Whenever an Absolute Filter has been replaced, it is recommended that an air pressure check be performed to insure filter performance.
2. The following procedure provides the recommended method of taking air pressure measurements using the (optional) Air Pressure Gauge Assembly and Adapter Hose.

Air Pressure Check:

This procedure recommends the following tools:

- Air Pressure Gauge Assembly
  - Air Pressure Gauge Adapter Hose
1. With the START/STOP switch to STOP, set CBI ON.
  2. Remove the air pressure cap from the outermost air pressure tap, located on top of the Absolute Filter. (See Figure 4-2-3-B).
  3. Attach the Air Pressure Gauge Adapter Hose to the air pressure tap.

**NOTE**

Fitting end of Air Pressure Gauge Adapter Hose mates with the Air Pressure Gauge Assembly.

4. Connect the Air Pressure Gauge Assembly.
5. Record exhaust pressure.
6. Set CBI OFF.
7. Refer to Table 4-2-3, Air Pressure Records. The exhaust pressure of the replacement Absolute Filter should be at least that shown in the Air Pressure Records. If the exhaust pressure matches the air pressure records on Table 4-2-3, go to Step 8. If the exhaust pressure is less than shown, change the prefilter, (see Subsection 4.2.2 of this manual).

Table 4-2-3 Air Pressure Records

INSTALLATION ALTITUDE		MINIMUM BLOWER PRESSURE AT INSTALLATION INCHES/H <sub>2</sub> O	REPLACE FILTER BEFORE PRESSURE RECORDS INCHES/H <sub>2</sub> O
(FEET)	(METERS)		
0	0	2.50	2.10
1000	305	2.42	2.03
2000	610	2.35	1.97
3000	914	2.28	1.90
4000	1219	2.21	1.84
5000	1524	2.14	1.78
6000	1829	2.07	1.71
7000	2134	2.01	1.66
8000	2438	1.94	1.61
9000	2743	1.88	1.55
10000	3048	1.82	1.50

Installation Altitude \_\_\_\_\_

Installation Air Pressure \_\_\_\_\_

**NOTE**

After Prefilter replacement, record exhaust pressure. If exhaust pressure matches Table 4-2-3, go to Step 8.

8. Remove the Air Pressure Gauge Assembly and Adapter Hose from the air pressure tap.

9. Replace the cap on the Absolute Filter air pressure tap.
10. Replace the shield cover by sliding the lower portion of the shield over the lower horizontal frame member and lifting up until the upper edge of the shield containing the retainer clip latches with the upper horizontal frame member.
11. At the rear of the drive set CB1, CB2 and CB3 ON in that order. Close the drive rear door.
12. Set the SERVICE switch ON (up).
13. Set the MASSBUS ENABLE/DISABLE switch to ENABLE.
14. Replace the electronics library cover by sliding the keyhole slots over the two screws. Tighten the two screws.
15. Close the drive front door.
16. Place START/STOP switch in the START position.
17. Perform "Power On Start" Procedure.
18. Resume customer operations.

#### **4.2.4 Indicators (P/N 4912414-03)**

Indicators (see Figure 4-2-4) are located on the Operator Control Panel Assembly (A1A20) behind the Switch Panel Assembly. Lamp failures do not affect drive operation and lamps should be replaced only after failure.

This procedure requires the following tools:

- Removal/Inserter Tool (furnished with the drive and stored under the control panel cover.
  - Needle-nose pliers
1. Obtain permission to disrupt customer operations. Place drive ONLINE/OFFLINE switch OFFLINE.
  2. Place START/STOP switch in the STOP position.
  3. Open the drive front door.
  4. Remove the electronics library cover by loosening (DO NOT REMOVE) the two screws in the keyhole slots. Lift the library cover up and away from drive.
  5. Set the MASSBUS ENABLE/DISABLE switch to DISABLE (down).
  6. Set the SERVICE switch OFF.
  7. At the rear of the drive raise top cover to its detent position. Open drive rear cover.

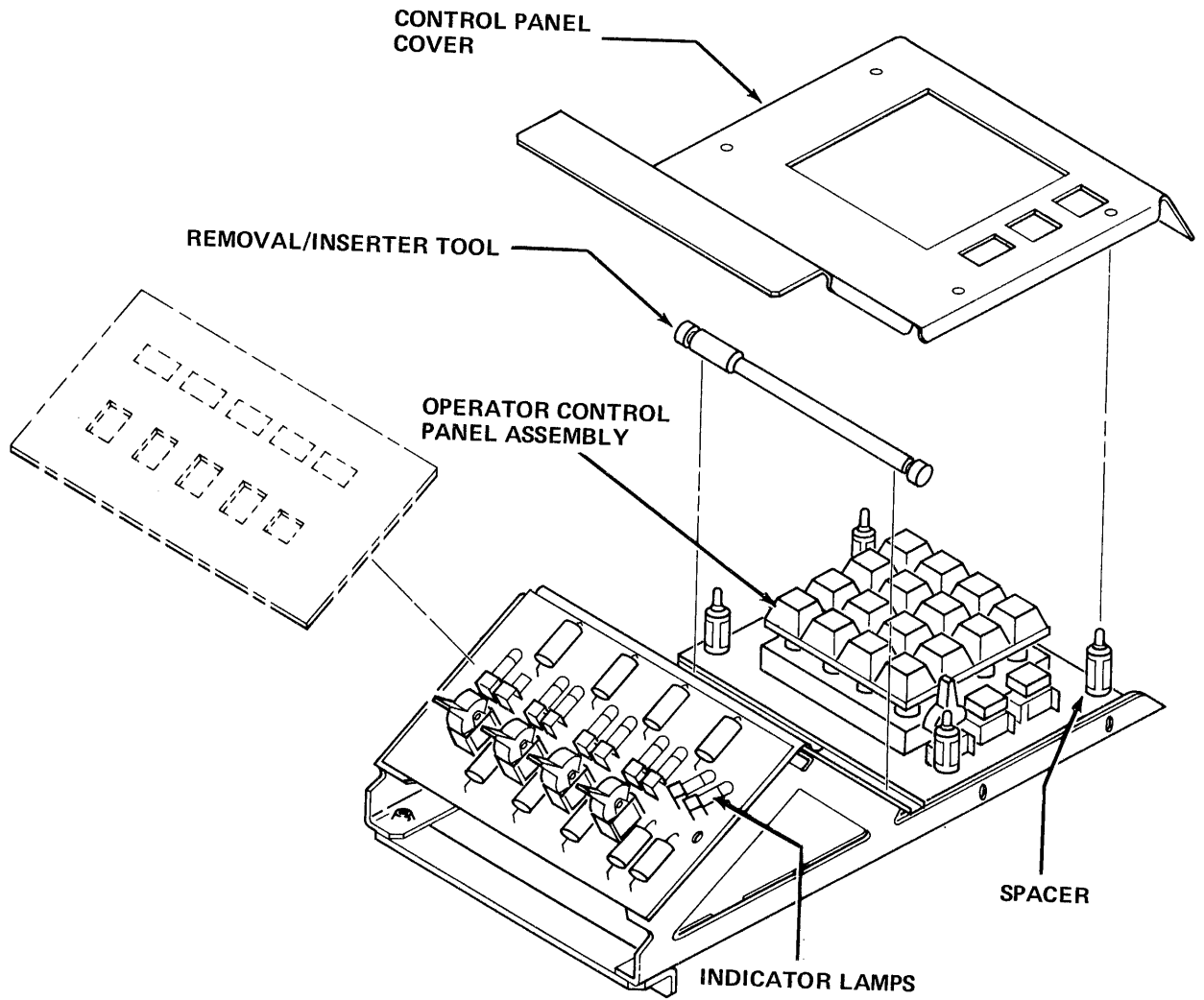

PB001601

Figure 4-2-4 Indicator Lamps

8. Set CB3, CB2 and CB1 OFF in that order.
9. With fingers or needle-nose pliers, pinch the four spacers, located near the four corners of the FE panel. Lift and remove control panel cover.

**NOTE**

Use the Removal/Inserter tool in Steps 10 and 13.

10. With plunger fully retracted, insert lamp tool sleeve over the defective lamp. With a quick jerk motion, pull lamp straight out. Remove lamp from the tool and discard lamp.
11. With plunger fully retracted, insert bulb portion of the replacement lamp into open end of lamp tool. (Approximately one-half of the bulb portion of lamp should be inserted into the tool.)
12. Slowly push tool plunger in until it touches the bulb.
13. Install replacement lamp into open receptacle. Push plunger in fully, causing lamp to be seated into its socket. (There should be an audible "click" and a feel of seating.)
14. Remove and store the lamp Removal/Inserter tool.
15. Replace control panel cover on the Control Panel Assembly. Be sure the four spacers and all switches are aligned with the control panel cover openings.
16. Apply firm pressure to the four corners of the control panel cover, until each spacer snaps through cover openings.
17. Set CB1, CB2 and CB3 ON in that order.
18. Close the drive top cover and the rear door.
19. Set the SERVICE switch ON.
20. Set the MASSBUS ENABLE/DISABLE switch to ENABLE.
21. Replace the electronics library cover by sliding the keyhole slots over the two screws. Tighten the two screws.
22. Close the drive front door.

**NOTE**

Full lamp illumination should occur (for approximately 15 seconds) when placing the SERVICE switch to the ON position (Step 19). CB2 should be ON.

23. Place START/STOP switch in the START position.

24. Resume customer operations.

#### 4.2.5 Electronics Library (A1) (P/N 9035518-03)

The following procedure describes the removal and replacement procedures of the Electronics Library (see Figure 4-2-5-A) with the Operator/FE Control Panel Assembly attached to it:

This procedure requires the following tool:

- Screwdriver
1. Obtain permission to disrupt customer operations. Place drive ONLINE/OFF-LINE switch OFFLINE.
  2. Place START/STOP switch in the STOP position.
  3. Open drive front door.
  4. Remove the electronics library cover by loosening (DO NOT REMOVE) the two screws in the keyhole slots. Lift the library cover up and away from the drive.
  5. Set the MASSBUS ENABLE/DISABLE switch to DISABLE (down).
  6. Set the SERVICE switch OFF.
  7. At the rear of the drive, open and remove drive top cover. Open drive rear door.

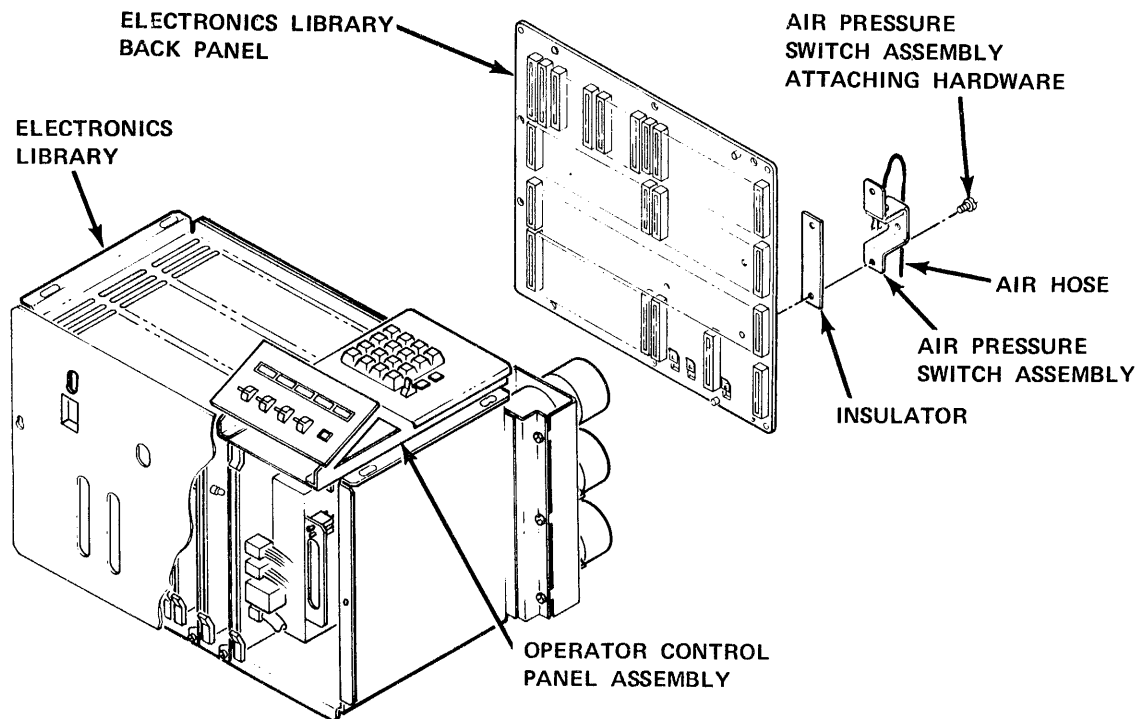

Figure 4-2-5-A Electronics Library

PB001631-3  
4-80

8. Set CB3, CB2 and CB1 OFF in that order.

**NOTE**

Label and mark each ribbon cable connector connected to the electronics library backpanel with its backpanel and pin location, before removing them from the backpanel (Step 9).

9. Label and disconnect the ribbon cable connectors from rows B, C and D from the electronics library backpanel. Rows are lettered on the right side of the backpanel. (DO NOT disconnect ribbon cable connector from cable tray.)
10. Label and disconnect the HDA ribbon cable and its ground strap from E4 backpanel screw. Label and disconnect the HDA ground strap from (left side) backpanel screw.
11. Loosen screws on E1, E2 and E3 terminals (located on the lower left hand corner of the backpanel). Label and disconnect wires from E1, E2 and E3 terminals.
12. Remove the (clear plastic) air hose tubing from the air pressure switch. See Figure 4-2-5-B.

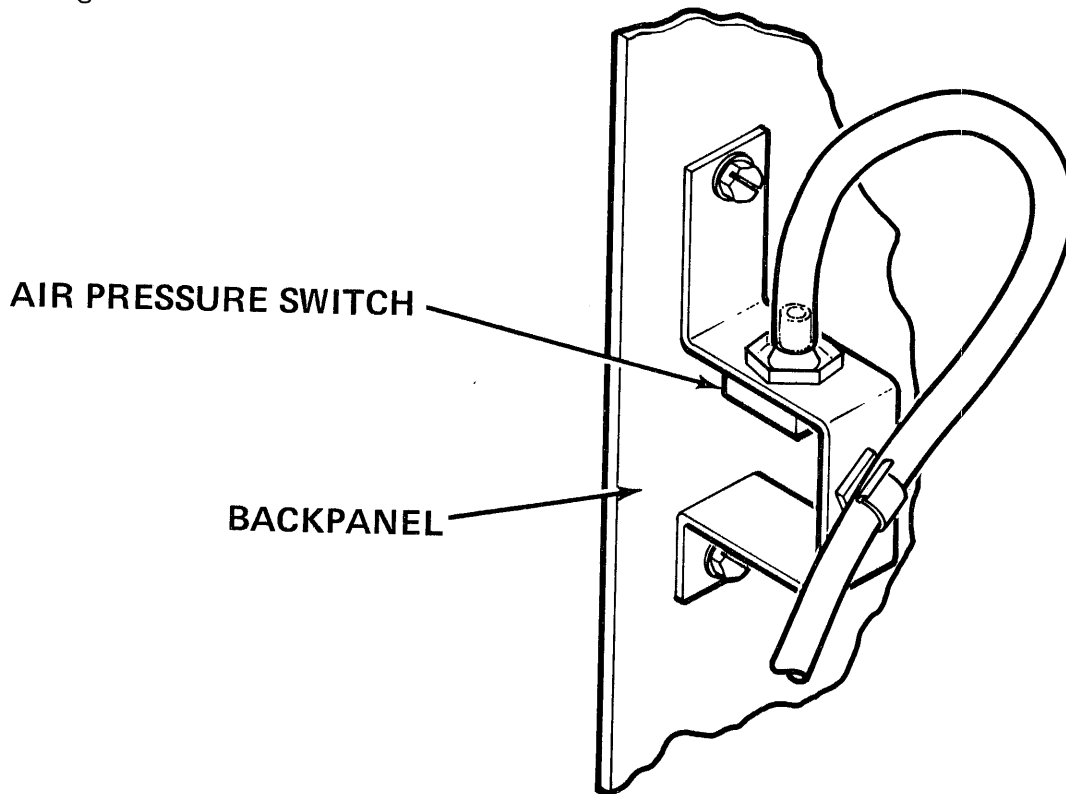

PB001640-2

Figure 4-2-5-B Air Pressure Switch



**NOTE**

The air pressure switch is mounted to a bracket on the electronics library backpanel.

13. Carefully pull the (clear plastic) air hose (tubing) down and out of its retaining clip.

**NOTE**

The retaining clip is fastened to the air pressure switch bracket.

14. Loosen and remove two self-tapping screws and lockwashers located at the lower front end of the Control Panel Assembly.
15. Loosen and remove the self-tapping screws and lockwashers located at the back end of the Control Panel Assembly.
16. Holding the ribbon cable away from the backpanel pins and wires, lift the Control Panel Assembly up and off the top of the drive.

**NOTE**

Before the electronics library can be removed from the drive, the Rectifier Assembly PCA (A1A1) and Capacitor Assembly PCA (A1A21) must be removed first.

17. Disconnect three (3) plug connectors located at J1, J2 and J3 on Capacitor Assembly (A1A21). Disconnect plug connector from Capacitor Assembly (A1A21) located near CB2 backpanel side of electronics library.

**WARNING**

DO NOT touch components on PCA A1A1 or Capacitor Assembly A1A21. They may be hot and personal injury may result.

18. To remove the Rectifier Assembly PCA A1A1, simultaneously grasp PCA upper and lower plastic extraction tabs. Pull upper plastic tap up, lower plastic tab down. The Rectifier Assembly is now released from its backpanel connector.
19. Carefully slide the Rectifier Assembly PCA (A1A1) straight out of the library, supporting its weight with flat side of one hand (palm) under the assembly. Carefully set it aside.
20. Loosen and remove two screws from lower edge of capacitor mounting bracket.
21. At the rear of the drive, loosen and remove one screw from top left hand corner of Capacitor Assembly (A1A21) mounting bracket.

### **CAUTION**

1. Take care when removing the Capacitor Assembly. DO NOT drop Capacitor Assembly onto the HDA. Damage to the HDA casing could result.
  2. DO NOT carelessly pull this assembly out of the library. Damage to the (clear plastic) air hose, backpanel wires, pins or connectors could result.
22. Carefully and slowly pull the Capacitor Assembly (A1A21) out of the electronics library, turning it toward the right side of drive until capacitors clear library cage and cable tray. Carefully set it aside.
  23. Loosen and remove four screws and lockwashers located on top corners of the library cage.
  24. Loosen and remove two screws and lockwashers located on lower right and left hand corners of the library cage.

### **NOTE**

Removing the screw and lockwasher on the lower right hand corner of library cage releases a looped cable tie that secures three internal harnesses to the library cage.

### **CAUTION**

1. Avoid holding onto or damaging backpanel pins while lifting and removing the electronics library from drive frame.
2. DO NOT TILT library cage forward. PCAs not fully inserted may slide out of the library and become damaged.

### **WARNING**

A fully loaded library will weigh approximately 18 kg (40 pounds).

25. Grasp the electronics library at front top and back bottom. Lift it up and out of drive frame.

For replacement of the electronics library, PCA A1A1, and Capacitor Assembly A2A21, reverse the removal steps. Visually verify that all ribbon cable connectors and plug connectors are reconnected and properly seated. **VERIFY THAT HDA GROUND STRAPS ARE RECONNECTED.**

After replacement of the electronics library restore AC power to the drive as follows: Set CB1 ON, place CB2, CB3 and SERVICE switch ON. Perform "Power On Start" Procedure. Resume customer operations.

#### **4.2.6 Printed Circuit Assemblies (PCAs)**

The RP07 Electronics Library (A1) contains 17 PCAs (see Figure 4-2-6). Seven PCAs contain static sensitive IC MOS devices. These PCAs are: A4, A7, A8, A14, A15, A16, and A17.

#### **CAUTION**

PCAs containing static sensitive IC MOS devices are susceptible to electro-static discharge (ESD) damage when improperly handled. **SPECIFIC PRECAUTIONS** must be taken to avoid failure of a component(s) by ESD. Before handling a PCA with static sensitive IC MOS devices, see Subsection 1.5.3.4 of this manual.

The following procedure is for the removal of PCAs A1A2 thru A1A17 ONLY. For the removal and replacement of PCA A1A1 and the Capacitor Assembly A1A21, see Subsection 4.2.6.1 and 4.2.6.2 of this manual.

1. Obtain permission to disrupt customer operations. Place drive ONLINE/OFFLINE switch OFFLINE.
2. Place START/STOP switch in the STOP position.
3. Open drive front cover.
4. Loosen (DO NOT REMOVE) two screws in the keyhole slots that secure the library cover to the library cage.
5. Lift library cover up and away from drive.

#### **WARNING**

DO NOT touch components on removed PCAs. They may be hot and personal injury may result.



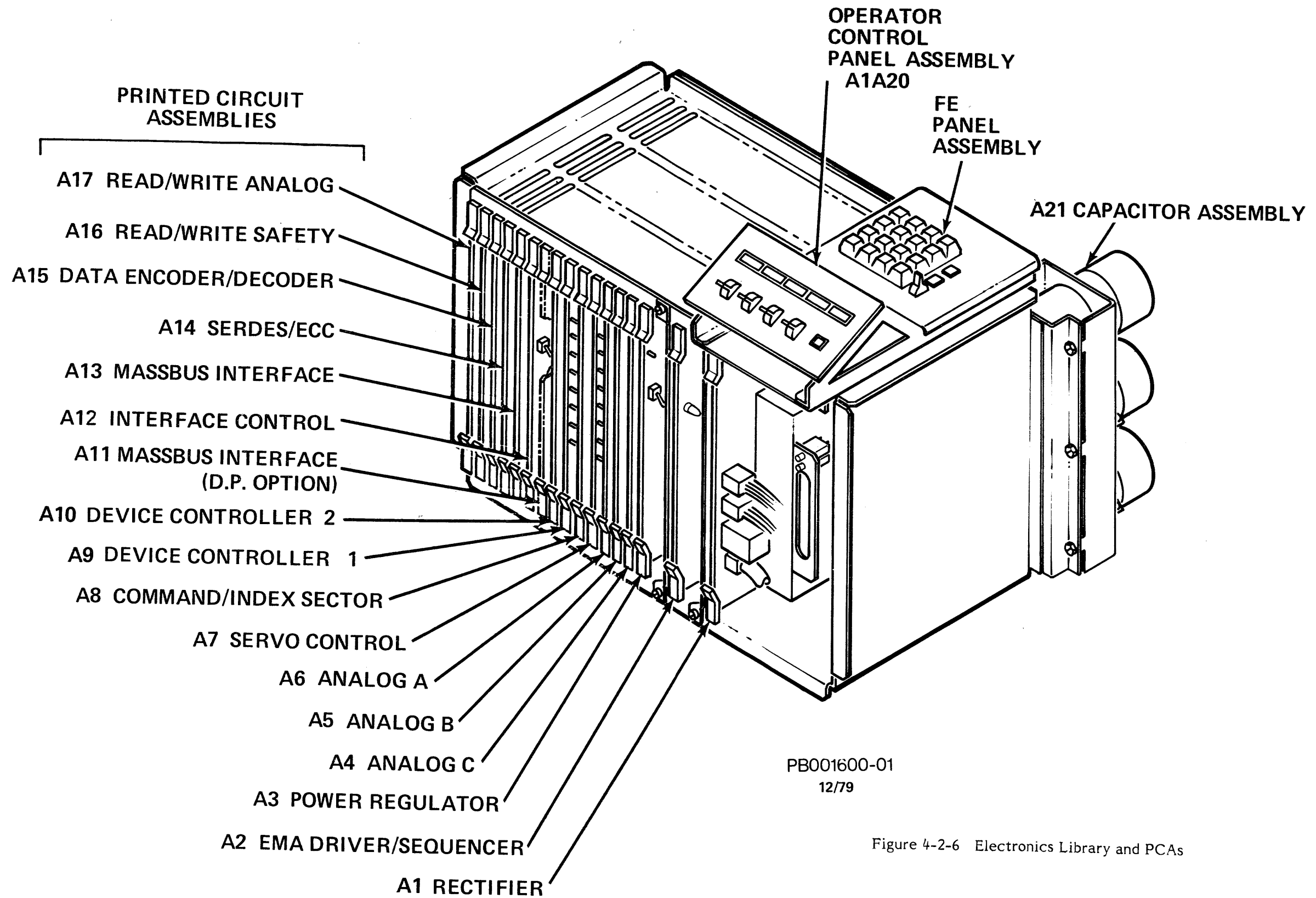

Figure 4-2-6 Electronics Library and PCAs

#### **NOTE**

1. For the removal of the PCAs A1A2 and/or A1A3 perform Steps 6, 8 and 9.
  2. For the removal of PCAs A1A4 through A1A17 perform Steps 7, 8 and 9.
6. Place CB3, CB2 and CB1 OFF in that order.

#### **WARNING**

To avoid personnel injury and/or damage to the equipment CB2, CB3 and CB1 must be OFF whenever removing PCAs A1A2 or A1A3.

7. Place SERVICE switch (A1A3) OFF.

#### **WARNING**

To avoid personal injury and/or damage to the equipment, the SERVICE switch (A1A3) must be OFF whenever removing PCAs A1A4 through A1A17.

8. Simultaneously grasp upper and lower plastic extraction tabs. Pull upper plastic tab up, and lower plastic tab down. (The PCA is now released from its backpanel connector.)
9. Carefully slide the PCA out of the library, supporting its weight with the flat side of one hand (palm) under the PCA. (This will prevent the connector end of the PCA from being damaged during removal.)

#### **PCA Replacement:**

Replace PCAs A1A2 thru A1A17 by reversing the removal steps. To lock PCA(s) into place:

#### **CAUTION**

PCAs must be installed into the library correctly or damage may result. Install PCAs with plastic tab indicating PCA slot location on top of PCA.

1. Place PCA into the library (between guides, touching the backpanel mating connector).

2. With firm pressure at two points, press on the PCA board edge (not on the plastic extractors). (An audible "click" will occur when the PCA is firmly seated.)

To restore AC power to the drive:

Set CB1, CB2, CB3 and SERVICE switch ON.

Perform "Power On Start" Procedure. Resume customer operations.

**4.2.6.1 Rectifier Assembly PCA (A1A1)** - The following procedure describes the removal and replacement of the Rectifier Assembly PCA from the electronics library (A1). (See Figure 4-2-6.)

**WARNING**

DO NOT touch components on this assembly. They may be hot. Personal injury may result.

This procedure requires the following tool:

- Screwdriver
1. Obtain permission to disrupt customer operations. Place drive ONLINE/OFF-LINE switch OFFLINE.
  2. Place START/STOP switch in the STOP position.
  3. Open drive top and rear covers.
  4. Set CB3, CB2 and CB1 OFF in that order.
  5. Disconnect plug connector from Capacitor Assembly (A1A21) located near CB2 on the backpanel side of the electronics library.
  6. Open drive front cover.
  7. Loosen (DO NOT REMOVE) two screws in keyhole slots that secure library cover to the library cage. Lift library cover up and away from drive.
  8. Disconnect plug connectors at J1, J2 and J3 from Rectifier Assembly (A1A1).
  9. Simultaneously grasp upper and lower plastic extraction tabs. Pull upper plastic tab up, lower plastic tab down. (The Rectifier Assembly PCA is now released from its backpanel connector.)
  10. Carefully slide with Rectifier Assembly PCA out of the library, supporting its weight with flat side of one hand (palm) under assembly.

### Rectifier Assembly PCA Replacement:

Replace Rectifier Assembly PCA by reversing the removal procedure. To lock Rectifier Assembly PCA into place:

1. Press on PCA board edge (not on the plastic extractors). (An audible "click" will occur when the Rectifier Assembly PCA is firmly seated.)
2. Be sure to reconnect the plug connectors removed in Steps 5 and 8.

### To restore AC power to the drive:

Set CB1, CB2, CB3, and SERVICE switch ON in that order.

Perform "Power On Start" procedure. Resume customer operations.

**4.2.6.2 Capacitor Assembly (A1A21)** - Before the Capacitor Assembly can be removed from the drive, the Rectifier Assembly PCA (A1A1) must be removed first. The following procedure describes the removal and replacement of the Rectifier Assembly PCA and the Capacitor Assembly. (See Figure 4-2-6.)

#### **WARNING**

DO NOT touch components on these assemblies. They may be hot and personal injury may result.

This procedure requires the following tool:

- Screwdriver
1. Obtain permission to disrupt customer operations. Place drive ONLINE/OFF-LINE switch OFFLINE.
  2. Place START/STOP switch in the STOP position.
  3. Open drive top and rear covers.
  4. Set CB3, CB2, and CB1 OFF in that order.
  5. Disconnect plug connector from Capacitor Assembly (A1A21) located near CB2 on the backpanel side of the electronics library.
  6. Open drive front cover.
  7. Loosen (DO NOT REMOVE) two screws in keyhole slots that secure library cover to the library cage. Lift library cover up and away from drive.
  8. Disconnect plug connectors at J1, J2 and J3 from Rectifier Assembly (A1A1).
  9. Simultaneously grasp upper and lower plastic extraction tabs. Pull upper plastic tab up, lower plastic tab down. (The Rectifier Assembly PCA is now released from its backpanel connector.)



10. Carefully slide with Rectifier Assembly PCA straight out of the library, supporting its weight with flat side of one hand (palm) under assembly. Carefully set it aside.
11. At the rear of the drive, loosen and remove one screw from top left hand corner of capacitor mounting bracket.
12. Loosen and remove two screws from lower edge of capacitor mounting bracket.

#### **CAUTION**

1. Take care when removing this assembly. DO NOT drop Capacitor Assembly onto the HDA. Damage to HDA casing may result.
  2. DO NOT carelessly pull this assembly out of the library. Damage to the (clear plastic) air pressure hose, backpanel wires, pins or connectors could result.
- 
13. Carefully and slowly pull the Capacitor Assembly out of the electronics library, turning it toward the right side of drive until the capacitors clear library cage and cable tray.

#### Capacitor Assembly and Rectifier Assembly PCA Replacement:

Replace the Capacitor Assembly and Rectifier Assembly PCA by reversing the removal procedure. To lock Rectifier Assembly PCA into place:

1. Press on the PCA board edge (not on the plastic extractors.) (An audible "click" will occur when the Rectifier Assembly is firmly seated.)
2. Be sure to reconnect all plug connectors removed in Steps 5 and 8 of the removal procedure.

#### To restore AC power to the drive:

Set CB1, CB2 and CB3 ON.

Perform "Power On Start" Procedure.

**4.2.6.3 Pluggable Component Replacement** - The pluggable IC MOS devices used on RP07 PCAs are highly susceptible to electrostatic discharge (ESD) damage when improperly handled. To minimize ESD damage, see Subsection 1.5.3.4 of this manual whenever removing and replacing static sensitive PCAs for pluggable component replacement.

#### 4.2.7 Electronics Library Backpanel Contact Pin Replacement

Backpanel contact pin replacement is NOT recommended. See Subsection 4.2.5 of this manual, Electronics Library Replacement, when necessary.

#### 4.2.8 Head Disk Assembly (A7)

HDA Removal and Replacement Procedure:

This procedure requires the following tools:

- VOM/1.5 volt DC battery
- Plastic tie wrap, or minimum 6" length of stout cord, tied in a loop
- Screwdriver
- 1/2-inch open end or box wrench; 3/16-inch hex wrench; and an adjustable crescent wrench
- Tape (electrical tape preferred)
- Air Nozzle Cap
- Coil Dust Cap
- Vise Grips
- "John Ichi Torque Wrench", Model 00655Q (or equivalent) 5/16" socket, 1" long and 1/4" drive

#### CAUTION

The flying height of the heads is so small that any contaminants or shock and vibration may cause HDA damage. (See Figure 4-2-8-A.)

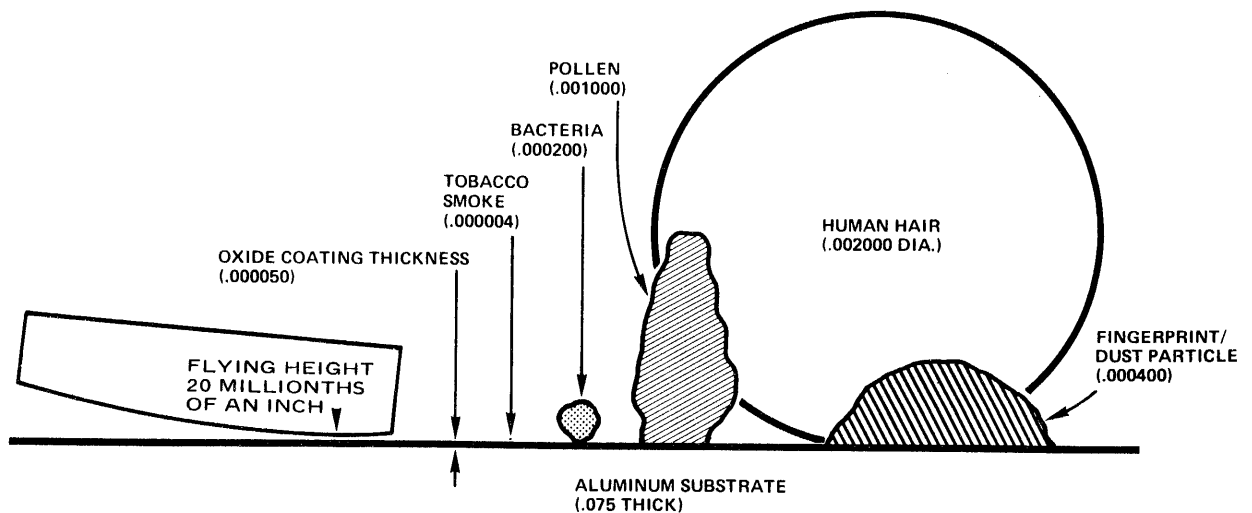

Figure 4-2-8-A Flight Height Versus Contaminants

## Unpackaging Replacement HDA:

Replacement HDAs are available in two different configurations.

- Sealed IDM HDA Partial Kit, P/N A9035663-02. This kit contains the HDA, 2 clamps, 2 gaskets and an EMA Filter. It should be used when the Total HDA Replacement Kit has already been installed - which is denoted on the Unit FCO Label with "X" through number "062". (See Figure 4-2-8-B1.)
- Sealed IDM HDA Total Kit, P/N A9049935-02. This kit should be used with the partial kit, for drives WITHOUT FCO "062" marked off on the Unit FCO Label. This kit contains an Absolute Filter, an air hose, 2 hose seals, and mounting hardware (for the EMA Filter). (See Figure 4-2-8-B2.)

### **CAUTION**

Use extreme caution when unpacking the HDA. Use as little movement as possible to avoid damage. Replacement HDAs are shipped in specially designed packaging containers to protect them from environmental contamination, shock and vibration. (See Figure 4-2-8-B).

1. Cut straps and remove tape that seals container.

### **NOTE**

Save all packaging material with the exception of the desiccant package and poly bag. They will be used to repackage the defective HDA.

2. Open container and remove the top inner molded foam. Place foam nearby as it will be used as a cushion for the removed HDA, Step 3. Place foam with small circular cavity facing up.

### **CAUTION**

DO NOT drop, turn upside down, or tilt the HDA or damage to the HDA stack or heads may result.

### **NOTE**

The HDA is encased in two bags, a heavy mil poly bag (containing the HDA and desiccant bag) and a barrier bag (outer bag) over the poly bag. Both bags protect the HDA against environmental contamination.

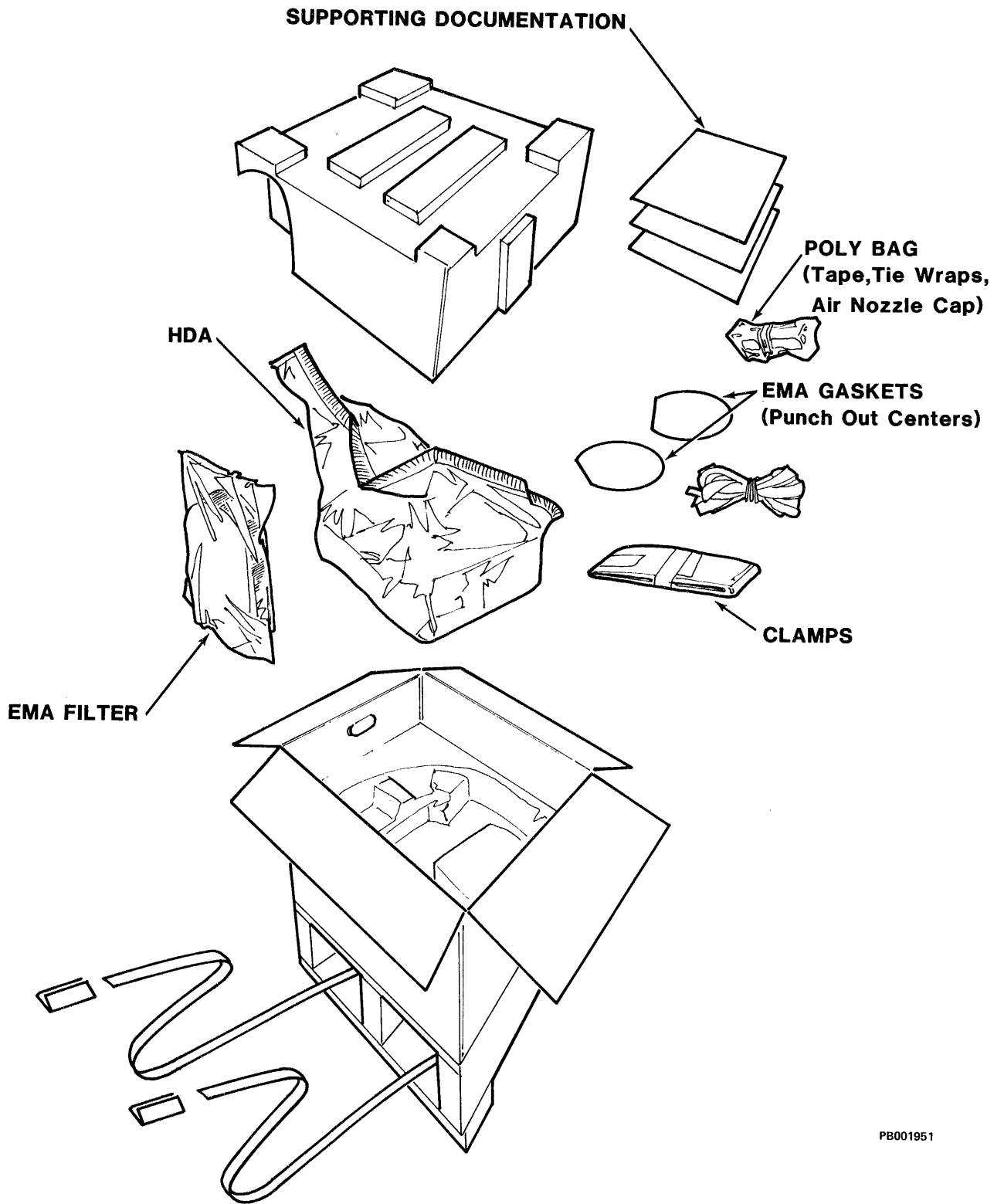

PB001951

Figure 4-2-8-B1 Replacement HDA Packaging - Partial Kit

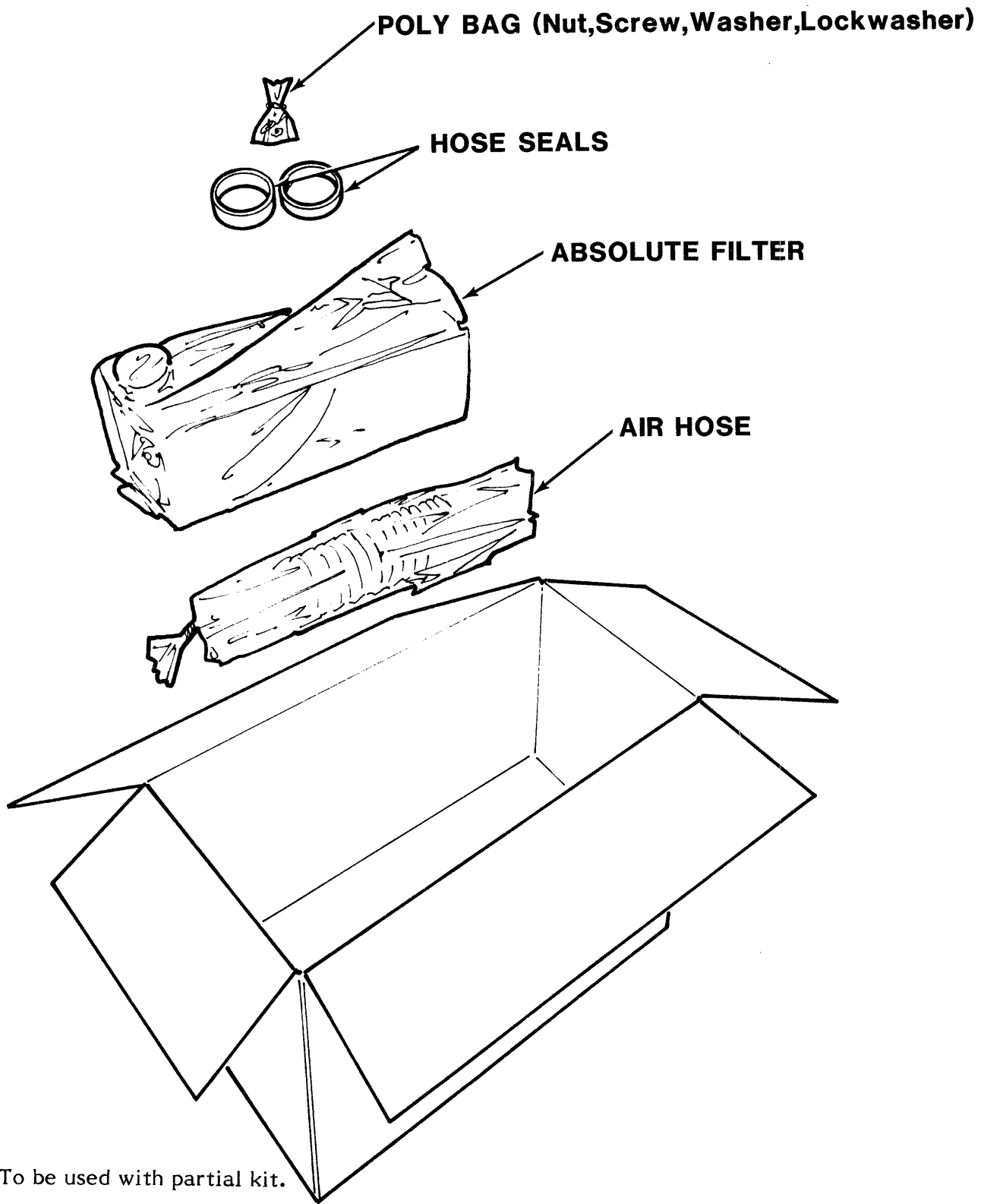

Figure 4-2-8-B2 Replacement HDA Packaging\*

3. Carefully cut open the heat-sealed end of the barrier bag. Unfold the inner pink polybag and **immediately** check the humidity indicator attached to the matrix cable guard. If the humidity is between 80 - 100 percent, report this to local Technical Support personnel. Proceed with installation.
4. Remove the HDA from bag and place it on foam pad. Remove spindle brake from bottom of HDA while it is on foam pad as follows:

#### Spindle Brake Removal

##### **NOTE**

A spindle brake (bracket) is attached to the bottom of the "Replacement HDA". This brake must be removed before installing the "Replacement HDA".

- a. Carefully locate replacement HDA on its side on the top cushion. Note that the brake is secured to the HDA via 2 of the 8 threaded holes used to attach the bottom cover of the HDA to the spindle casting. The 2 screws used to fasten the brake to the HDA are captive and must always be used with the brake. Observe the relative position of the two screws. Gently lower the replacement HDA to a horizontal position on the cushion.

##### **CAUTION**

From this point on in the procedure both HDAs are vulnerable to damage caused by either:

1. Clockwise rotation of the spindle/stack within the HDA housing.
  2. Counterclockwise rotation of the HDA housing around the spindle/stack. Be careful not to allow either to occur.
- b. Place the "Removed HDA" on the bottom cushion. Keeping a screwdriver handy carefully tilt the "Removed HDA" on its side. Remove the two screws which are in the same position respective to the two screws noted on the "Replacement HDA". Gently lower the HDA to a horizontal position on the cushion.
  - c. Keeping the screwdriver and the two screws handy carefully tilt the "Replacement HDA" on its side. Using the screwdriver remove the brake bracket. Install the two screws removed from the "Removed HDA". Avoid rocking the HDA when applying a sufficient amount of torque to the screws to prevent them from coming loose during drive operations. Gently lower the HDA to a horizontal position on the cushion.

- d. Carefully tilt the "Removed HDA" on its side and attach the brake to it via the now available two threaded holes. The spindle brake will be removed again at the factory, therefore avoid excessive torque when fastening the brake to the HDA. Gently lower the HDA to a horizontal position on the cushion.
5. Remove the Matrix Cable Guard Assembly as follows:
    - a. Unclip the top portion of the cover by applying upward force to the top tab of the cover.
    - b. Pivot the cover back over the side of the HDA. Remove the cover.
    - c. Unclip the top tab from behind the faceplate and pivot the guard over the top of the HDA. Remove the guard.
  6. Remove the bottom foam pad and bags from the carton. Set the foam pad nearby as it will be used as a cushion for the removed HDA.

#### **CAUTION**

1. DO NOT remove the Coil Dust Cap or the Air Nozzle Cap from the replacement HDA at this time. It protects the HDA from environmental contamination. Damage to the HDA, stack, or heads may result if cap is removed before requested to do so. (See Figure 4-2-8-C.)
2. DO NOT remove the spare Air Nozzle Cap from its container (small plastic bag) until requested to do so in this procedure. (See Figure 4-2-8-C.)

#### HDA Removal:

1. Obtain permission to disrupt customer operations. Place drive ONLINE/OFF-LINE switch OFFLINE. Place START/STOP switch to STOP.
2. Open drive top cover to its detent position; open drive front and rear doors. Remove the electronics library cover by loosening (DO NOT REMOVE) two screws in keyhole slots. Lift library cover up and away from drive.
3. Set MASSBUS ENABLE/DISABLE switch to DISABLE (down).
4. Set SERVICE switch to OFF.
5. Set CB3, CB2 and CB1 OFF in that order.

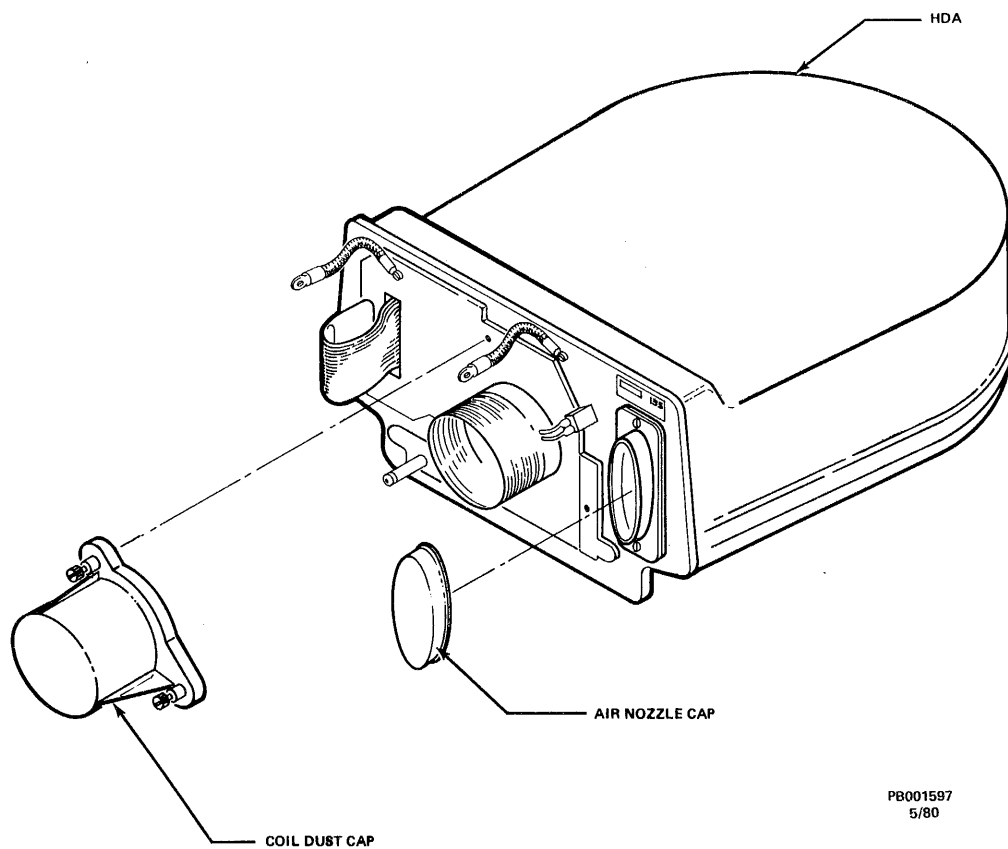

PB001597  
5/80

Figure 4-2-8-C HDA (Coil and Air Nozzle Dust Caps)

**NOTE**

Before disconnecting E1 and E2 EMA leads in Step 6, label and mark each lead with its reference designation. This will insure reinstalling E1 and E2 EMA leads in the exact physical orientation as removed.

6. At the rear of the drive, disconnect EMA leads E1 and E2 from the backpanel or battery pack if applicable.
7. Set CB1 ON. Set CB3 ON. Set SERVICE switch ON.
8. Place the FE LOCAL/NORMAL switch to LOCAL.
9. Enter 'FE' into the FE panel keyboard. Depress ENTER/STEP switch.
10. Enter '3E' into the FE panel keyboard. Depress ENTER/STEP switch.
11. Enter '11' into FE panel keyboard. Depress ENTER/STEP switch.
12. Wait for stack to come up to speed.



13. Connect a VOM/1.5 volt DC battery across E1 and E2 EMA leads. Use Ohms RX1 scale on VOM.

**NOTE**

Verify that carriage moves towards spindle. If the carriage does not move toward spindle, reverse leads. Tape leads to VOM/battery.

14. At the front of the drive, remove the shield cover assembly by inserting a narrow pointed object (narrow-blade screwdriver) into the hole in the upper center of the shield. By applying pressure downward, the retainer clip will release. Pull down on the shield and slide it out. Remove EMA dust cap (or filter) by turning it in a counterclockwise direction (old-style dust cap) or by removing the screw and lifting it off (new-style filter).
15. Loosen crash stop nut and turn crash stop indicator arm to the "HDA REMOVAL" position. (See Figure 4-2-8-D.)

**NOTE**

Turning crash stop indicator arm to the "HDA REMOVAL" position allows the carriage to move an additional one-half inch toward the spindle.

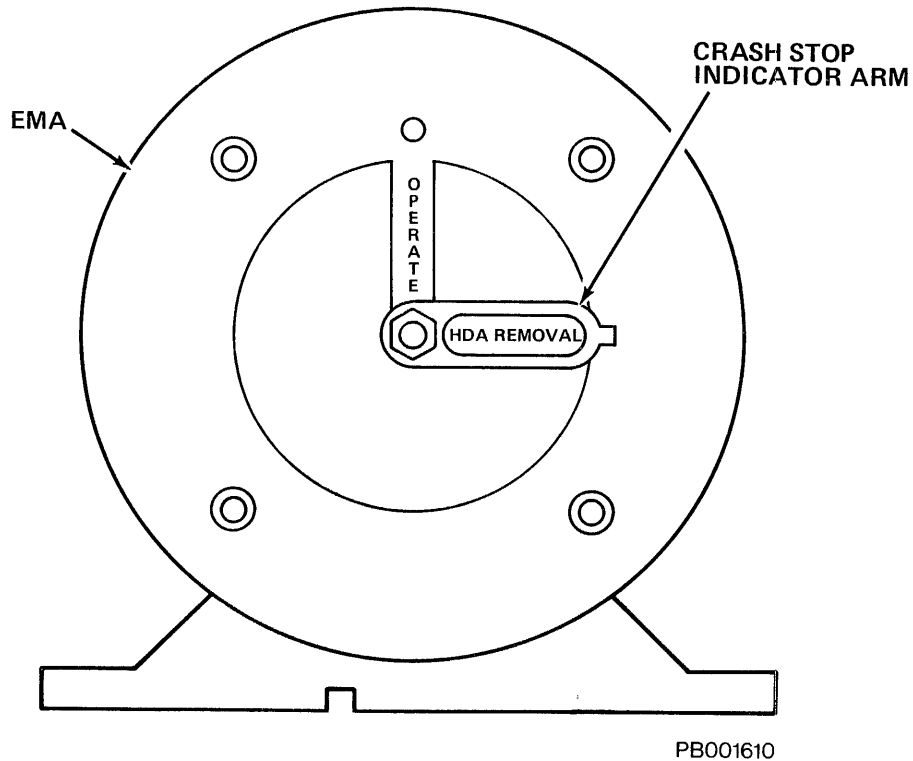

Figure 4-2-8-D EMA Crash Stop Indicator Arm

16. Enter ~~3F~~ into FE panel keyboard. Depress ENTER/STEP switch. **USE SERVICE SWITCH INSTEAD. TO POWER DOWN**
17. When stack stops spinning, set the SERVICE switch, CB3 and CB1 OFF in that order.

If installing a **"Total Sealed HDA Kit"** - which includes a HDA, 2 clamps, 2 gaskets, EMA Filter, plus the Absolute Filter, air hose, 2 hose seals and mounting hardware for the EMA - use Steps 19 thru 86.

If installing a **"Partial Sealed HDA Kit"** - which includes only the HDA, 2 clamps, 2 gaskets and EMA Filter, use Steps 87 thru 145.

18. At the rear of the drive, remove belt guard and belt extension spring. (A looped tie wrap or cord can be used to pull belt extension spring off the back stud.) See Figure 4-2-8-E.
19. At the front of the drive, remove keeper plate from the alignment pin. (Pulling keeper plate up and toward the front of the drive will aid in its removal.) See Figure 4-2-8-E.

#### NOTE

Before proceeding to Step 20, the following items should be on hand:

1. Small plastic bag containing air nozzle cap. (Both will be used.)
2. HDA dust cap.

In the event the above items are not available, a clean, suitable (lint-free) material must be substituted to plug the HDA air nozzle and hose. DO NOT use the plastic caps from a replacement/spare HDA.

20. Loosen (DO NOT REMOVE) air hose clamp at the HDA end (see Figure 4-2-8-E). Slip air hose off the HDA and cap HDA air nozzle with the air nozzle cap. Immediately place small plastic bag over the air hose.

#### NOTE

Capping the HDA air nozzle and air hose will prevent dirt and dust from entering the HDA.

21. Disconnect the ground straps, HDA ribbon cable and its ground strap, and the EMA ground straps.
22. Carefully move HDA back approximately one inch. **ONLY ONE INCH!**
23. Pivot motor (fully) toward rear of drive.
24. Visually check to see if the carriage retainer has dropped into place. (See Figure 4-2-8-F.)

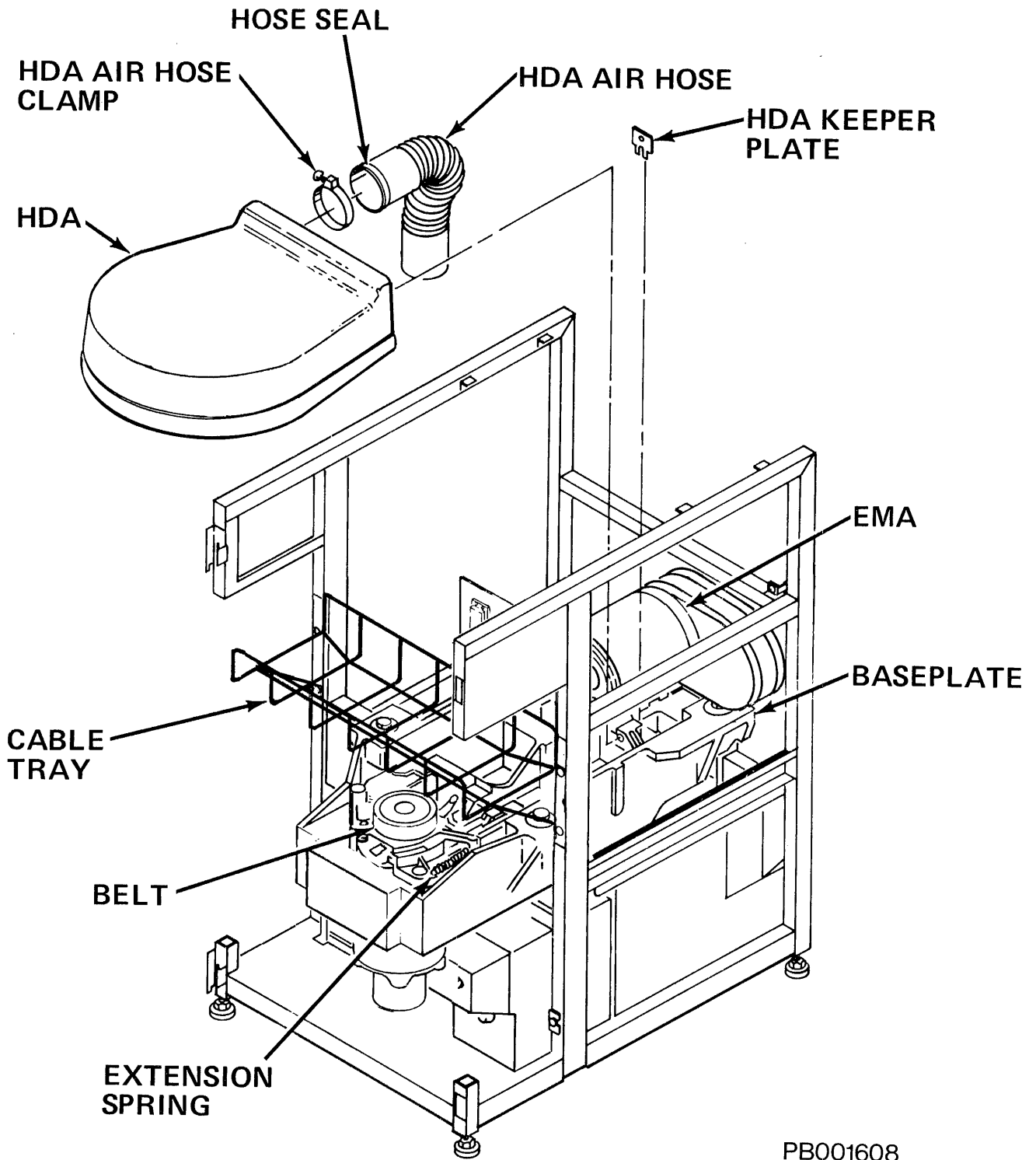

PB001608  
REV A

Figure 4-2-8-E HDA Removal

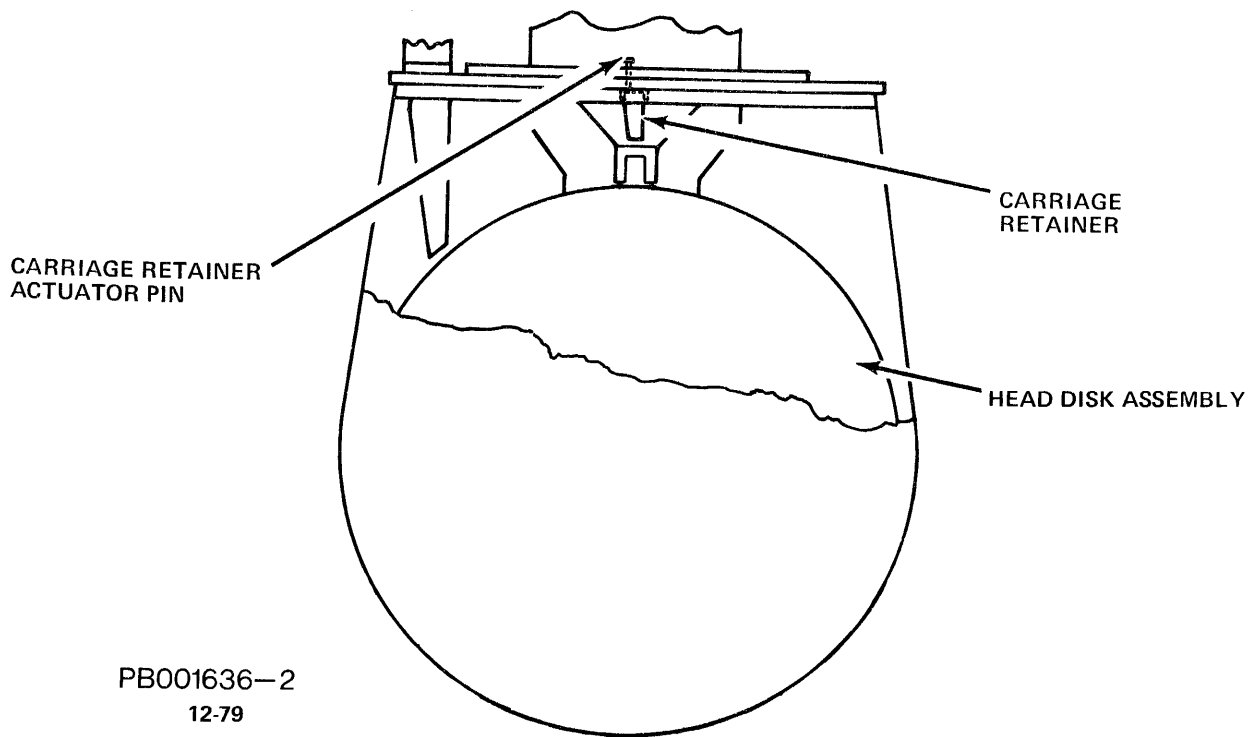

Figure 4-2-8-F HDA (Carriage Retainer)

**NOTE**

If carriage retainer has not dropped into place, release it by applying pressure (with your finger) to the carriage retainer actuator pin (reference Figure 4-2-8-F).

25. Remove the shipping rod from storage clips on the baseplate.
26. At the front of the drive, remove three (3) hex cap screws and washers that secure the EMA magnet to the baseplate. (See Figure 4-2-8-G.)

**NOTE**

1. DO NOT place the EMA magnet near magnetic tapes, HDA or disk packs when performing the remaining steps.
2. The EMA Magnet Assembly is heavy. After removal from the drive, place EMA Magnet Assembly on a solid surface (floor) to support its weight.

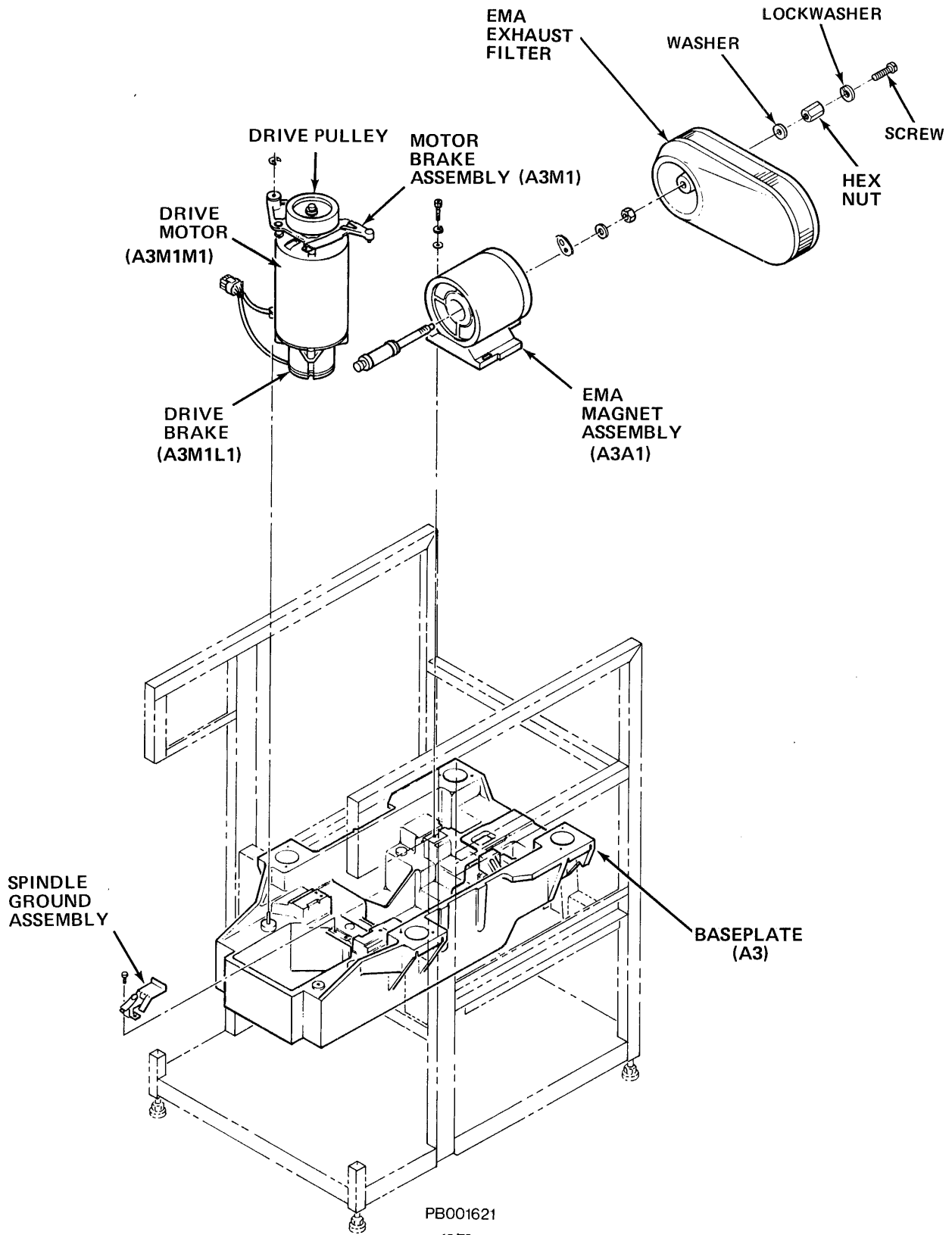

Figure 4-2-8-G EMA Magnet Assembly

### CAUTION

DO NOT bump the coil when removing the EMA from the baseplate, or damage to the coil may result.

27. Keeping pressure to the left, slide the EMA magnet back towards you (as far as it will go), along its guide pins. Carefully lift the EMA magnet straight up, then back and out of the baseplate.
28. Leaving battery connected to the leads, observe orientation of the EMA leads to the terminals at the HDA, then remove EMA leads from the HDA. (DO NOT disconnect battery from leads.)
29. At the front of the drive, carefully install the HDA red molded coil dust cap onto the HDA faceplate. Avoid any contact with or rotation of the coil while guiding cap retaining screws into position. Verify that the carriage retainer actuator pin goes into the hole in the dust cap before screwing onto the HDA. (See Figure 4-2-8-C.)
30. With both hands under the cable tray, at diagonally opposite corners, grasp HDA and ribbon cable, lift them up and back them out of the drive.
31. Place HDA in the foam pad.
32. Attach the spindle brake to the removed HDA per previous Spindle Brake Removal procedure.
33. Install one EMA gasket on EMA Magnet Assembly (over the old gasket, to create a double-thickness gasket). DO NOT REMOVE OLD GASKET. Disregard other gasket supplied. (See Figure 4-3-8-G.)

### CAUTION

Before removing the Absolute Filter (to replace it), have the new filter beside the drive, ready for immediate installation.

34. Remove the old Absolute Filter (with the old air hose and clamp intact) as follows:
  - a. Unbuckle the retaining straps on Absolute Filter.
  - b. Remove the air pressure switch hose.
  - c. Lift the filter out of the drive.
  - d. Discard old Absolute Filter and air hose.
  - e. Remove prefilter, replace if necessary.
35. Install the new Absolute Filter as follows:
  - a. Vacuum clean the blower assembly to remove any accumulated dust.

- b. Place the new Absolute Filter in the blower housing, centering it so that the intake opening is aligned with the blower outlet on the drive.
- c. IMMEDIATELY install the air pressure switch hose on the new filter.
- d. Fasten the replacement filter in place with the two retaining straps.
- e. Verify that the discharge port of filter remains capped.

**NOTE**

The air hose must be installed on the HDA air nozzle **before** HDA installation.

36. Remove the tape from plastic bag (containing air hose) at the HDA end of air hose. This end will not have an airflow arrow on the hose. Install the orange seal on the outer edge of hose.

**NOTE**

DO NOT remove plastic bag completely. Filter end of hose must be kept rubber-banded to ensure cleanliness.

37. Remove the air nozzle cap from HDA air nozzle and IMMEDIATELY install the hose onto the air nozzle. Check to ensure that orange seal is properly seated. Adjust if necessary. (See Figure 4-2-8-H.)
38. Use one of the pre-bent clamps to secure the seal and air hose onto the nozzle. Center the strap part on the seal. Make sure that the clamp part is on the right, flat side of nozzle.
39. Pull the smaller bent portion of the strap up through the slot in the clamp. Then bend it back down (so short portion is down flat against the clamp with no kinks or bends).
40. Hold the L-shaped bracket with the vise grips while tightening the screw to  $30 \pm 5$  in/lb with the torquing tool. ("John Ichi Torque Wrench", Model 00655Q 5/16" socket, 1" long and 1/4" drive.)

**CAUTION**

Excessive torquing will cause clamp to kink or bend which will destroy the seal.

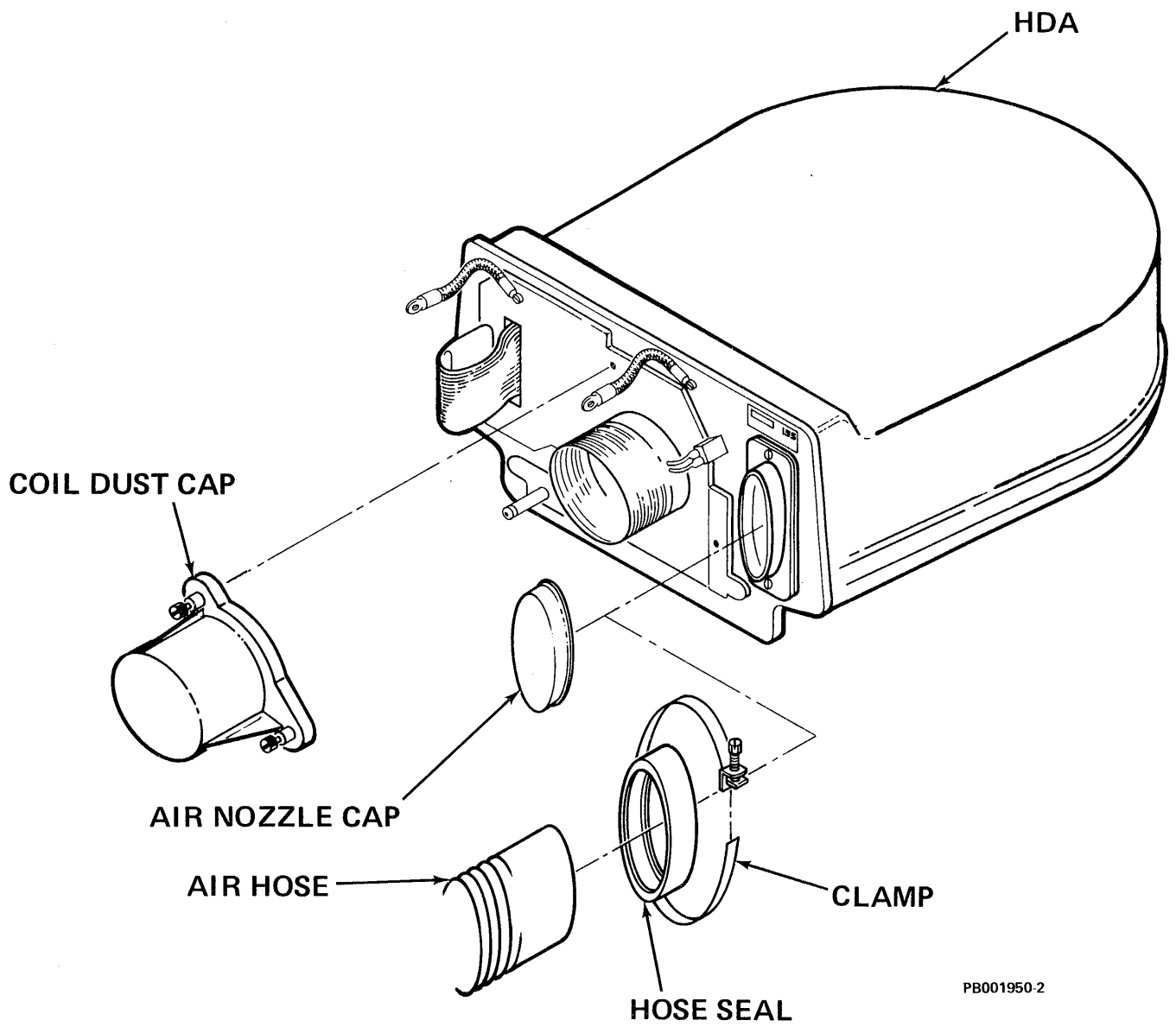

PB001950-2

Figure 4-2-8-H Air Hose Installation



### NOTE

Verify that new air hose is still covered at the Absolute Filter end.

### HDA Replacement:

### CAUTION

Perform the following HDA replacement procedure step-by-step. DO NOT DEVIATE! This procedure has been written to insure HDA replacement without HDA damage.

Use extreme care when performing the HDA replacement procedure. Handle the HDA with as little movement as possible. Avoid tipping, turning over, dropping or carelessly handling the HDA. Damage to the HDA, heads, or stack may result from mishandling.

41. Dress drive belt against drive motor pulley.
  - a. Visually check drive belt and spindle ground button for wear at this time. Replace as needed.
  - b. Insure that belt markings are on the outside of the belt before proceeding.
42. Verify drive motor is back against backplate.
43. At the rear of the drive, place HDA (with air hose connected) over the baseplate. Use extreme caution not to bump or jar the HDA when doing this. Slide HDA forward and lower it into place behind drive motor pulley.

### NOTE

Bottom of the HDA has two mounting feet that slide between the black plastic guides on the baseplate. HDA faceplate has an alignment pin which goes into the alignment block.

44. Seat mounting feet on the supporting surfaces between the black plastic guides and guide HDA into position until the alignment pin engages the alignment block.

**NOTE**

Verify that drive belt encircles the motor pulley and spindle pulley.

**CAUTION**

DO NOT touch or bump the coil while performing Step 44. Damage to the coil may result.

45. Carefully adjust the air hose and insure it is sealed.
46. Install EMA leads (with VOM/battery attached) at the rear of the HDA in the same physical orientation as they were removed.
47. Place HDA ribbon cable on top of the HDA (away from coil). Slide HDA forward until its faceplate is approximately one inch (1") from the alignment block.

**CAUTION**

DO NOT bump the coil while performing Step 48. Damage to the coil may result.

48. At the front of the drive, place EMA magnet on baseplate lifting the EMA 1/2-inch to clear front alignment pins. Slide the EMA magnet forward until it is firmly (seated against the rearmost guide pins) on the left guide pin. Install and tighten the three (3) EMA screws and washers that secure the EMA to the baseplate.

**NOTE**

Verify that the crash stop is still in the "HDA REMOVAL" position and remains there through Step 62.

**NOTE**

1. As the EMA approaches the HDA, observe carriage for movement (or continues to be held) towards the spindle. (The magnetic field repels the battery-induced field in the coil.)

If this condition does not occur, recheck polarity of the VOM/battery.

**NOTE (Contd)**

2. The EMA magnet must be firmly seated against the rearmost guide pin when performing Step 48. If the magnet is not in correct position, the drive may not be able to access the innermost cylinders.

49. Slowly move HDA the remaining inch toward the EMA.

**NOTE**

When EMA engages the carriage retainer pin, the retainer will rise.

50. Install HDA keeper plate on the alignment pin. (Be sure the lower edge of the HDA keeper plate is sitting on the step of the alignment block.)

**NOTE**

The HDA keeper plate will be loose until the extension spring is installed in Step 52.

51. Center drive belt on motor pulley and spindle pulley.

**NOTE**

Insure that belt markings are on the outside of belt before proceeding.

52. Install drive belt extension spring, using a looped tie wrap or cord. Pull spring to rear stud. Install belt guard.

**NOTE**

Drive belt extension spring must be seated into the grooves of the front and rear studs.

53. Reconnect the ground straps and HDA ribbon cable.

**NOTE**

1. Verify that CB2 and Service Switch are OFF before proceeding.
2. Place fiber washer against backplane. This prevents the ground strap shorting backpanel etches.

54. Remove the rubber band and plastic bag from Absolute Filter end of air hose and install the black seal. This seal is split and fits over the end of the air hose.

55. Remove cap at discharge port of Absolute Filter. Attach the hose, using a circular back and forth motion to the discharge port of the Absolute Filter. Check to ensure that seal is properly seated. Adjust if necessary. (See Figure 4-2-8-J.)

**NOTE**

Verify that there is clearance between air hose and EMA Filter, air ducts and baseplate. Also verify that air hose does not rub foam padding inside the front door of drive.

56. Use the second, pre-bent clamp to secure the seal and air hose onto the discharge port.
57. Center the strap on the seal. Pull the smaller bent portion of the strap through the slot in the clamp. Then bend it back (so short portion is flat against the clamp with no kinks or bends).
58. Hold the L-shaped bracket with the vise grips while tightening the screw to  $30 \pm 5$  in/lb with torquing tool "John Ichi Torque Wrench", Model 00655Q 5/16" socket, 1" long, 1/4" drive.

**CAUTION**

Excessive torquing will cause clamp to kink or bend which will destroy the seal.

59. No air hose purging is required. All factory sealed air hoses are contaminant-free.

**NOTE**

The lockwasher and screw will be removed only when using the shipping rod.

60. Set CB1, CB3 and SERVICE switch ON in that order.

**CAUTION**

To avoid damage to HDA, stack, or heads, read Step 61 completely before proceeding. Verify CB2 is OFF.

61. Place the FE LOCAL/NORMAL switch to LOCAL.
62. Enter 'FE' into the FE panel keyboard. Depress ENTER/STEP switch.

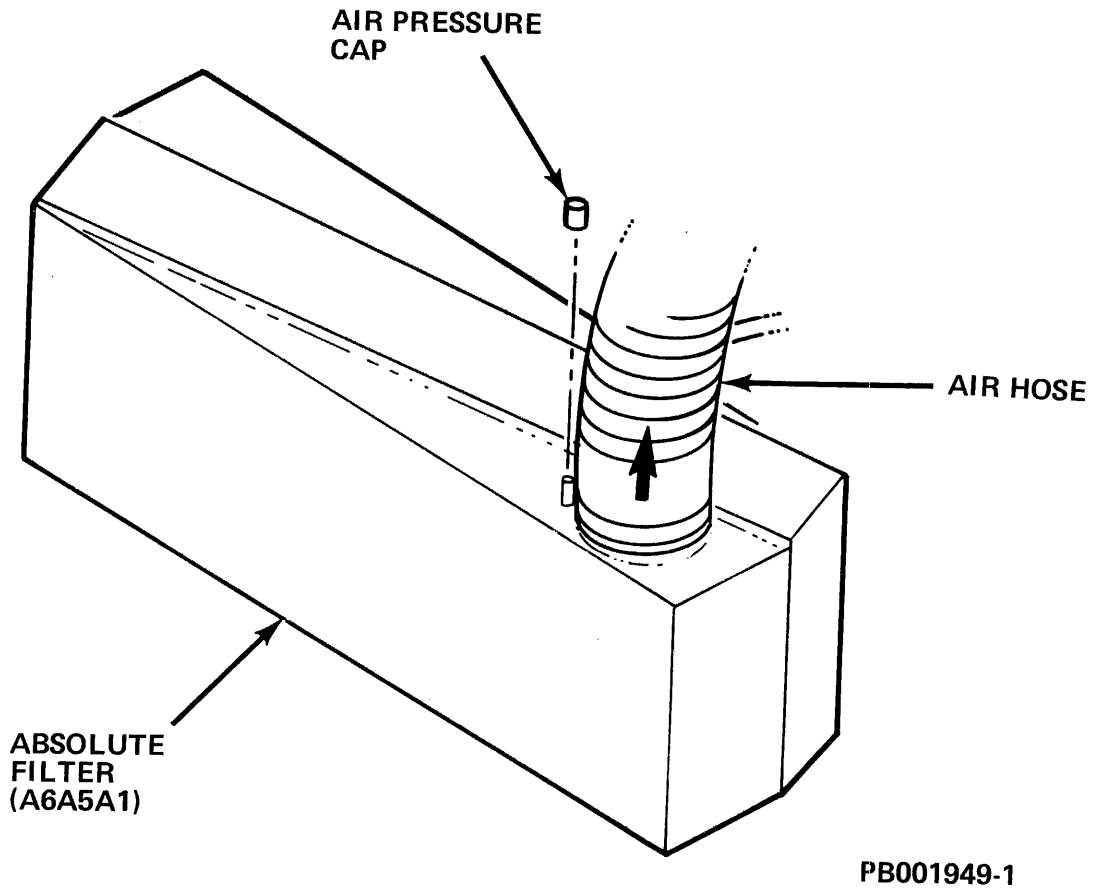

Figure 4-2-8-J Air Hose Connection

63. Enter '3E' into the FE panel keyboard.
64. Depress ENTER/STEP switch.
65. Enter 'FF'.
66. Depress ENTER/STEP switch.
67. When stack comes up to speed, reverse the leads to the VOM/battery and visually observe that the carriage is in its fully retracted position (towards EMA).
68. With the carriage in its fully retracted position, turn the crash stop indicator arm to "OPERATE" position. Tighten crash stop nut.
69. Replace EMA dust cap on the back of EMA using the following procedure: The new attaching hardware is supplied (washer, lockwasher, hex nut and screw).
  - a. Put new EMA Exhaust Filter in place. (Position it as shown in Figure 4-2-8-K.)
  - b. Place the hex nut and washer on the crash stop rod and tighten.
  - c. Thread the lockwasher and screw into the hex nut and tighten.

**NOTE**

The lockwasher will be removed only when using the shipping rod.

70. Replace shipping rod into holder on front of baseplate.

**NOTE**

Carriage should be in a fully retracted position.

71. Reverse E1 and E2 EMA leads at VOM/battery and visually confirm the carriage travels in a smooth, even motion toward the spindle.
72. Remove the VOM/battery and visually confirm that the carriage travels back toward EMA with a smooth even motion.
73. Reverse VOM/battery leads, placing them across E1, E2 EMA leads. Visually confirm that carriage fully retracts to the fully retracted position.
74. Depress RESET switch.
75. Enter '3F'.
76. Depress ENTER/STEP switch.
77. Enter 'FF'.
78. Depress ENTER/STEP switch.
79. When the stack stops spinning set the FE LOCAL/NORMAL switch to NORMAL. Set the SERVICE switch, CB3, and CB1 OFF in that order.

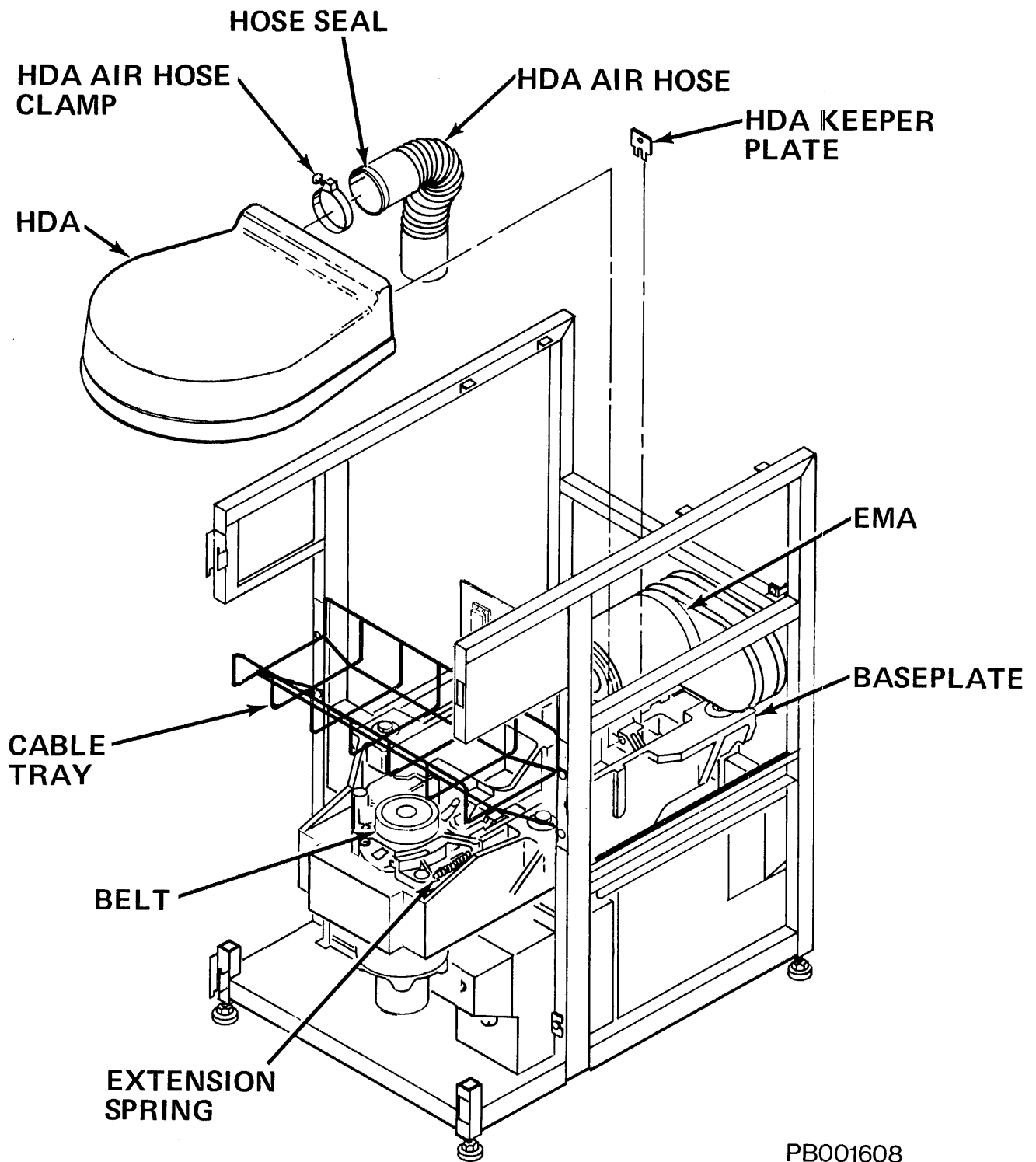

PB001608  
REV A

Figure 4-2-8-K EMA Filter Installation

80. Disconnect VOM battery and connect E1, E2 EMA leads to the backpanel as marked (i.e. E1 to E1; E2 to E2).
81. At the front of the drive, replace the shield cover assembly.
82. Set CB1, CB2, CB3 and SERVICE switch ON in that order. Set MASSBUS ENABLE/DISABLE switch to ENABLE.
83. Replace the electronics library cover, and tighten two screws in keyhole slots. Close drive top, front, and rear covers.
84. Place START/STOP switch to the START position.
85. Run the RP07 formatter software, perform subsystem verification, then resume customer operations.
86. Place an "X" through number "062" on the Unit FCO Label. This is for tracking purposes only. Disregard the "Exception Notice" which is sent on all spare HDAs.

HDA Removal for Partial Kit ONLY:

87. Remove the clamp at the Absolute Filter end of air hose. Remove the air hose from the Absolute Filter. Immediately cover the air hose and the discharge port with caps or plastic bag.
88. At the rear of the drive, remove belt guard and belt extension spring. (A looped tie wrap or cord can be used to pull belt extension spring off the back stud.) See Figure 4-2-8-E.
89. At the front of the drive, remove keeper plate from the alignment pin. (Pulling keeper plate up and toward the front of the drive will aid in its removal.) See Figure 4-2-8-E.
90. Disconnect the ground straps, HDA ribbon cable and its ground strap, and the EMA ground strap.
91. Carefully move HDA back approximately one inch.
92. Pivot motor (fully) toward rear of drive.
93. Visually check to see if the carriage retainer has dropped into place. (See Figure 4-2-8-F.)

**NOTE**

If carriage retainer has not dropped into place, release it by applying pressure (with your finger) to the carriage retainer actuator pin. (See Figure 4-2-8-F.)

94. Remove the shipping rod from storage clips on the baseplate.



95. At the front of the drive, remove three (3) hex cap screws and washers that secure the EMA magnet to the baseplate. (See Figure 4-2-8-G.)

**NOTE**

1. DO NOT place the EMA magnet near magnetic tapes, HDA or disk packs when performing the remaining steps.
2. The EMA Magnet Assembly is heavy. After removal from the drive, place EMA Magnet Assembly on a solid surface (floor) to support its weight.

**CAUTION**

DO NOT bump the coil when removing the EMA from the baseplate. Damage to the coil may result.

96. Keeping pressure to the left, slide the EMA magnet back towards you (as far as it will go), along its guide pins. Carefully lift the EMA magnet straight up, then back and out of the baseplate.
97. Leaving battery connected to the leads, observe orientation of the EMA leads to the terminals at the HDA, then remove EMA leads from the HDA. (DO NOT disconnect battery from leads.)
98. With both hands under the cable tray, at diagonally opposite corners, grasp HDA (with air hose attached) and ribbon cable. Lift them up and back, then out of the drive.
99. Place HDA in the foam pad.
100. Attach the spindle brake to the removed HDA per previous Spindle Brake Removal procedure.
101. Remove the old gaskets on EMA Magnet Assembly and install the two new gaskets (one on the other, to create a double-thickness gasket). (See Figure 4-2-8-G.)
102. Install the old air hose with seals onto the new HDA as follows: (See Figure 4-2-8-H.)
  - a. Remove the air nozzle cap from the new HDA air nozzle.
  - b. Remove the clamp and hose from the old HDA and immediately install the hose onto the new HDA nozzle. Check to ensure that orange seal is properly seated. Adjust if necessary.

- c. Use one of the new pre-bent clamps to secure the seal and air hose onto the nozzle. **Do not reuse old clamp.** Center the strap on the seal. Ensure that clamp part is on the right, flat side of nozzle.
- d. Pull the smaller bent portion of the strap up through the slot in the clamp. Then bend it back down (so short portion is down flat against the clamp with no kinks or bends).
- e. Hold the L-shaped bracket with the vise grips while tightening the screw to  $30 \pm 5$  in/lb with the torquing tool.

**CAUTION**

Excessive torquing will cause clamp to kink or bend which will destroy the seal.

- f. Verify that air hose is still capped or covered at filter end.

HDA Replacement:

**CAUTION**

1. Perform the following HDA replacement procedure step-by-step. **DO NOT DEVIATE!** This procedure has been written to insure HDA replacement without HDA damage.
2. Use extreme care when performing the HDA replacement procedure. Handle the HDA with as little movement as possible. Avoid tipping, turning over, dropping or carelessly handing the HDA. Damage to the HDA, heads, or stack may result from mishandling.

- 103. Dress drive belt against drive motor pulley.
  - a. Visually check drive belt and spindle ground button for wear at this time. Replace as needed.
  - b. Insure that belt markings are on the outside of the belt before proceeding.
- 104. Verify drive motor is back against backplate.
- 105. At the rear of the drive, place HDA (with air hose connected) over the baseplate. Use extreme caution not to bump or jar the HDA when doing this. Slide HDA forward and lower it into place behind drive motor pulley.

**NOTE**

Bottom of the HDA has two mounting feet that slide between the black plastic guides on the baseplate. HDA faceplate has an alignment pin which goes into the alignment block.

106. Seat mounting feet on the supporting surfaces between the black plastic guides and guide HDA into position until the alignment pin engages the alignment block.

**NOTE**

Verify that drive belt encircles the motor pulley and spindle pulley.

**CAUTION**

DO NOT touch or bump the coil while performing Step 106. Damage to the coil may result.

107. Carefully adjust the air hose and insure it is sealed.
108. Install EMA leads (with VOM/battery attached) at the rear of the HDA in the same physical orientation as they were removed.
109. Place HDA ribbon cable on top of the HDA (away from coil). Slide HDA forward until its faceplate is approximately one inch (1") from the alignment block.

**CAUTION**

DO NOT bump the coil while performing Step 110. Damage to the coil may result.

110. At the front of the drive, place EMA magnet on baseplate lifting the EMA 1/2-inch to clear front alignment pins. Slide the EMA magnet forward until it is firmly (seated against the rearmost guide pins) on the left guide pin. Install and tighten the three (3) EMA screws and washers that secure the EMA to the baseplate.

**NOTE**

Verify that the crash stop is still in the "HDA REMOVAL" position and remains there through Step 123.

**NOTE**

1. As the EMA approaches the HDA, observe carriage for movement (or continues to be held) towards the spindle. (The magnetic field repels the battery-induced field in the coil.)

If this condition does not occur, recheck polarity of the VOM/battery.

2. The EMA magnet must be firmly seated against the rearmost guide pin when performing Step 110. If the magnet is not in correct position, the drive may not be able to access the innermost cylinders.

111. Slowly move HDA the remaining inch toward the EMA.

**NOTE**

When EMA engages the carriage retainer pin, the retainer will rise.

112. Install HDA keeper plate on the alignment pin. (Be sure the lower edge of the HDA keeper plate is sitting on the step of the alignment block.)

**NOTE**

The HDA keeper plate will be loose until the extension spring is installed in Step 114.

113. Center drive belt on motor pulley and spindle pulley.

**NOTE**

Insure that belt markings are on the outside of belt before proceeding.

114. Install drive belt extension spring, using a looped tie wrap or cord. Pull spring to rear stud. Install belt guard.

**NOTE**

Drive belt extension spring must be seated into the grooves of the front and rear studs.

115. Reconnect the ground straps and HDA ribbon cable.

#### NOTE

1. Verify that CB2 and Service Switch are OFF before proceeding.
  2. Place fiber washer against backplane. This prevents the ground strap shorting backpanel etches.
116. Remove the caps or plastic bags from the filter end of air hose and from the discharge port of Absolute Filter.
117. Immediately attach the hose, using a circular back and forth motion to the discharge port. Check to ensure that black seal is properly seated. Adjust if necessary. (See Figure 4-2-8-J.)

#### NOTE

- Verify that there is clearance between air hose and EMA filter, air ducts and baseplate. Also verify that air hose does not rub foam padding inside the front door of the drive.
118. Use the second pre-bent clamp to secure the seal and air hose onto the discharge port. **Do not re-use old clamp.** Center the strap part on the seal. Pull the smaller bent portion of the strap through the slot in the clamp. Then bend it back (so short portion is flat against the clamp with no kinks or bends).
119. Hold the L-shaped bracket with the vise grips while tightening the screw to 30 + 5 in/lb with torquing tool "John Ichi Torque Wrench", Model 00655Q 5/16" socket, 1" long, 1/4" drive.

#### CAUTION

Excessive torquing will cause clamp to kink or bend which will destroy the seal.

120. Set CB1, CB3 and SERVICE switch ON in that order.

#### CAUTION

To avoid damage to HDA, stack, or heads, read Step 122 completely before proceeding. Verify CB2 is OFF.

121. Place the FE LOCAL/NORMAL switch to LOCAL.
122. Enter 'FE' into the FE panel keyboard. Depress ENTER/STEP switch.

123. Enter '3E' into the FE panel keyboard.
124. Depress ENTER/STEP switch.
125. Enter 'FF'.
126. Depress ENTER/STEP switch.
127. When stack comes up to speed, reverse the leads to the VOM/battery and visually observe that the carriage is in its fully retracted position (towards EMA).
128. With the carriage in its fully retracted position, turn the crash stop indicator arm to "OPERATE" position. Tighten crash stop nut.
129. Install the new EMA filter using the existing mounting hardware per the following procedure.
  - a. Put new filter in place. (Position it as shown in Figure 4-2-8-K.)
  - b. Place the hex nut and washer on the crash stop rod and tighten.
  - c. Thread the lockwasher and screw into the hex nut and tighten.
  - d. Discard the old EMA filter.

**NOTE**

The lockwasher and screw will be removed only when using the shipping rod.

130. Replace shipping rod into holder on front of baseplate.

**NOTE**

Carriage should be in a fully retracted position.

131. Reverse E1 and E2 EMA leads at VOM/battery and visually confirm the carriage travels in a smooth, even motion toward the spindle.
132. Remove the VOM/battery and visually confirm that the carriage travels back toward EMA with a smooth even motion.
133. Reverse VOM/battery leads, placing them across E1, E2 EMA leads. Visually confirm that carriage fully retracts to the fully retracted position.
134. Depress RESET switch.
135. Enter '3F'.
136. Depress ENTER/STEP switch.
137. Enter 'FF'.
138. Depress ENTER/STEP switch.

139. When the stack stops spinning set the FE LOCAL/NORMAL switch to NORMAL. Set the SERVICE switch, CB3, and CB1 OFF in that order.
140. Disconnect VOM battery and connect E1, E2 EMA leads to the backpanel as marked (i.e. E1 to E1; E2 to E2).
141. At the front of the drive, replace the shield cover assembly.
142. Set CB1, CB2, CB3 and SERVICE switch ON in that order. Set MASSBUS ENABLE/DISABLE switch to ENABLE.
143. Replace the electronics library cover, and tighten two screws in keyhole slots. Close drive top, front, and rear covers.
144. Place START/STOP switch to the START position.
145. Run the RP07 formatter software, perform subsystem verification, then resume customer operations.

Packaging the defective HDA:

**NOTE**

1. Be sure all packing materials are on hand before proceeding.
  2. Be sure the HDA air nozzle cap, and the HDA dust cap are properly installed on the defective HDA.
1. Carefully slide the defective HDA into carrier bag. Seal bag closed with tape.
  2. Carefully lift the HDA and place it into the foam pad and into the container. Seal closed with tape.
  3. Label, address and properly mark large container with factory address and contents.
  4. Return container to factory.

**4.2.9 Operator Control Panel Assembly/FE Panel Assembly (A1A20) (P/N 9035511-00)**

The Operator Control Panel Assembly (see Figure 4-2-9) contains the FE Panel Assembly which is removed and replaced as one unit. Hereafter, the Operator Control Panel Assembly/FE Panel Assembly will be referred to as the "Control Panel Assembly".

This procedure required the following tools:

- Screwdriver

To remove the Control Panel Assembly:

1. Obtain permission to disrupt customer operations. Place drive ONLINE/OFFLINE switch to OFFLINE.

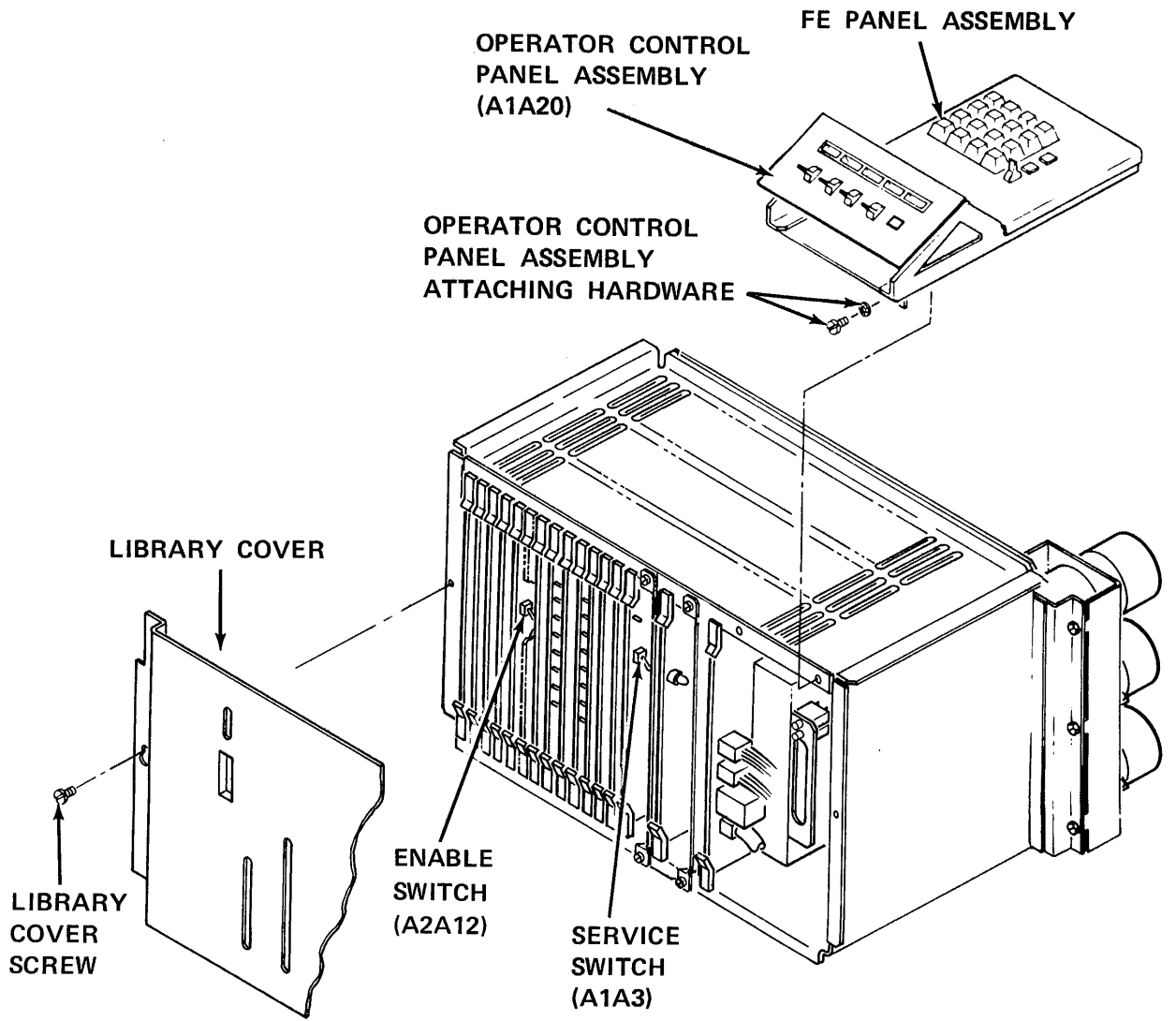

PB001626-1  
12/79

Figure 4-2-9 Operator Control Panel Assembly/FE Panel Assembly



2. Place START/STOP switch in the STOP position.
3. Open drive top cover to its detent position.
4. Open drive front door.
5. Loosen (DO NOT REMOVE) two screws located in the keyhole slots that secure the electronics library cover to the library cage. Lift the cover up and away from the drive.
6. Set MASSBUS ENABLE/DISABLE switch to DISABLE (down).
7. Set SERVICE Switch (A1A3) OFF.
8. Open drive rear door.
9. Set CB3 OFF.

**CAUTION**

DO NOT allow flex circuit ribbon cable to contact backpanel pins or wires during removal (Step 10) or damage to the pins and/or wires may result.

10. Remove Control Panel Assembly (ribbon cable) flex circuit plug connector from backpanel at J7, Row B, pins 41-80.

**NOTE**

Rows are denoted by letters located on the right side of the backpanel.

11. Loosen and remove two self-tapping screws and lockwashers located at the lower front end of the Control Panel Assembly.
12. Loosen and remove two self-tapping screws and lockwashers located at the back end of the Control Panel Assembly.
13. Holding ribbon cable away from the backpanel pins and wires, lift Control Panel Assembly up and off the top of the drive.

To replace the Control Panel Assembly:

**NOTE**

The Control Panel Assembly must be correctly repositioned on the library cage to allow drive top cover to close.

1. Loosen 4 screws securing 2 brackets to bottom of the Control Panel Assembly.

2. Holding the ribbon cable, set the Control Panel Assembly down over 4 screws.
3. Reconnect ribbon cable J07 row B pins 41-80.

**CAUTION**

Be sure to connect ribbon cable to proper pins or damage could occur.

4. Lower the top cover.

To Adjust the Control Panel Assembly for Proper Seating:

1. From the front of the drive reach under the lip of the top cover, under the control panel and adjust the control panel to insure a flush fit against the top cover control panel opening.
2. Tighten the two horizontal screws located at the lower front end of the Control Panel Assembly.
3. Tighten the two vertical screws located at the lower front of the Control Panel Assembly.
4. Open the top cover.
5. From the rear of the drive tighten the remaining four screws securing the Control Panel Assembly to the Electronics Library.

**4.2.10 EMA Magnet Assembly (A6A3A1) (P/N 9026278-05)**

Removing and replacing the EMA Magnet Assembly from an RP07 drive requires first repositioning the HDA. It is therefore recommended whenever the EMA Magnet Assembly must be removed from the drive, a replacement EMA Magnet Assembly must be on hand, ready for immediate installation. See Figure 4-1-10-A.

This procedure requires the following tools:

- A VOM/1.5 volt DC battery
- Plastic tie wrap or minimum 6" length of stout cord, tied in a loop
- Screwdriver
- Air Nozzle Cap
- Small plastic bag (to cap the air hose)
- Tape (electrical tape preferred)

**NOTE**

In the event a space Air Nozzle Cap or plastic bag is not available, a clean suitable material must be substituted (to plug the HDA air nozzle and air hose).

1. Obtain permission to disrupt customer operations. Place drive ONLINE/OFF-LINE switch to OFFLINE. Place START/STOP switch to STOP.

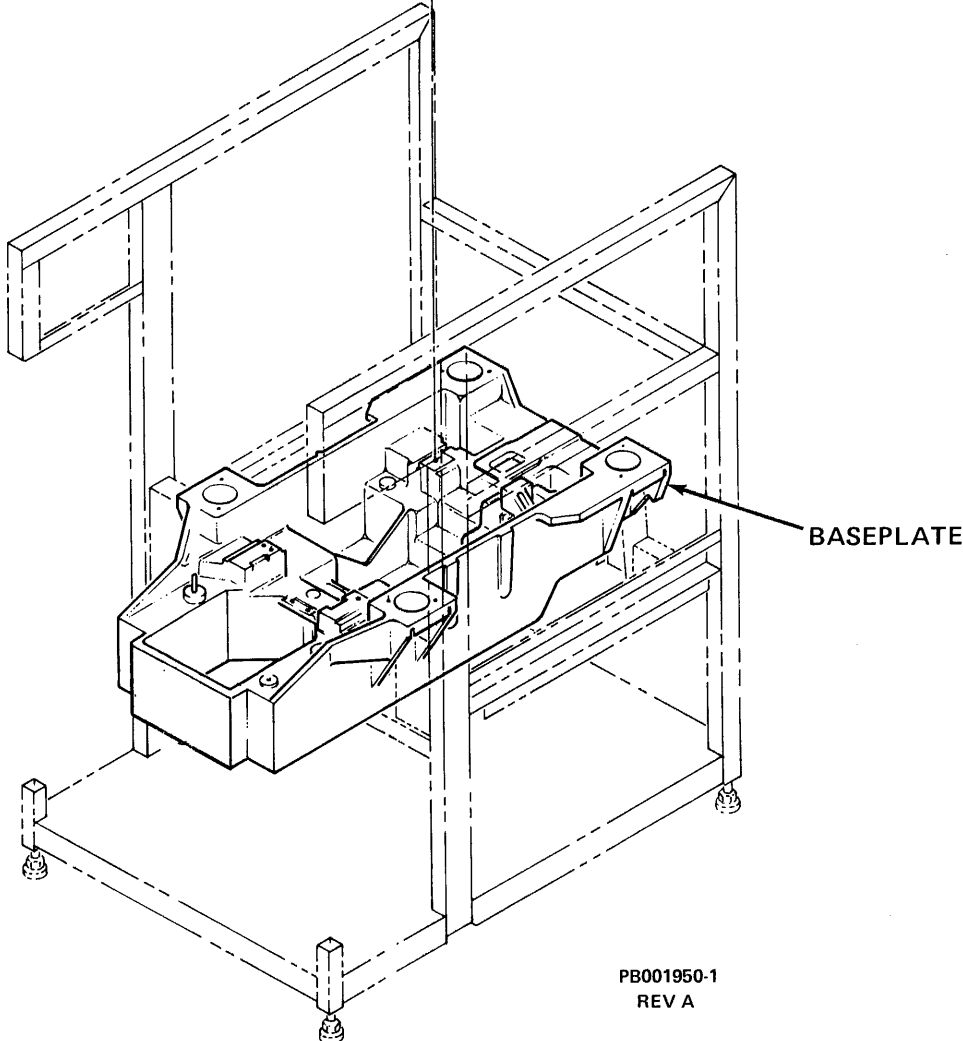
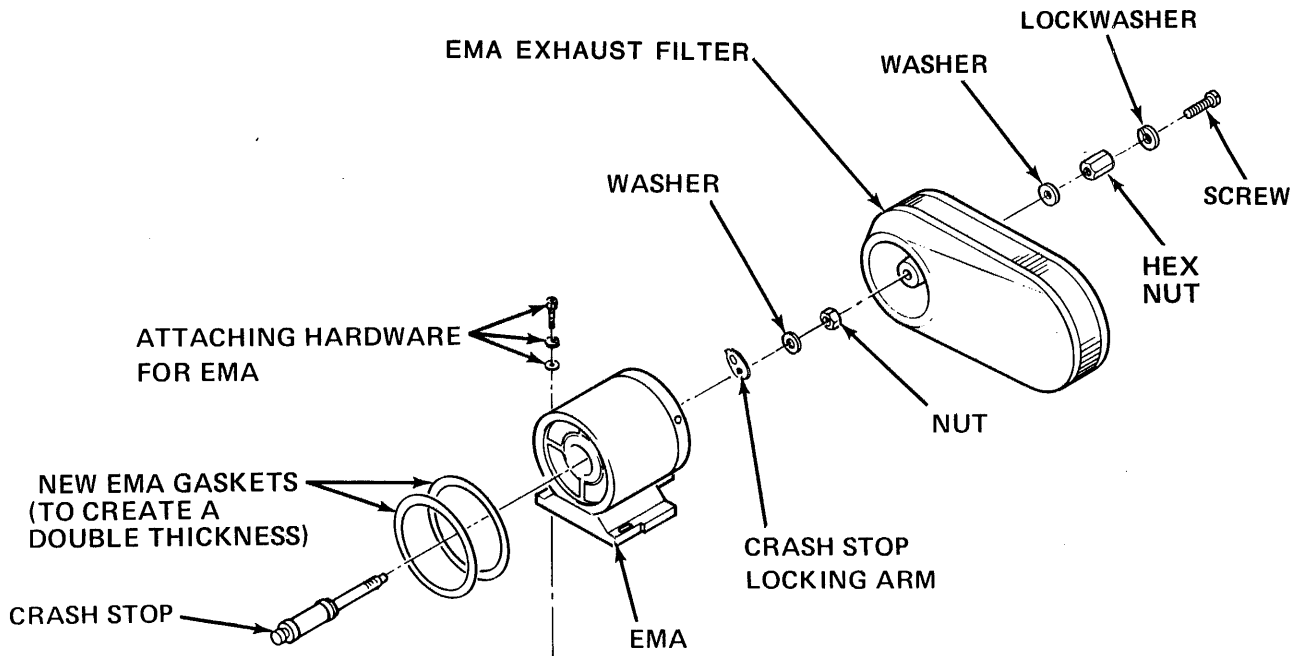

Figure 4-2-10-A EMA Magnet Assembly

2. Open drive top cover to its detent position; open drive front and rear door. Remove the electronics library cover by loosening (DO NOT REMOVE) two screws in keyhole slots. Lift library cover up and away from drive.
3. Set MASSBUS ENABLE/DISABLE switch to DISABLE.
4. Set SERVICE switch OFF.
5. Set CB3, CB2 and CB1 OFF in that order.

**NOTE**

Before disconnecting E1 and E2 EMA leads (Step 4), label and mark each lead (both ends) with its reference designations. This will insure reinstalling E1 and E2 EMA leads in the exact physical orientation as removed.

6. At the rear of the drive, disconnect EMA leads E1 and E2 from the backpanel.
7. Set CB1 and CB3 ON. Set SERVICE switch ON. Place START/STOP switch to the START position.

**CAUTION**

Placing CB1, CB3 and SERVICE Switch ON, START/STOP switch to START, allows stack to spin. This is necessary to avoid HDA damage when carriage is moved in Step 8.

**WARNING**

CB2 must remain OFF to avoid personal injury while working in the vicinity of the EMA Magnet Assembly.

8. Connect a VOM/1.5 volt DC battery across E1 and E2 EMA leads.

**NOTE**

Verify that carriage moves towards spindle. If carriage does not move toward spindle, reverse leads. Tape leads to VOM/battery.

9. At the front of the drive remove the shield cover assembly by inserting a narrow pointed object (narrow blade screwdriver) into the hole in the upper center of the shield. By applying pressure, the retainer clip will release. Pull down on the shield and slide it out.
10. At the front of the drive, remove EMA Exhaust Filter (see Figure 4-2-10-A).

11. Loosen crash stop nut and turn crash stop indicator arm to the "HDA Removal" position. (See Figure 4-2-10-B.)

**NOTE**

Turning crash stop indicator arm to the "HDA Removal" position allows the carriage to move an additional one-half inch toward the spindle.

12. With the carriage extended towards the spindle, place START/STOP switch in the STOP position.
13. When stack stops spinning, set the SERVICE switch OFF.
14. Set CB3 and CB1 OFF in that order.
15. At the rear of the drive, remove the belt guard and the belt extension spring. (A looped tie wrap or cord can be used to pull the belt extension spring off the back stud.) See Figure 4-2-10-C.
16. Remove keeper plate from the end of the alignment pin. (Pulling keeper plate up and toward the front of the drive will aid in its removal.) (See Figure 4-2-10-C.)

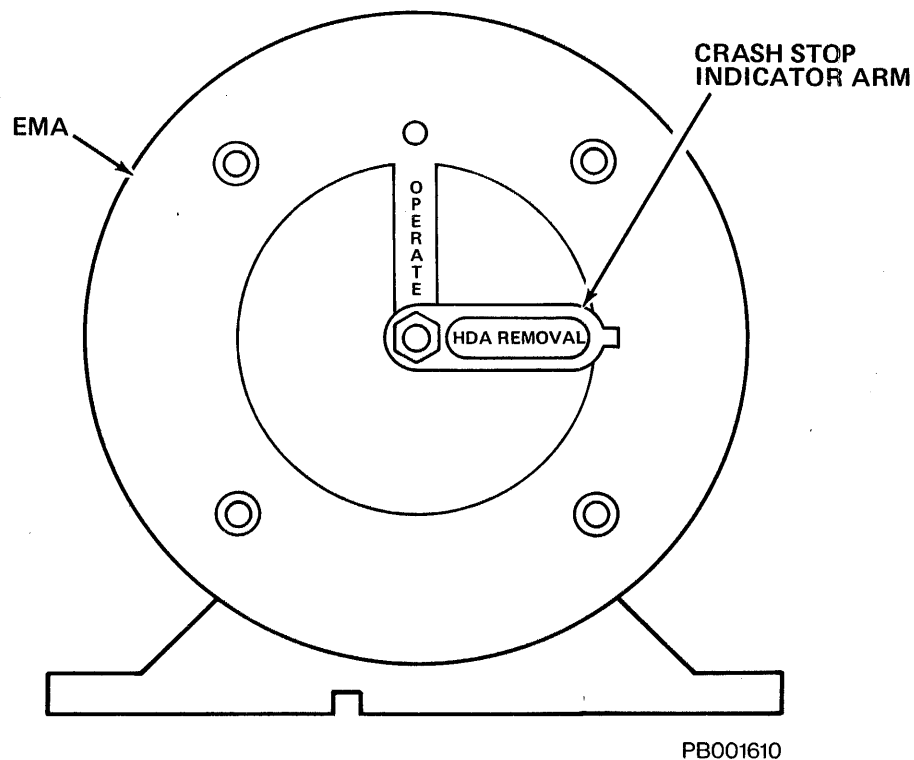
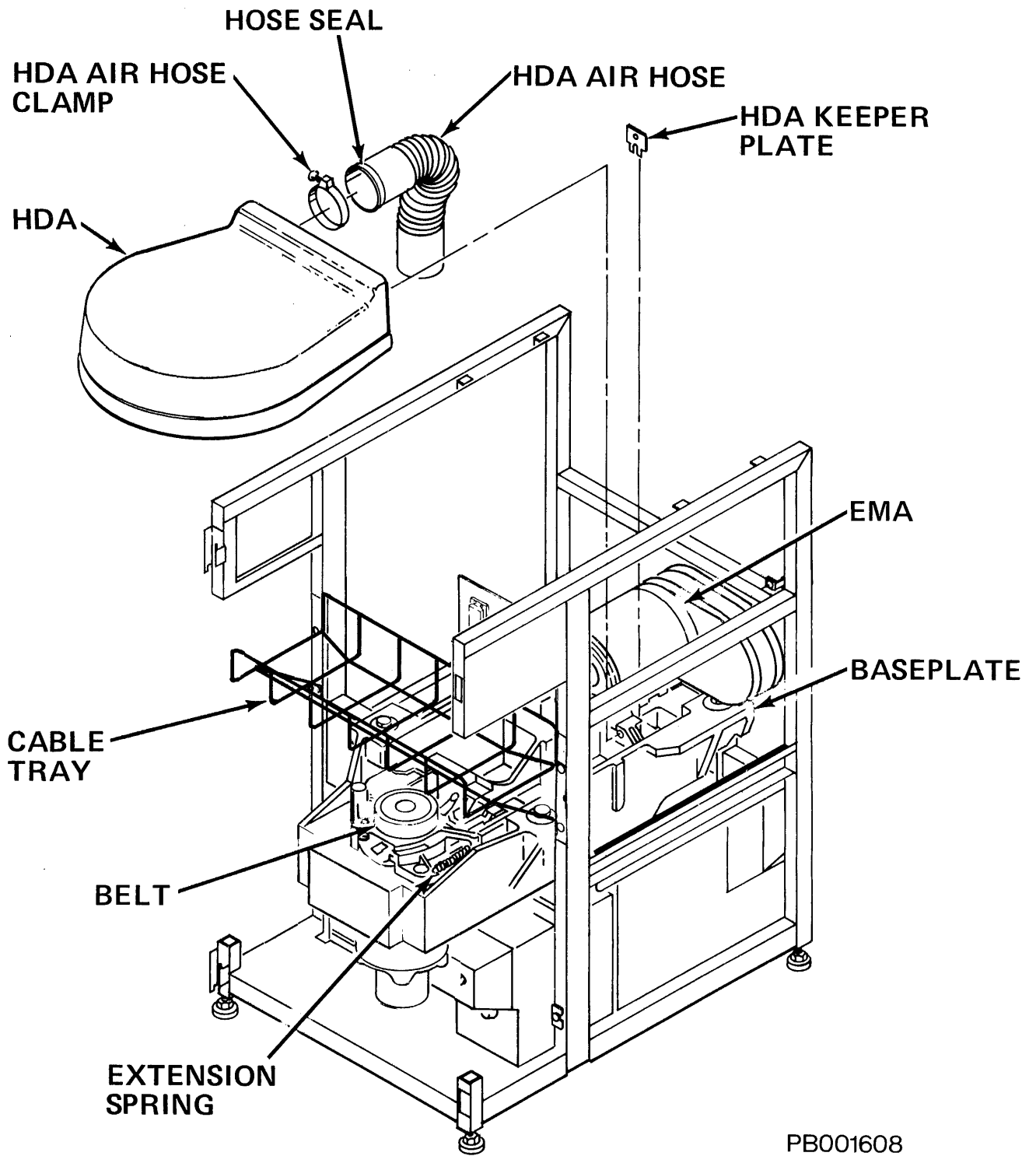

Figure 4-2-10-B EMA (Crash Stop Indicator Arm)



PB001608  
REV A

Figure 4-2-10-C HDA and Keeper Plate

**NOTE**

Before proceeding to Step 17, the following items should be on hand:

1. Small plastic bag containing air nozzle cap. (Both will be used.)
2. Air Nozzle Cap

In the event the above items are not available, a clean, suitable (lint-free) material must be substituted to plug the HDA air nozzle and air hose. DO NOT use the plastic caps from a replacement/spare HDA.

17. Loosen (DO NOT REMOVE) HDA air hose clamp (Figure 4-2-10-C). Slip air hose off the HDA and cap HDA air nozzle with the air nozzle cap. Immediately place small plastic bag over the air hose.

**NOTE**

Capping the HDA air nozzle and air hose will prevent dirt and dust from entering the HDA.

18. Disconnect the ground straps, HDA ribbon cable and its ground strap, and the EMA ground straps.
19. Carefully move HDA back approximately one inch.
20. Pivot motor (fully) toward rear of drive.
21. At the front of the drive, remove three (3) screws and washers that secure the EMA magnet to the baseplate. (See Figure 4-2-10-A.)

**NOTE**

1. DO NOT place an EMA magnet near magnetic tapes, HDAs, or disk packs when performing Step 22.
2. The EMA Magnet Assembly is heavy. After removal from the drive, place EMA Magnet Assembly on a solid surface (floor) to support its weight.

**CAUTION**

DO NOT bump the HDA coil when removing the EMA from the baseplate, or damage to the HDA coil may result.

22. Keeping pressure to the left, slide EMA back towards you (as far as it will go), along its guide pins. Carefully lift the EMA straight up, then back and out of the baseplate.

To replace the EMA Magnet Assembly:

1. At the rear of the drive, place HDA ribbon cable on top of the HDA (away from the coil).
2. At the front of the drive, place replacement EMA magnet on the baseplate. Lift the EMA magnet 1/2-inch to clear front alignment pins.

**CAUTION**

Exercise extreme care to avoid bumping and damaging the HDA coil while performing Step 3.

3. Slide the EMA magnet forward until it is firmly seated against the rearmost guide pins. Install and tighten the three (3) EMA Screws and washers that secure the EMA to the baseplate.

**NOTE**

1. Verify that the crash stop indicator arm is still in the "HDA REMOVAL" position and remains there through Step 20.
  2. As the EMA approaches the HDA, observe carriage for movement (or continues to be held) towards the spindle. (The magnetic field repels the battery-induced field in the coil.) If this condition does not occur, recheck polarity of the VOM/battery.
  3. The EMA magnet must be firmly seated against the rearmost guide pins before performing Step 5. If the magnet is not in correct position, the drive may not be able to access the innermost cylinders.
4. Slowly move HDA toward the EMA.

**NOTE**

When EMA engages the carriage retainer pin, the retainer will rise.



5. Install HDA keeper plate on the alignment pin. (Be sure the lower edge of the HDA keeper plate is sitting on the step of the alignment block.)

**NOTE**

The HDA keeper plate will be loose until the extension spring is installed in Step 7.

6. Center the drive belt on the motor pulley and spindle pulley.

**NOTE**

Insure that belt markings are on the outside of belt before proceeding.

7. Install drive belt extension spring, using a looped tie wrap or cord. Pull spring to rear stud. Install belt guard.

**NOTE**

Drive belt extension spring must be seated into the grooves of the front and rear studs.

8. Reconnect the ground straps and HDA ribbon cable.

**NOTE**

Verify that CB2 and Service Switch are OFF before proceeding.

9. Set CB1 ON (activating air system).
10. Remove the plastic bag from air hose.
11. Tap air hose and absolute filter housing to dislodge any possible contaminants.
12. Allow at least five (5) minutes purge time before proceeding to Step 13.
13. Temporarily set CB1 OFF. Remove air nozzle cap from the HDA air nozzle. Install air hose on HDA air nozzle. Tighten air hose clamp. Set CB1 ON.
14. Allow an additional five (5) minutes purge time before proceeding to Step 15.
15. Set CB3 ON. Set the SERVICE switch ON.
16. Place START/STOP switch to the START position. After the stack has come up to speed reverse the leads to the VOM/battery.
17. Visually observe that carriage is in its fully retracted position (towards EMA).
18. With the carriage in its fully retracted position, turn crash stop indicator arm to "OPERATE" position. Tighten crash stop nut.
19. Replace EMA Exhaust Filter on the back of EMA.

#### **NOTE**

Carriage should now be resting against the outer crash stop.

20. Reverse E1 and E2 EMA leads at the VOM/battery and visually confirm the carriage travels in a smooth, even motion toward the spindle.
21. Remove the VOM/battery and visually confirm that the carriage travels back toward EMA with a smooth even motion.
22. Reverse VOM/battery leads, placing them across E1 and E2 EMA leads. Visually conform that the carriage fully retracts.
23. Place START/STOP switch in the STOP position. When stack stops spinning set the SERVICE switch, CB3 and CB1 OFF in that order.
24. Disconnect the VOM/battery and connect E1 and E2 EMA leads to the backpanel.
25. Set CB1, CB2 and CB3 ON in that order. Set the SERVICE switch ON. Set the MASSBUS ENABLE/DISABLE switch to ENABLE.
26. Replace the electronics library cover, and tighten the two screws in keyhole slots.
27. Replace the shield cover assembly.
28. Place START/STOP switch in the START position.
29. Perform "Power On Start" procedure.
30. Resume customer operations.

#### **4.2.11 EMA Exhaust Filter (P/N 9049909-00)**

Opening the drive front cover and removing the shield cover assembly allows access to the EMA Exhaust Filter. The EMA Exhaust Filter is easily installed using a washer, lockwasher, hex nut, and screw per the following procedure:

#### **NOTE**

Be sure the crash stop locking arm is in the "OPERATE" position.

1. Put new filter in place. (Position it as shown in Figure 4-2-10-A.)
2. Place the hex nut and washer on the crash stop rod and tighten.
3. Thread the lockwasher and screw into the hex nut and tighten.

#### **NOTE**

The lockwasher and screw will be removed only when using the shipping rod.

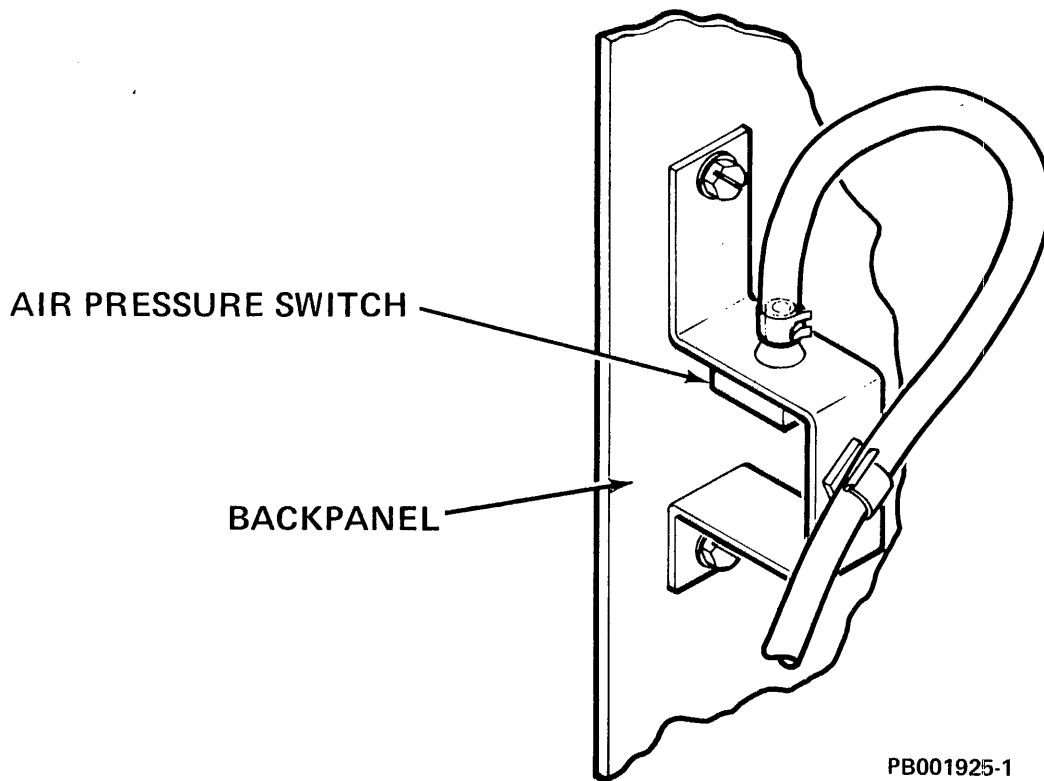

Figure 4-2-12-A Air Pressure Switch

#### 4.2.12 Air Pressure Switch (P/N 9800941-00)

The air pressure switch mounts to a bracket on the back of the electronics library backpanel. (See Figure 4-2-12-A.)

If the (clear plastic) air hose tubing, connected to the Air Pressure Switch requires replacement, see Subsection 4.2.12.1 of this manual.

This procedure requires the following tool:

- Screwdriver
1. Obtain permission to disrupt customer operations. Place drive ONLINE/OFF-LINE switch OFFLINE.
  2. Place START/STOP switch in the STOP position.
  3. Open the drive front door.
  4. Remove the electronics library cover by loosening (DO NOT REMOVE) the two screws in the keyhole slots. Lift the library cover up and away from drive.
  5. Set MASSBUS ENABLE/DISABLE switch to DISABLE (down).

6. Set the SERVICE switch to OFF.
7. At the rear of the drive, raise top cover to its detent position.
8. Open drive rear door.
9. Set CB3 OFF.
10. Disconnect the two jumper leads from the air pressure switch.

**NOTE**

DO NOT disconnect air pressure switch jumper leads from library backpanel (locations J2-79 and J280).

**CAUTION**

Use care when removing Air Pressure Switch Assembly (switch and bracket) from the library backpanel. There may be wires crossed over the bracket legs. Careless removal of this assembly may cause damage to backpanel wiring.

**NOTE**

DO NOT discard the insulator removed in Step 11. It will be reinstalled during replacement of Air Pressure Switch Assembly.

11. Remove and save two self-tapping screws that secure Air Pressure Switch Assembly (and insulator) to library backpanel.

**NOTE**

The air hose (tubing) is clamped to the air hose bracket. It is NOT necessary to remove the hose from the loop clamp when removing and replacing the air pressure switch.

12. Remove air hose from air pressure switch. Remove the two screws, lock-washers, and nuts that secure air pressure switch to bracket. Refer to Figure 4-2-12-B.
13. Loosen the retainer clamp and remove air pressure switch. Discard switch.

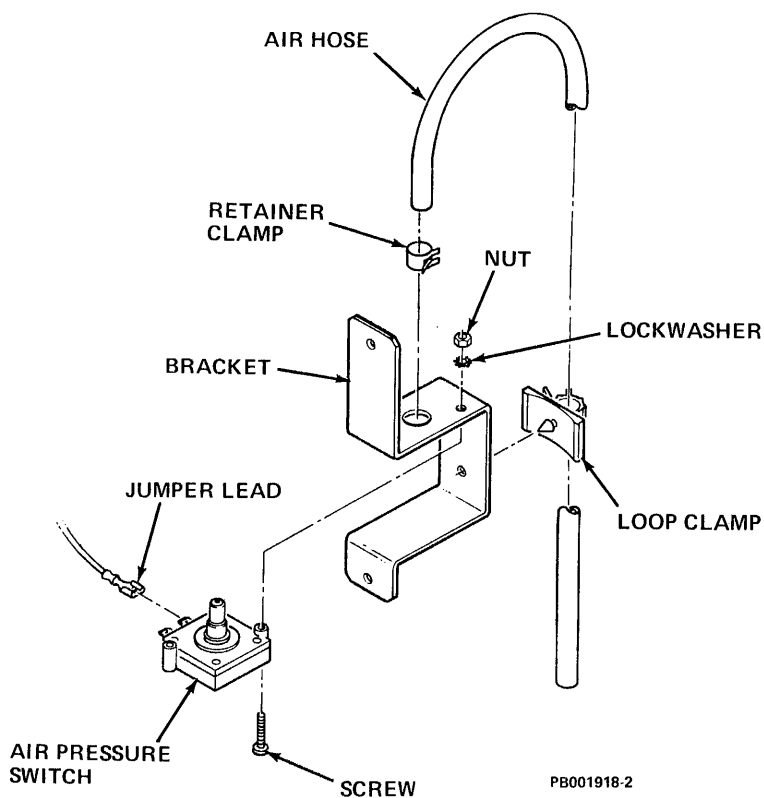

Figure 4-2-12-B Air Pressure Switch (Exploded View)

Replacing the Air Pressure Switch:

1. Install replacement air pressure switch to its mounting bracket with two screws, lockwashers, and nuts.

**NOTE**

The replacement air pressure switch must protrude through the hole in switch bracket before proceeding to Step 2.

2. Secure the switch to bracket with the retainer clamp (supplied).
3. With two self-tapping screws, install Air Pressure Switch Assembly (switch mounted to bracket) and insulator, onto the electronics library backpanel.

**NOTE**

Be sure insulator and the legs of the mounting bracket are installed under any wires that may cross mounting area.

4. Place air hose onto the switch.

5. Reconnect two jumper leads (removed in Step 6 of the removal procedure), to air pressure switch.
6. Set CB3 ON.
7. Set the SERVICE switch ON. Set the MASSBUS ENABLE/DISABLE switch to ENABLE.
8. Replace the electronics library cover.
9. Close the drive front door.
10. Close the drive top cover and rear door.
11. Perform "Power On Start" procedure.
12. Resume customer operations.

**4.2.12.1 Air Hose (Air Pressure Switch) (P/N 2551711-02)** - This procedure describes removal and replacement of the (clear plastic) air hose tubing that connects the Absolute Filter (A6A5A1) to the Air Pressure Switch.

This procedure requires the following tools:

- Screwdriver
  - Cable Ties (mounts)
1. Obtain permission to disrupt customer operations. Place drive ONLINE/OFFLINE switch to OFFLINE.
  2. Place START/STOP switch in the STOP position.
  3. Open drive front cover.
  4. At the rear of the drive, raise top cover to its detent position. Open drive rear cover.
  5. Set CB1 OFF.

**NOTE**

The replacement air hose (tubing) is approximately 130 cm (51 inches) long. Visually note that one end of air hose contains a snubber. The snubber end of the air hose must be installed onto the absolute filter air pressure tap.

6. Remove existing air hose (tubing) from air pressure switch, see Figure 4-2-12-1-B.

#### NOTE

The air pressure switch is mounted to a bracket on the electronics library backpanel.

7. Carefully pull existing air hose (tubing) down through the clamp.
8. Slide replacement air hose tubing up through the clip and install air hose tubing onto the air pressure switch.
9. To insure physical orientation of replacement air hose (tubing), route replacement air hose (tubing) next to the old air hose tubing with remainder of it on top of the absolute filter.
10. Remove cable ties that secure old air hose tubing to the transformer wires (along the side of drive frame).
11. Install cable ties around replacement air hose (tubing), securing air hose to transformer wires.
12. At the front of the drive, remove old air hose (tubing) from absolute filter tap (see Figure 4-2-12-1-A).
13. Install replacement air hose (snubber end) on the innermost tap of the absolute filter (see Figure 4-2-12-1-A).
14. Carefully remove the old air hose (tubing) from drive, discard it.
15. Close drive front cover.
16. At the rear of the drive, set CB1 ON. Close drive rear and top covers.
17. Place START/STOP switch in the START position.
18. Perform "Power On Start" procedure.
19. Resume customer operations.

**4.2.12.2 Air Hose (HDA/Absolute Filter) (P/N 9026174-00)** - The HDA-Absolute Filter air hose directs highly filtered ambient air from the Absolute Filter (A6A5A1) to the HDA (A7). It is attached to the absolute filter discharge opening, and the HDA air nozzle. (See Figure 4-2-12-2.) The following procedure describes the removal and replacement of the air hose.

This procedure requires the following tool:

- Screwdriver

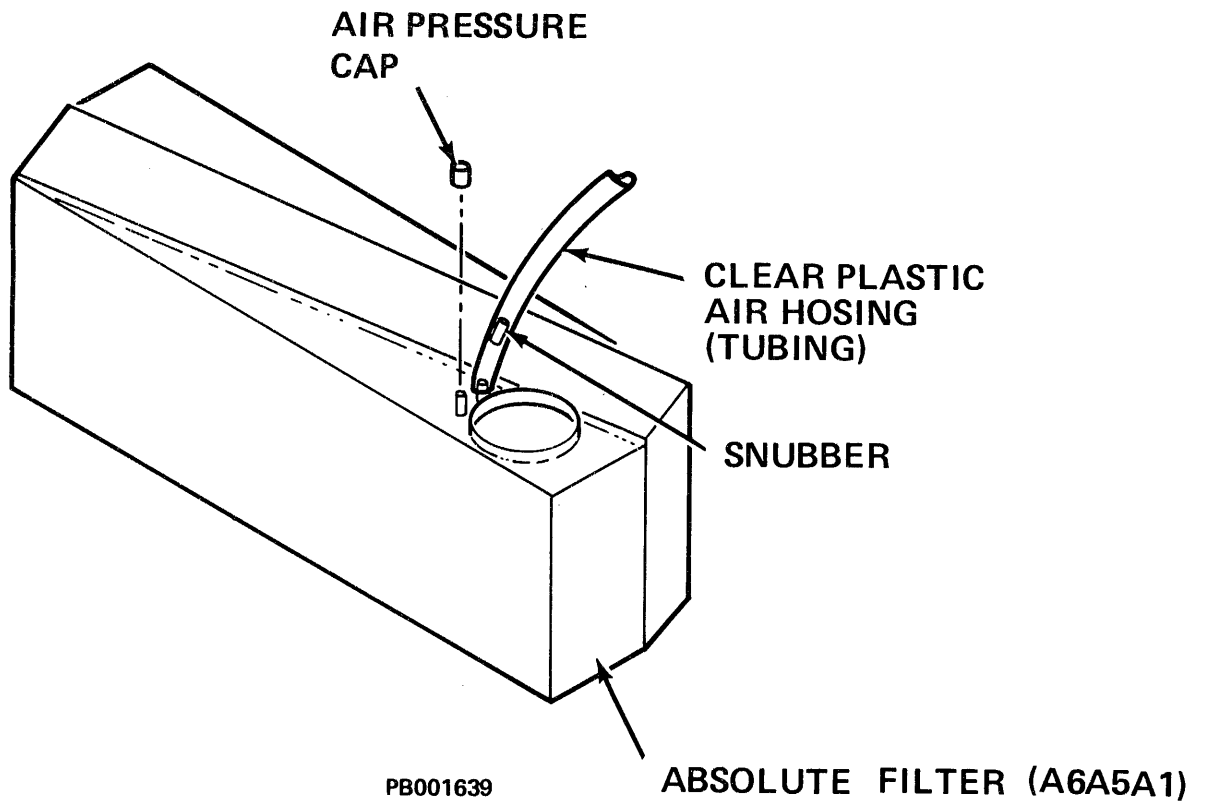

Figure 4-2-12-1-A Absolute Filter (Air Taps)

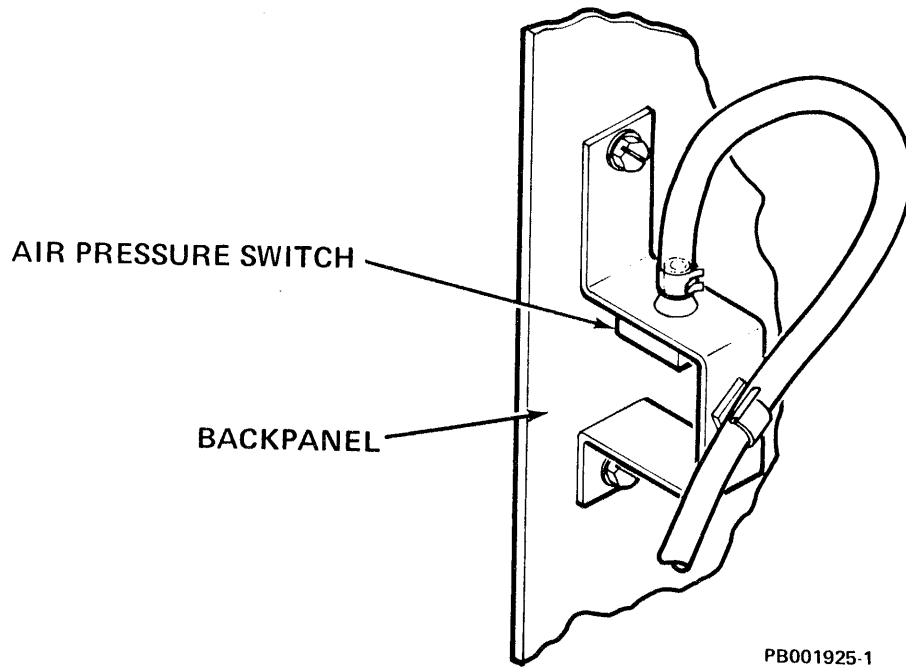

Figure 4-2-12-1-B Air Pressure Switch



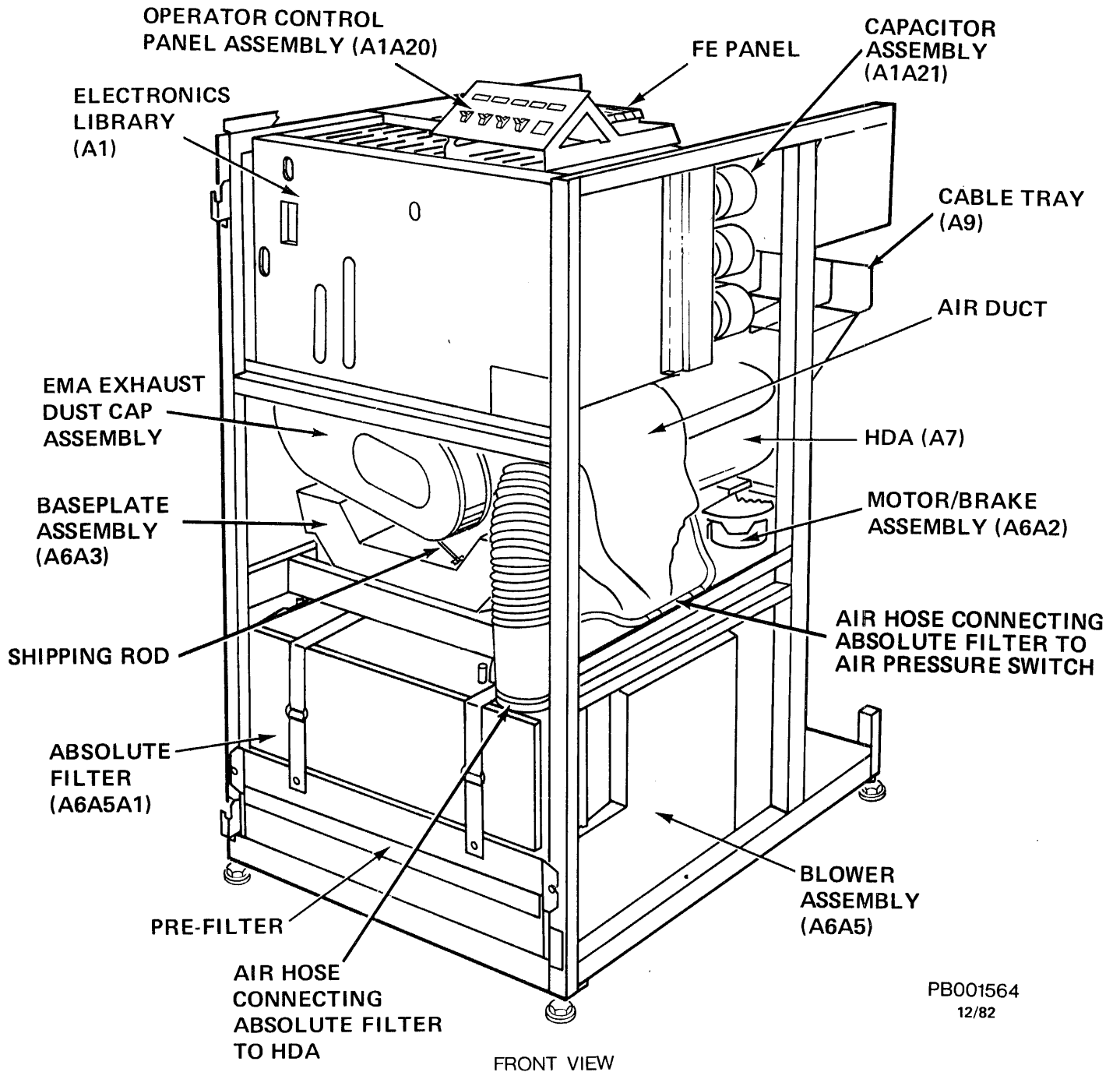

Figure 4-2-12-2 Air Hose (HDA/Absolute Filter)

#### **NOTE**

The replacement air hose should be environmentally clean and capped at both ends, thus preventing contaminants from entering it. DO NOT remove air hose capping material before requested to do so.

1. Obtain permission to disrupt customer operations. Place drive ONLINE/OFF-LINE switch to OFFLINE.
2. Place START/STOP switch in the STOP position.
3. Open the drive front door.
4. Remove the electronics library cover by loosening (DO NOT REMOVE) the screws in the keyhole slots. Lift the library cover up and away from the drive.
5. Set the MASSBUS ENABLE/DISABLE switch to DISABLE (down).
6. Set the SERVICE switch OFF.
7. At the rear of the drive, raise top cover to its detent position. Open drive rear door.
8. Set CB3, CB2, and CB1 OFF in that order.
9. At the front of the drive remove the shield cover assembly by inserting a narrow pointed object (narrow blade screwdriver) into the upper center of the shield. By applying pressure downward, the retainer clip will release. Pull down on the shield and slide it off.
10. Loosen (DO NOT REMOVE) the absolute filter air hose clamp that secures the air hose to the absolute filter discharge port.

#### **NOTE**

The replacement air hose must be on hand, ready for immediate installation, before removing existing air hose. Note the airflow (arrow) direction (pointing up) for correct installation.

11. Remove existing air hose from the absolute filter discharge port. (Immediately proceed to Step 12.)
12. Remove the protective cap from the bottom end of replacement air hose, and install hose onto the absolute filter discharge port. Tighten air hose clamp.
13. Loosen (DO NOT REMOVE) the clamp that secures the air hose to the HDA air nozzle.

14. Remove the existing air hose from the HDA air nozzle. (Immediately proceed to Step 15.)
15. Remove the protective cap from the replacement air hose and install onto the HDA air nozzle. Tighten the air hose clamp securely.
16. Reposition air hose (if necessary) to keep hose from chafing against any solid object (baseplate or frame).
17. Discard used air hose.
18. Set CB1 ON (activating air system).
19. Allow at least five minutes purge time before proceeding to Step 20.
20. Set CB2, CB3 and the SERVICE switch ON in that order. Set MASSBUS ENABLE/DISABLE switch to ENABLE.
21. Replace electronics library cover.
22. Close drive front and rear doors, and top cover.
23. Place START/STOP switch to the START position.
24. Perform "Power On Start" procedure.

#### **4.2.13 Crash Stop Assembly (P/N 9025636-02)**

The Crash Stop Assembly (see Figure 4-2-13-A) is located within the EMA Magnet Assembly (A1). Before the Crash Stop Assembly can be removed, the EMA Magnet Assembly must be removed from the drive.

Removing and replacing the EMA Magnet Assembly requires first, repositioning the HDA.

This procedure requires the following tools:

- A VOM/1.5 volt DC battery
- Plastic tie wrap or minimum 6" length of stout cord, tied in a loop
- Screwdriver
- Air nozzle cap
- Small plastic bag (to cap the air hose)
- Tape (electrical tape preferred)

#### **NOTE**

In the event a spare Air Nozzle Cap or bag is not available, a clean suitable material must be substituted (to plug the HDA air nozzle and air hose).

1. Obtain permission to disrupt customer operations. Place drive ONLINE/OFFLINE switch to OFFLINE. Place the START/STOP switch to STOP.

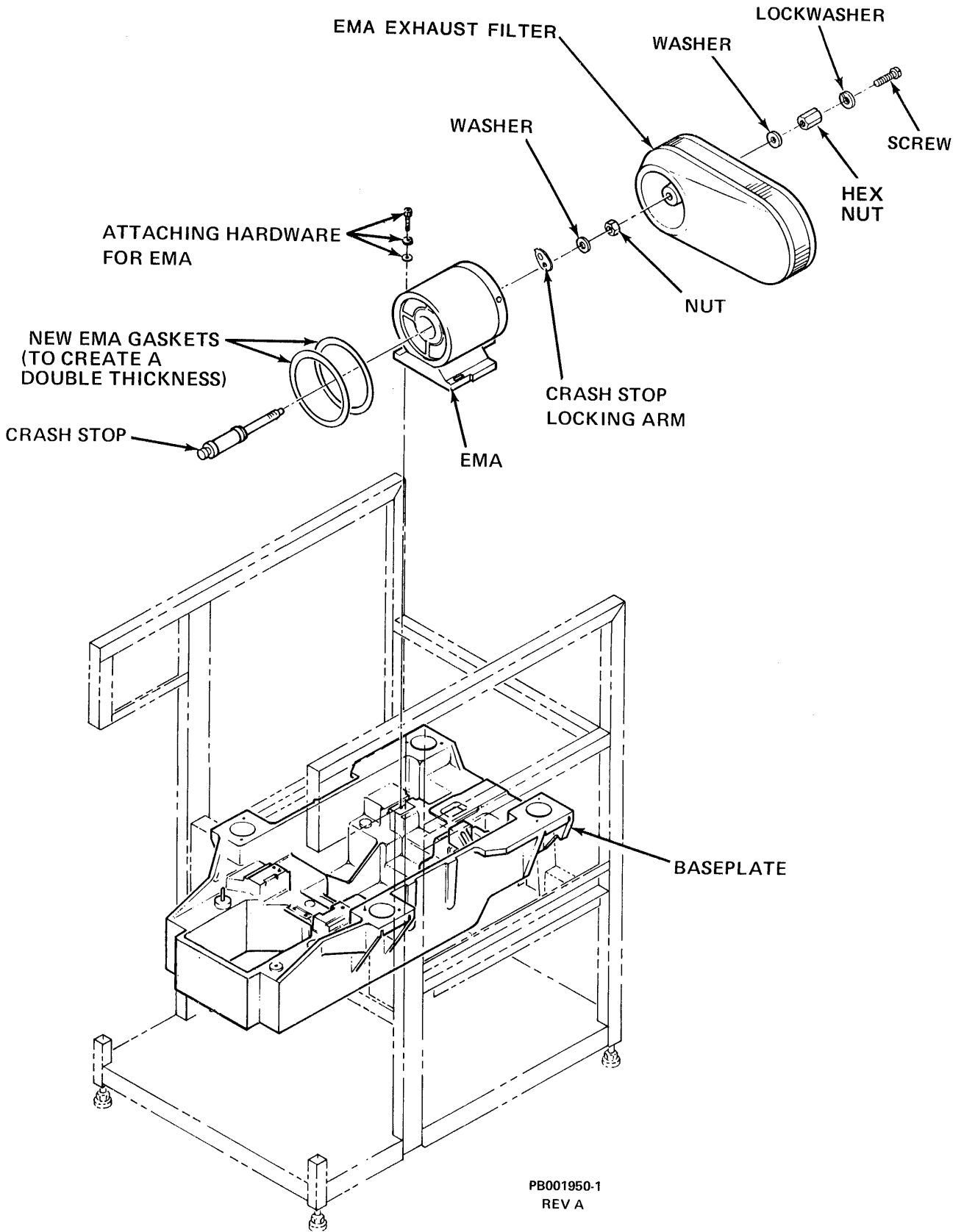

Figure 4-2-13-A Crash Stop Assembly

2. Open drive top cover to its detent position. Open drive front and rear doors. Remove the electronics library cover by loosening (DO NOT REMOVE) two screws in keyhole slots. Lift library cover up and away from drive.
3. Place the MASSBUS ENABLE/DISABLE switch to DISABLE and the SERVICE switch (A1A3) to OFF.
4. Set CB3, CB2 and CB1 OFF in that order.

**NOTE**

Before disconnecting E1 and E2 EMA leads (Step 4), label each lead (both ends) with its reference designations. This will insure reinstalling E1 and E2 EMA leads in the exact physical orientation as removed.

5. At the rear of the drive, disconnect EMA leads E1 and E2 from the backpanel.
6. Set CB1, CB3 and the SERVICE switch ON in that order. Place the START/STOP switch to the START position.

**CAUTION**

Placing CB1 and SERVICE switch ON, START/STOP switch to START allows the stack to spin. Damage to the HDA could result if the stack is not spinning while moving the HDA carriage in Step 7.

**WARNING**

CB2 must remain OFF to avoid personal injury while working in the vicinity of the EMA Magnet Assembly.

7. Connect a VOM/1.5 volt DC battery across E1 and E2 EMA leads.

**NOTE**

Verify that carriage moves toward spindle. If carriage does not move toward spindle, reverse leads. Tape leads to VOM/battery.

8. At the front of the drive remove the shield cover assembly by inserting a narrow pointed object (narrow blade screwdriver) into the upper center of the shield. By applying pressure, the retainer clip will release. Pull down on the shield and slide it off.
9. Remove the EMA Exhaust Filter.

10. Loosen crash stop nut and turn crash stop indicator arm to the "HDA REMOVAL" position (see Figure 4-2-13-B).

**NOTE**

Turning crash stop indicator arm to the "HDA REMOVAL" position allows the carriage to move an additional one-half inch toward the spindle.

11. With the carriage extended towards the spindle, place START/STOP switch in the STOP position.
12. When stack stops spinning, set the SERVICE switch, CB3 and CB1 OFF in that order.
13. At the rear of the drive, remove the belt guard and belt extension spring. (A looped tie wrap or cord can be used to pull the belt extension spring off the back stud.) See Figure 4-2-13-C.
14. Remove keeper plate from the end of the alignment pin. (Pulling the keeper plate up and toward the front of the drive will aid in its removal.) (Reference Figure 4-2-13-C.)

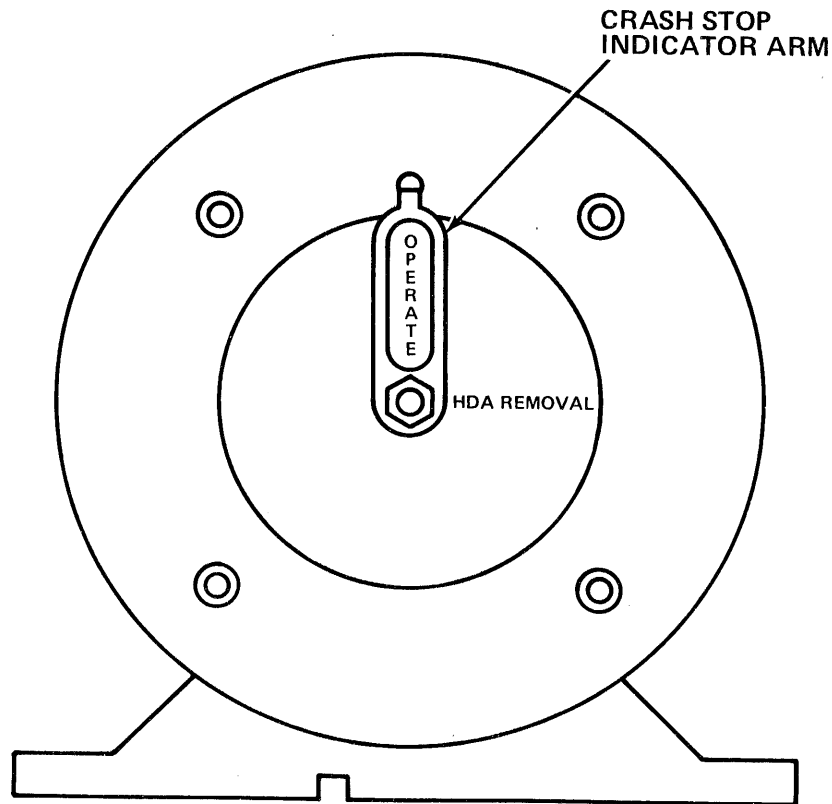

Figure 4-2-13-B Crash Stop Indicator Arm

**NOTE**

Before proceeding to Step 15, the following items should be on hand:

1. Small plastic bag containing air nozzle cap. (Both will be used.)
2. Air Nozzle Cap

In the event the above items are not available, a clean, suitable (lint-free) material must be substituted to plug the HDA air nozzle and air hose. DO NOT use the plastic caps from a replacement/spare HDA.

15. Loosen (DO NOT REMOVE) HDA air hose clamp (see Figure 4-2-13-C). Slip air hose off the HDA and cap HDA air nozzle with the air nozzle cap. Immediately place small plastic bag over the air hose.

**NOTE**

Capping the HDA air nozzle and air hose will prevent dirt and dust from entering the HDA.

16. Disconnect the ground straps, HDA ribbon cable and its ground strap, and the EMA ground straps.
17. Carefully move HDA back approximately one inch.
18. Pivot motor fully toward rear of drive.
19. At the front of the drive, remove three (3) hexhead screws and washers that secure the EMA magnet to the baseplate. (See Figure 4-2-13-A).

**NOTE**

1. DO NOT place an EMA magnet near magnetic tapes, HDAs, or disk packs when performing Step 20.
2. The EMA Magnet Assembly is heavy. After removal from the drive, place EMA Magnet Assembly on a solid surface (floor) to support its weight.

**CAUTION**

DO NOT bump the HDA coil when removing the EMA from the baseplate, or damage to the HDA coil may result.

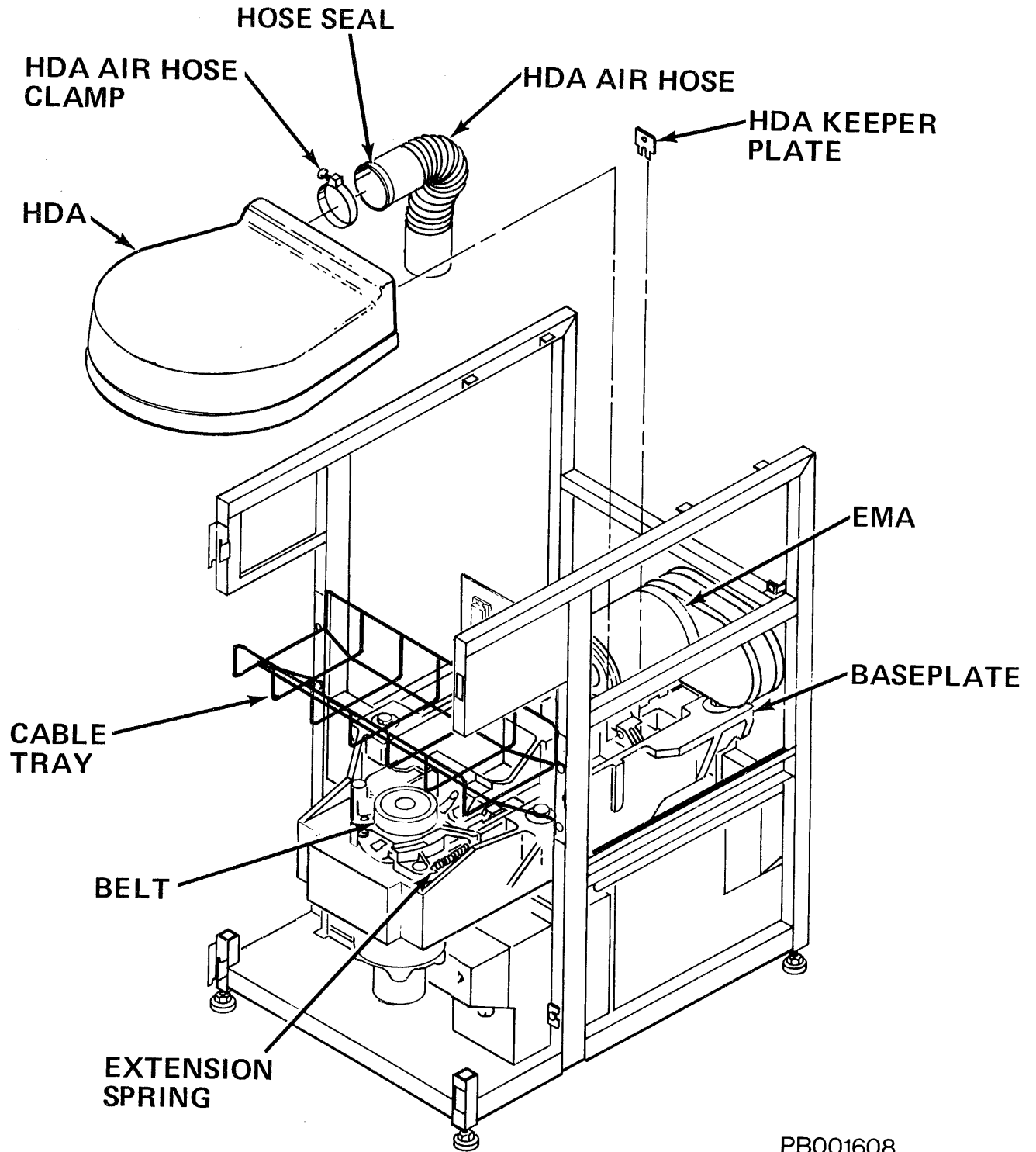

PB001608  
REV A

Figure 4-2-13-C Belt Extension Spring



20. Keeping pressure to the left, slide EMA back towards you as far as it will go, along its guide pins. Carefully lift the EMA straight up, then back and out of the baseplate.

#### **CAUTION**

To avoid HDA contamination (HDA exposed to the environment for too long a period of time), perform the Crash Stop removal and replacement procedure as quickly as possible. (See Figure 4-2-13-A).

#### To remove the Crash Stop Assembly:

1. Remove (and save) the nut, lockwasher and crash stop locking arm from crash stop assembly.
2. Carefully slide crash stop assembly out of the end of EMA.

#### To replace the Crash Stop Assembly:

1. Carefully slide Crash Stop Assembly into the open end of EMA.
2. Install crash stop locking arm, lockwasher and nut. Verify that Crash Stop Locking Arm is in the "HDA REMOVAL" position.
3. Tighten nut finger-tight.

#### To replace the EMA Magnet Assembly:

1. At the rear of the drive, place HDA ribbon cable on top of the HDA (away from the coil).
2. At the front of the drive, place EMA magnet on the baseplate. Lift the EMA 1/2-inch to clear front alignment pins. Slide the EMA magnet forward until it is firmly seated against the rearmost guide pins. Install and tighten the three (3) EMA screws and washers that secure the EMA to the baseplate.

#### **NOTE**

1. Verify that the crash stop indicator arm is still in the "HDA REMOVAL" position.
2. As the EMA approaches the HDA, observe carriage for movement (or continued to be held) towards the spindle. (The magnetic field repels the battery-induced field in the coil.) If this condition does not occur, recheck polarity of the battery.

**NOTE (Cont.)**

3. The EMA magnet must be firmly seated against the rearmost guide pins before performing Step 5. If the magnet is not in correct position, the drive may not be able to access the innermost cylinders.

3. Slowly move HDA toward the EMA.

**NOTE**

When EMA engages the carriage retainer pin, the retainer will rise.

4. Install HDA keeper plate on the alignment pin. (Be sure the lower edge of the HDA keeper plate is sitting on the step of the alignment block.)

**NOTE**

The HDA keeper plate will be loose until the extension spring is installed in Step 6.

5. Center the drive belt on the motor pulley and spindle pulley.

**NOTE**

Insure that belt markings are on the outside of belt before proceeding.

6. Install drive belt extension spring, using a looped tie wrap or cord. Pull spring to the rear stud. Install belt guard.

**NOTE**

Drive belt extension spring must be seated into the grooves of the front and rear studs.

7. Reconnect the ground straps and HDA ribbon cable.

**NOTE**

Verify that CB2 and SERVICE switch are OFF before proceeding.

8. Set CBI ON (activating air system).
9. Remove the plastic bag from air hose.
10. Tap air hose and absolute filter housing to dislodge any possible contaminants.
11. Allows at least five (5) minutes purge time before proceeding.

12. Temporarily set CB1 OFF. Remove air nozzle cap from the HDA air nozzle. Install air hose on HDA air nozzle. Reposition air nose (if necessary) to keep hose from chafing against any solid object (baseplate or frame). Tighten air hose clamp. Set CB1 ON.
13. Allow an additional five (5) minutes purge time before proceeding.
14. Set CB3 and the SERVICE switch ON.
15. Place START/STOP switch to the START position. After the stack has come up to speed, reverse the leads to the VOM/battery. Tape the leads.
16. Visually observe that carriage is in its fully retracted position (towards EMA).
17. With the carriage in its fully retracted position, turn crash stop indicator arm to the "OPERATE" position. Tighten crash stop nut.
18. Replace EMA Exhaust Filter on the back of the EMA.

**NOTE**

Carriage should now be resting  
against the outer crash stop.

19. Reverse E1 and E2 EMA leads at the VOM/battery and visually confirm the carriage travels in a smooth, even motion toward the spindle.
20. Remove the VOM/battery and visually confirm that the carriage travels back toward EMA with a smooth even motion.
21. Reverse battery leads, placing them across E1, E2 EMA leads. Visually confirm that the carriage fully retracts to the outer crash stop.
22. Place START/STOP switch in the STOP position. When stack stops spinning set the SERVICE switch, CB3, and CB1 OFF in that order.
23. Disconnect VOM/battery and connect E1, E2 EMA leads to the backpanel.
24. At the front of the drive replace the shield cover assembly.
25. Set CB1, CB2 and CB3 ON in that order.
26. Set the SERVICE switch ON. Set the MASSBUS ENABLE/DISABLE switch to ENABLE.
27. Replace the electronics library cover, and tighten two screws in keyhole slots. Close all drive covers and doors.
28. Place START/STOP switch in the START position.
29. Perform "Power On Start" procedure.
30. Resume customer operations.

#### 4.2.14 Blower Assembly (A5) (P/N 9046140-00, -01)

The following procedure describes the removal and replacement of the Blower Assembly. To facilitate removal of the Blower Assembly, the prefilter and Absolute Filter (A6A5A1) will be removed first. (See Figure 4-2-14-A.)

This procedure requires the following tools:

- Screwdriver
  - Cap for the filter air pressure tap
  - Air nozzle cap for HDA air nozzle
  - Small plastic bag (to seal the large air hose)
  - Capping material for the absolute filter intake port. (Capping material consists of any clean suitable material, to plug the absolute filter intake port.)
  - Sheet of thin cardboard or sheet metal (optional, to protect the foam gasket at the top of the Blower Assembly during replacement).
1. Obtain permission to disrupt customer operations. Place drive ONLINE/OFF-LINE switch to OFFLINE.
  2. Place START/STOP switch in the STOP position.
  3. Open and remove the drive front door.
  4. Loosen (DO NOT REMOVE) the two screws located in the keyhold slots that secure the electronics library cover to the library cage. Lift the cover up and away from the drive.
  5. Set the MASSBUS ENABLE/DISABLE switch to DISABLE (down).
  6. Set the SERVICE switch OFF.
  7. At the rear of the drive, raise top cover and open drive rear door.
  8. Set CB3, CB2 and CB1 OFF in that order.
  9. Disconnect the BLOWER (power) plug connector from J3 on the AC Power Distribution Assembly (A6A2).
  10. At the front of the drive remove the shield cover assembly by inserting a narrow pointed object (narrow blade screwdriver) into the upper center of the shield. By applying pressure, the retainer clip will release. Pull down on the shield and slide it off.
  11. Slide the prefilter out of its housing in the Blower Assembly, set it aside.
- NOTE**  
Visually inspect prefilter for dirt accumulation. If replacement is necessary, see Subsection 4.2.2 of this manual.
12. Unbuckle the absolute filter retaining straps. (DO NOT remove the Absolute Filter at this time.)

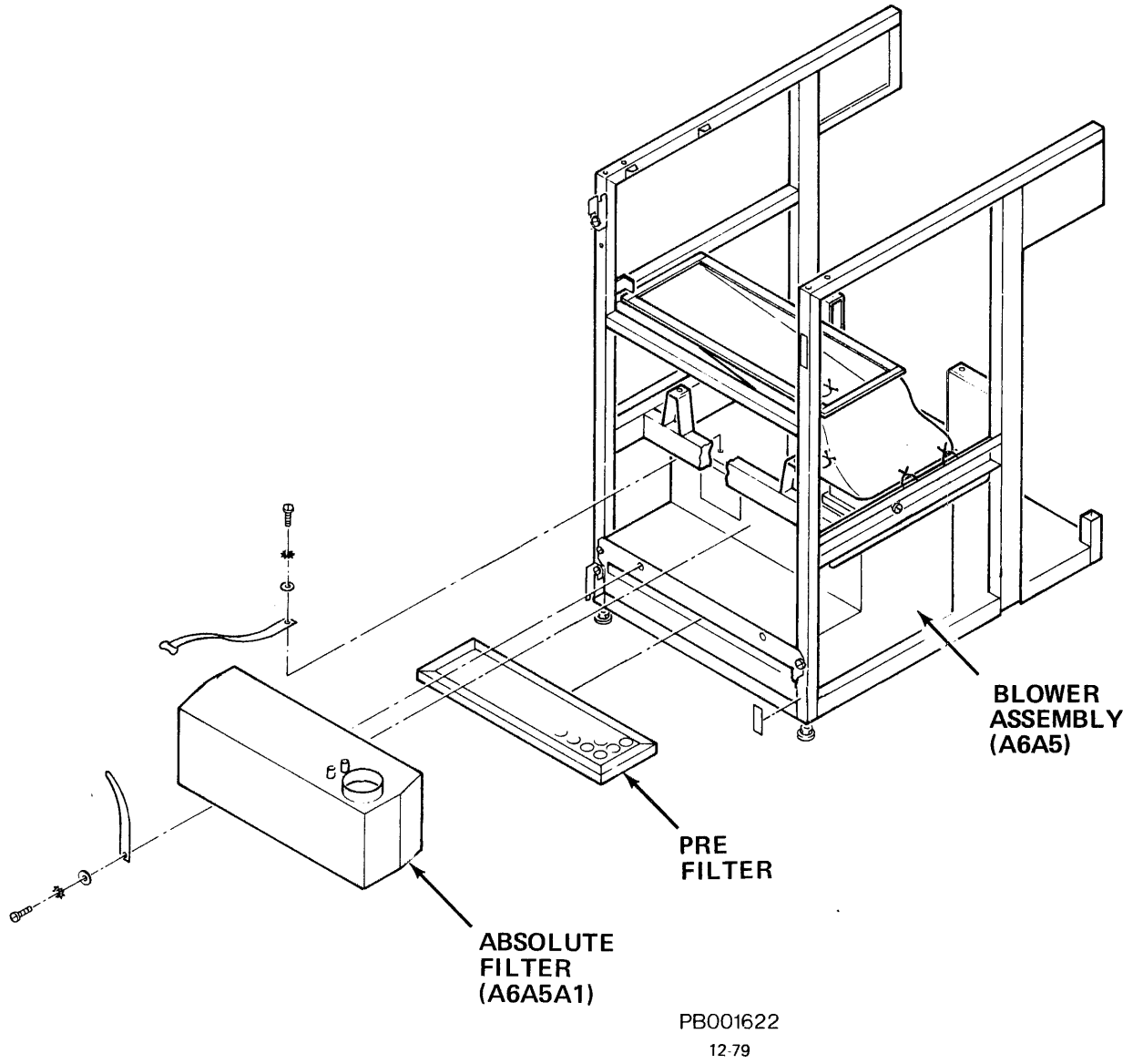

Figure 4-2-14-A Blower Assembly and Filters

**NOTE**

The absolute filter will be removed from the drive with the large air hose connected to it.

13. Remove (clear plastic) air hose tubing from the absolute filter air pressure tap and install protective cap on the absolute filter air pressure tap. See Figure 4-2-14-B.
14. Loosen (DO NOT REMOVE) air hose clamp that secured HDA air hose to the Absolute Filter discharge opening.
15. Remove HDA air hose from HDA air nozzle. Cap HDA air nozzle with air nozzle cap. Cap HDA air hose with plastic bag.
16. Remove absolute filter (air hose attached), and immediately cap the absolute filter intake port, set down on clean surface.
17. Remove (and save) two self-tapping screws and lockwashers from the lower front corners of Blower Assembly.

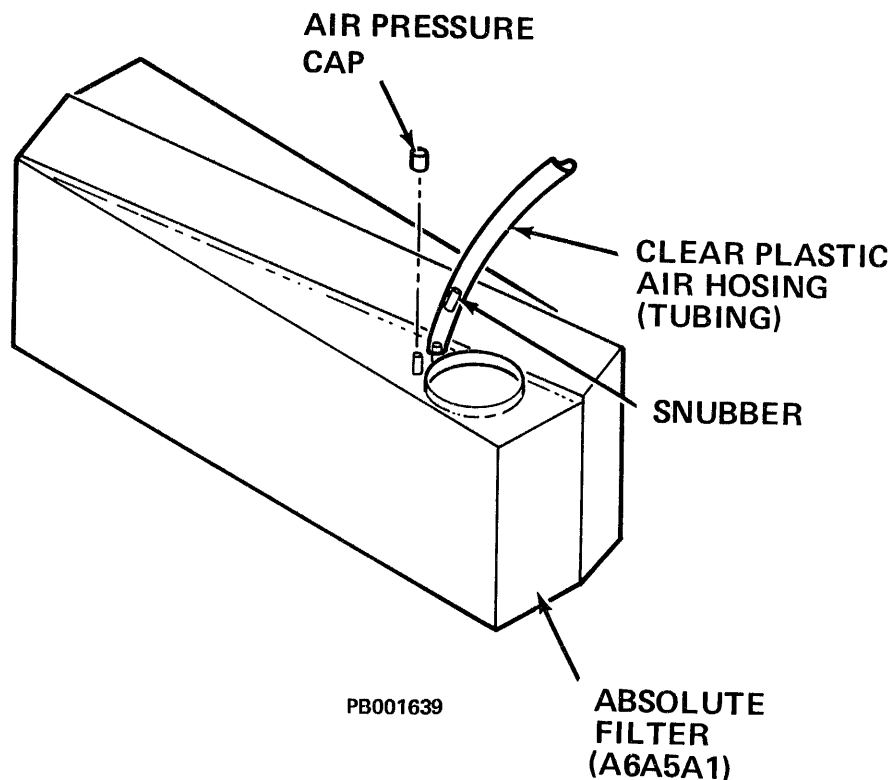

Figure 4-2-14-B Absolute Filter (Air Pressure Taps)

### **CAUTION**

To avoid damage to Blower (power) cord and plug, exercise care when moving Blower Assembly out of the drive frame.

18. Pull Blower Assembly straight out of the drive.
19. Remove and retain the two sets of absolute filter retaining straps from the old Blower Assembly.

### **Replacing the Blower Assembly:**

1. Attach the two sets of absolute filter retaining straps to the replacement Blower Assembly.
2. Slide replacement Blower Assembly into drive frame until edge of plenum comes in contact with the foam gasket material on top of the blower housing.

### **NOTE**

Step 3 uses the (optional) sheet of cardboard or sheet metal to protect the foam gasket at the top of the Blower Assembly. Disregard if not applicable.

3. Carefully tuck in foam beneath plenum intake flange. (A thin sheet of cardboard, or sheet metal can be placed on top of the flange to minimize damage to the foam.)

### **CAUTION**

Exercise care when installing Blower Assembly into the drive frame (Step 4). DO NOT damage power cord or plug.

4. Slowly push Blower Assembly all the way back into place. Tuck in the foam gasket material at the other end of the plenum.

### **NOTE**

Remove cardboard or sheet metal, if installed in Step 3.

5. Install and tighten two self-taping screws and lockwashers at the lower front corners of Blower Assembly.
6. Remove cap from Absolute Filter intake port and replace Absolute Filter into the Blower Assembly.

7. Buckle Absolute Filter retaining straps. (Pull the retaining straps until the filter is securely seated in the blower assembly.)
8. Remove cap from HDA air nozzle and remove plastic bag from air hose. (Immediately proceed to Step 9.)
9. Install air hose on the HDA air nozzle. Tighten air hose clamp securely.
10. Remove cap from the Absolute Filter air pressure port. Attach (clear plastic) air pressure hose (tubing) onto the innermost tap of the Absolute Filter. (See Figure 4-2-14-B.)

**NOTE**

Be sure to replace prefilter (Step 12) with airflow arrows pointing up.

11. Reposition air hose (if necessary) to keep hose from chafing against any solid object (baseplate or frame).
12. Slide prefilter into its housing in the Blower Assembly.
13. At the rear of the drive, connect Blower power plug connector into J3 connector on the AC Power Distribution Assembly (A6A2).

**NOTE**

Air pressure measurements should be taken after replacing the Blower Assembly. The following procedure provides the recommended method of taking air pressure measurements using the (optional) Air Pressure Gauge Assembly, and Air Pressure Gauge Adapter hose.

Air Pressure Check:

The following tools are recommended for this procedure:

- Air Pressure Gauge Assembly
  - Air Pressure Gauge Adapter Hose
1. With the START/STOP switch OFF, set CBI ON.
  2. Remove the air pressure cap from the outermost air pressure tap, located on top of the Absolute Filter. (See Figure 4-2-14-B.)
  3. Attached the Air Pressure Gauge Adapter Hose to the air pressure tap.

**NOTE**

Fitting end of Air Pressure Gauge Adapter Hose mates with Air Pressure Gauge Assembly.



4. Connect the Air Pressure Gauge Assembly.
5. Record the exhaust pressure. Refer to Table 4-2-14. The exhaust pressure of the Absolute Filter should be at least that shown in the Air Pressure Records. If the exhaust pressure matches the air pressure records, go to Step 6. If the exhaust pressure is less than shown, change the Prefilter (if replacement was not done earlier in this procedure). If the exhaust pressure is still not at the required level, replace the Absolute Filter (see Subsection 4.2.3 of this manual).

Table 4-2-14 Air Pressure Records

INSTALLATION ALTITUDE		MINIMUM BLOWER PRESSURE AT INSTALLATION INCHES/H <sub>2</sub> O	REPLACE FILTER BEFORE PRESSURE RECORDS INCHES/H <sub>2</sub> O
(FEET)	(METERS)		
0	0	2.50	2.10
1000	305	2.42	2.03
2000	610	2.35	1.97
3000	914	2.28	1.90
4000	1219	2.21	1.84
5000	1524	2.14	1.78
6000	1829	2.07	1.71
7000	2134	2.01	1.66
8000	2438	1.94	1.61
9000	2743	1.88	1.55
10000	3048	1.82	1.50

Installation Altitude \_\_\_\_\_

Installation Air Pressure \_\_\_\_\_

6. Set CB1 OFF.
7. Remove Air Pressure Gauge Assembly and Adapter Hose from the air pressure tap.
8. Replace the air pressure cap on the Absolute Filter air pressure tap.
9. Set CB1, CB2 and CB3 ON in that order.
10. Set the SERVICE switch ON. Set MASSBUS ENABLE/DISABLE switch to ENABLE.
11. Replace electronics library cover.
12. Close the drive rear door and the top cover.
13. Replace and close drive front door.
14. Place START/STOP switch to the START position.

15. Resume customer operations.

#### **4.2.15 Spindle Ground Assembly (P/N 9026235-01)**

The following procedure describes the removal and replacement of Spindle Ground Assembly. See Figure 4-2-15-A. Before Spindle Ground Assembly can be removed, the Motor Brake Assembly must be removed first.

This procedure requires the following tool:

- Offset Screwdriver
1. Obtain permission to disrupt customer operations. Place drive ONLINE/OFF-LINE switch to OFFLINE.
  2. Place START/STOP switch in the STOP position.
  3. Open the drive front door.
  4. Loosen (DO NOT REMOVE) the screws located in the keyhole slots that secure the electronics library cover to the library cage. Lift the cover up and away from the drive.
  5. Set the MASSBUS ENABLE/DISABLE switch to DISABLE (down).
  6. Set the SERVICE switch OFF.
  7. At rear of drive, raise the top cover, open the rear door.
  8. Set CB3, CB2 and CB1 OFF in that order.

#### **WARNING**

CB1 must be OFF to avoid personal injury when removing this assembly.

9. Disconnect motor/brake plug connector A3M1P4 from J4 located on the A2 assembly (AC Power Distribution Assembly). See Figure 4-2-15-B.
10. Remove belt guard and belt extension spring (a looped plastic tie wrap or cord can be used to pull belt extension spring off back stud).
11. From the rear of drive, loosen and remove rear screw (only screw accessible with standard screwdriver) from Delrin motor mount guide.
12. Pivot motor mount guide to right as far as it will go.
13. Remove and save retaining ring (C clip) from motor mount pivot stud.

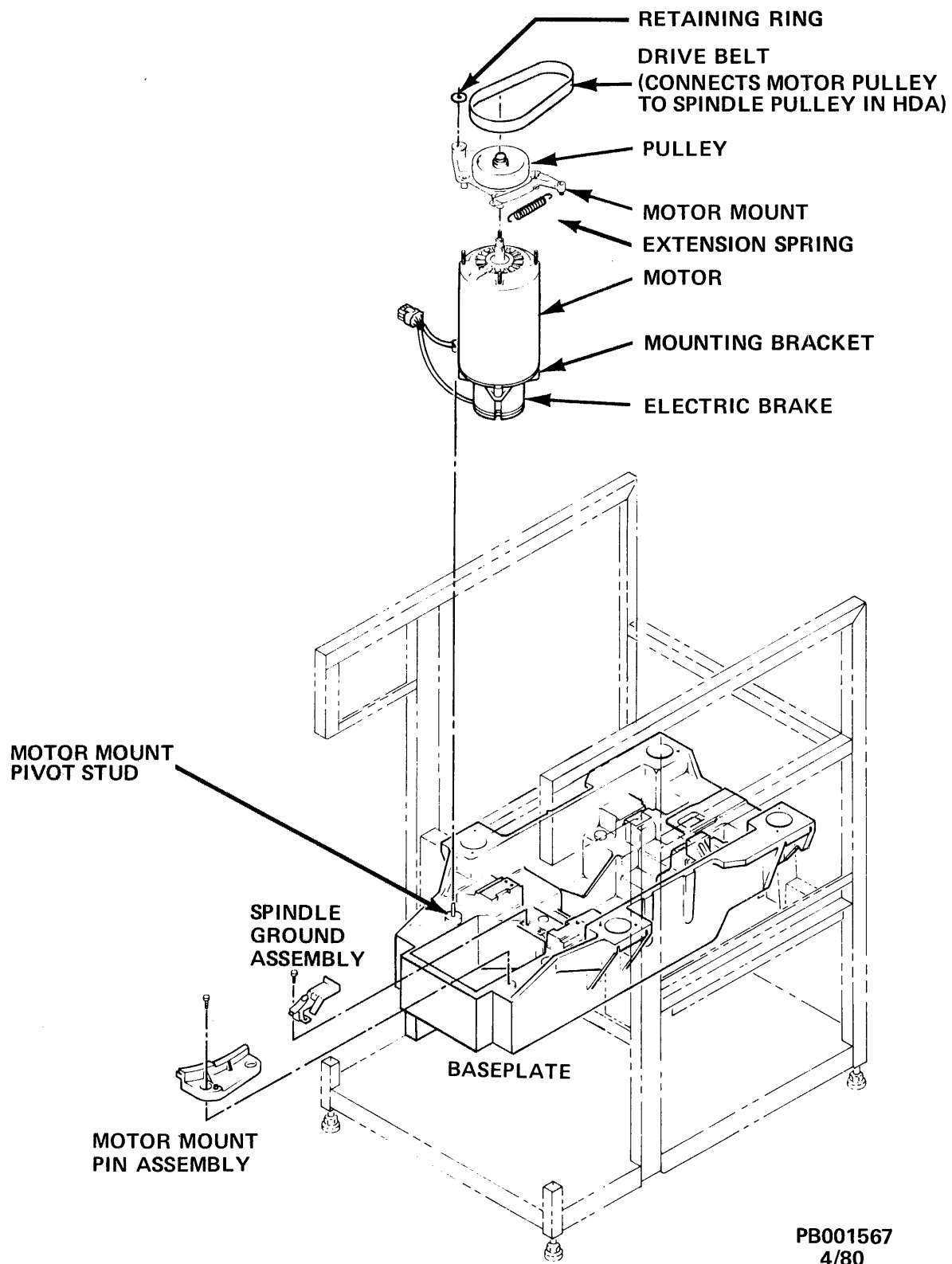
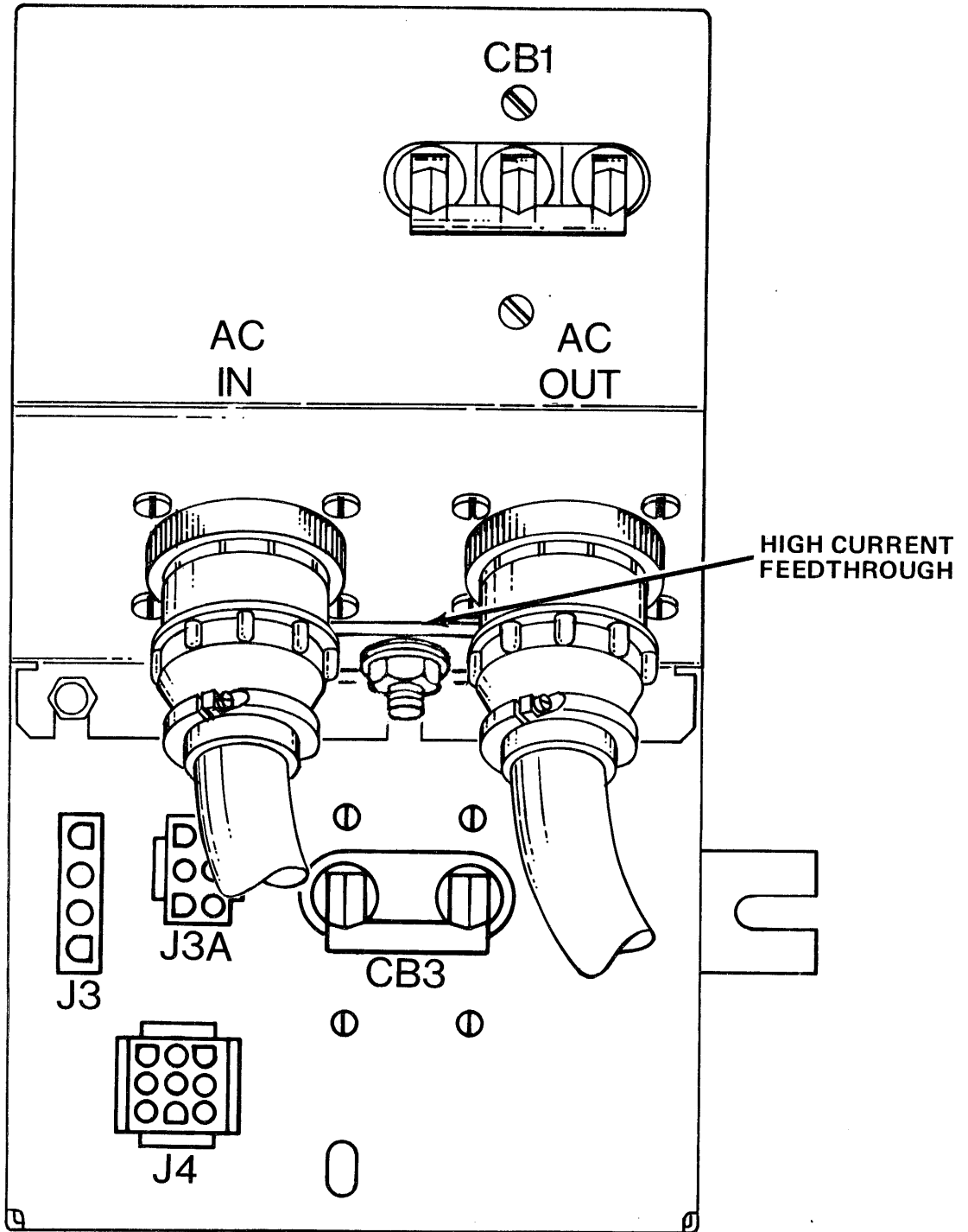

Figure 4-2-15-A Spindle Ground Assembly



PB001314-2  
12/79

Figure 4-2-15-B AC Power Distribution Assembly (Front View)

### **CAUTION**

Use care not to bump the HDA when lifting the Drive Motor/Brake Assembly or damage to the HDA may result.

14. Lift the belt above the drive motor pulley.
15. Pivot motor mount toward rear of drive keeping motor shaft in good vertical alignment, then lift motor mount up approximately one inch, to clear pin, and rotate it clockwise (as observed from above), away from the pin. Carefully tilt the lower motor assembly down and through the baseplate (pivot end first).
16. Using offset screwdriver, remove two screws that secure Spindle Ground Assembly to drive baseplate. (See Figure 4-2-15-A.)
17. Remove the Spindle Ground Assembly from the drive.

#### To replace the Spindle Ground Assembly:

1. Place Spindle Ground Assembly onto baseplate.
2. Secure the Spindle Ground Assembly to the baseplate with two screws (using offset screwdriver).

#### To replace the Drive Motor/Brake Assembly:

### **NOTE**

Before placing motor assembly into baseplate, position motor assembly with pivot end of motor mount toward rear of drive.

1. Supporting the motor, carefully position then tilt and lift the motor the assembly up through its mounting hole in baseplate.

### **NOTE**

Tilting motor assembly allows pivot end of motor mount to pass through the baseplate.

2. Pivot motor mount counterclockwise (as observed from above) and lift motor mount up and set pivot end of motor mount down onto pin.
3. Pivot motor mount toward front of drive.
4. Replace retaining ring (C clip) onto motor mount pivot stud.
5. Pivot motor mount guide to left as far as it will go.
6. Replace and tighten screw removed from Delrin motor mount guide.

7. Reconnect motor/brake plug connector A3M1P4 into J4 located on the AC Power Distribution Assembly (A2).

**CAUTION**

Using a replacement Drive Motor/ Brake Assembly that rotates clockwise WILL DESTROY the HDA.

The following procedure includes a check of the replacement Motor/Brake Assembly rotational spin.

**CAUTION**

Follow this procedure step-by-step to avoid HDA damage when a Drive Motor/Brake Assembly has been replaced.

1. Verify CB1 is OFF.
2. Set the SERVICE switch and CB3 ON.
3. Place the START/STOP switch in the START position.

**WARNING**

To avoid personal injury, DO NOT touch the motor pulley or motor brake while performing the following steps:

4. Push the body of the drive motor toward the front of the drive.

**CAUTION**

Be sure drive belt is not dressed around drive motor pulley.

5. Set CB1 ON. Drive motor will start in approximately 30-45 seconds (initialization routine execution time).
6. Observe that the starting torque forces the motor away from the spindle and toward the rear of the drive.

**NOTE**

Motor pulley rotation may be visually observed as the motor stops when CB1 is set OFF in the following step.

### **CAUTION**

A drive motor that rotates in the wrong direction will torque towards the spindle. If this occurs the belt tension spring must NOT be installed and a new drive motor assembly must be installed.

7. Set CB1 OFF. Set CB3 and SERVICE switch OFF. Set START/STOP switch to STOP.
8. Dress the belt around the drive motor pulley.
9. Install drive belt extension spring using a looped (plastic) tie wrap or cord. Pull spring to rear stud. Install belt guard.

### **NOTE**

Drive belt extension spring must be seated into the grooves of the front and rear studs.

10. Set CB1, CB2 and CB3 ON in that order.
11. Close drive rear door and top cover.
12. Set SERVICE switch ON. Set MASSBUS ENABLE/DISABLE switch to ENABLE.
13. Replace electronics library cover.
14. Place START/STOP switch in START position.
15. Perform "Power On Start" procedure. Resume customer operations.

#### **4.2.16 Drive Motor Belt (P/N 9001856-02)**

This procedure requires the following tools:

- Tie Wrap or Cord
  - Side-cutters (to cut old belt)
1. Obtain permission to disrupt customer operations. Place drive ONLINE/OFFLINE switch to OFFLINE.
  2. Place START/STOP switch in the STOP position.
  3. Open the drive front door.
  4. Loosen (DO NOT REMOVE) two (2) screws located in the keyhole slots that secure the electronics library cover to the library cage. Lift the library cover up and away from the drive.
  5. Set the MASSBUS ENABLE/DISABLE switch to DISABLE (down).

6. Set the SERVICE switch OFF.
7. At the rear of drive, raise the top cover, open the rear door.
8. Set CB3, CB2 and CB1 OFF in that order.

**WARNING**

CB1 must be OFF to avoid personal injury when removing this assembly.

9. Disconnect motor/brake plug connector A3M1P4 from J4 located on the AC Power Distribution Assembly (A2). See Figure 4-2-16.
10. Remove belt guard and belt extension spring (a looped plastic tie wrap or cord can be used to pull belt extension spring off back stud).
11. From the rear drive, loosen and remove rear screw with standard from Delrin motor mount guide.
12. Pivot motor mount guide to right as far as it will go.
13. Remove and save retaining ring (C clip) from motor mount pivot stud. (See Figure 4-2-15-A.)

**CAUTION**

Use care NOT to bump the HDA when lifting the Drive Motor/Brake Assembly or damage to the HDA may result.

14. Lift the belt above the drive motor pulley.
15. Pivot motor mount toward rear of drive keeping motor shaft in good vertical alignment, then lift motor mount up approximately one inch, to clear pin, and rotate it clockwise (as observed from above), away from the pin. Carefully tilt and lower motor assembly down through the baseplate (pivot end first).
16. Remove the drive motor belt and discard it.

To replace Drive Motor Belt:

**NOTE**

1. Insure that belt markings are on the outside of replacement belt before installing.
2. Check belt markings for 50 HZ or 60 Hz drive belt part number. Reference Illustrated Parts Breakdown for correct belt part number.



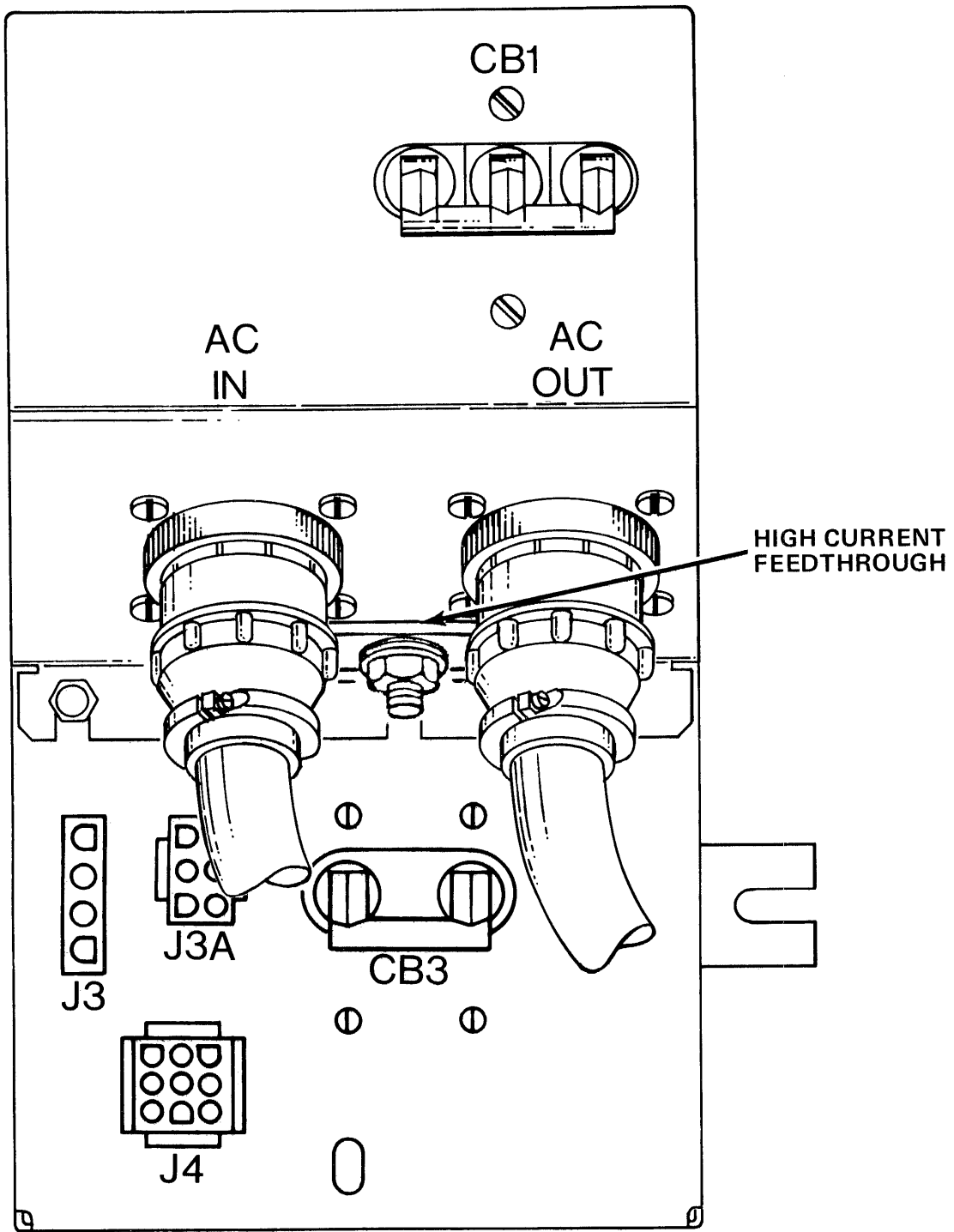

PB001314-2  
12/79

Figure 4-2-16 AC Power Distribution Assembly (Front View)

1. Carefully slip the drive motor belt between the spindle and the spindle ground button. Use extreme care not to bend the spindle ground button spring.

To replace the Drive Motor/Brake Assembly:

**NOTE**

Before placing motor assembly into baseplate, position motor assembly with pivot end of motor mount toward rear of drive.

1. Supporting the motor, carefully position then tilt and lift the motor assembly up through its mounting hole in baseplate.

**NOTE**

Tilting motor assembly allows pivot end of motor mount to pass through the baseplate.

2. Pivot motor mount counterclockwise (as observed from above) and lift motor mount up and set pivot end of motor mount down onto pin.
3. Pivot motor mount toward front of drive.
4. Replace retaining ring (C clip) onto motor mount pivot stud.
5. Pivot motor mount guide to left as far as it will go.
6. Replace and tighten screw removed from Delrin motor mount guide.
7. Reconnect motor/brake plug connector A3M1P4 into J4 located on the AC Power Distribution Assembly (A2).

**CAUTION**

Using a replacement Drive Motor/ Brake Assembly that rotates clockwise WILL DESTROY the HDA.

The following procedure includes a check of the replacement Motor/Brake Assembly rotational spin.

**CAUTION**

Follow this procedure step-by-step to avoid HDA damage when a Drive Motor/Brake Assembly has been replaced.

1. Verify CBI is OFF.

2. Set the SERVICE switch and CB3 ON.
3. Place the START/STOP switch in the START position.

**WARNING**

To avoid personal injury, DO NOT touch the motor pulley or motor brake while performing the following steps:

4. Push the body of the drive motor toward the front of the drive.

**CAUTION**

Be sure drive belt is not dressed around drive motor pulley.

5. Set CB1 ON. Drive motor will start in approximately 30-45 seconds (initialization routine execution time).
6. Observe that the starting torque forces the motor away from the spindle and toward the rear of the drive.

**NOTE**

Motor pulley rotation may also be visually observed as the motor stops when CB1 is set OFF in the following step.

**CAUTION**

A drive motor that rotates in the wrong direction will torque towards the spindle. If this occurs, the belt tension spring must NOT be installed and a new drive motor assembly must be installed.

7. Set CB1 OFF. Set CB3 and SERVICE switch OFF. Set START/STOP switch to STOP.
8. Dress the belt around the drive motor pulley.
9. Install drive belt extension spring using a looped (plastic) tie wrap or cord. Pull spring to rear stud. Install belt guard.

#### **NOTE**

Drive belt extension spring must be seated into the grooves of the front and rear studs.

10. Set CB1, CB2 and CB3 ON in that order.
11. Close drive rear door and top cover.
12. Set SERVICE switch ON. Set MASSBUS ENABLE/DISABLE switch to ENABLE.
13. Replace electronics library cover.
14. Place START/STOP switch in START position.
15. Perform "Power On Start" procedure. Resume customer operations.

#### **4.2.17 Drive Motor Pulley**

The Motor Pulley which is part of the Drive Motor/Brake Assembly (A6A3M1), is mounted on top of the drive motor (A6A3M1M1). Because of the precise torquing requirements required during (pulley) installations, replacement of the pulley is NOT recommended.

If the motor pulley is defective, replace the Drive Motor/Brake Assembly (see Subsection 4.2.19 of this manual).

#### **4.2.18 Drive Motor Brake (A3M1L1)**

The Drive Motor Brake, part of the Drive Motor/Brake Assembly, is not field replaceable. See Subsection 4.2.19 of this manual for the removal and replacement procedures of the Drive Motor/Brake Assembly.

#### **4.2.19 Drive Motor/Brake Assembly (A3M1) (P/N 9041040-00, 60 Hz; 9041040-01, 50 Hz)**

The following procedure describes the removal and replacement of Drive Motor/Brake Assembly. See Figure 4-2-19-A.

1. Obtain permission to disrupt customer operations. Place drive ONLINE/OFFLINE switch to OFFLINE.
2. Place START/STOP switch in the STOP position.
3. Open the drive front door.
4. Loosen (DO NOT REMOVE) two screws located in the keyhole slots that secure the electronics library cover to the library cage. Lift the cover up and away from the drive.
5. Set the MASSBUS ENABLE/DISABLE switch to DISABLE (down).
6. Set the SERVICE switch OFF.
7. At the rear of drive, raise the top cover and open the rear door.

8. Set CB3, CB2 and CB1 OFF in that order.

**WARNING**

CB1 must be OFF to avoid personal injury when removing this assembly.

9. Disconnect motor/brake plug connector A3M1P4 from J4 located on AC Power Distribution Assembly (A2). See Figure 4-2-19-B.
10. Remove belt guard and belt extension spring (a looped plastic tie wrap or cord can be used to pull belt extension spring off back stud).
11. From the rear of drive, loosen and remove rear screw (only screw accessible with standard screwdriver) from motor mount guide.
12. Pivot motor mount guide to right as far as it will go.
13. Remove and save retaining ring (C clip) from motor mount pivot stud. (See Figure 4-2-19-A).

**CAUTION**

Use care NOT to bump the HDA when lifting the Drive Motor/Brake Assembly or damage to the HDA may result.

14. Lift the belt above the drive motor pulley.
15. Pivot motor mount toward rear of drive keeping motor shaft in good vertical alignment, then lift motor up approximately one inch, to clear pin, and rotate it clockwise (as observed from above), away from the pin. Carefully tilt and lower motor assembly down and through the baseplate (pivot end first).

To replace the Drive Motor/Brake Assembly:

**NOTE**

Before placing motor assembly into baseplate, position motor assembly with pivot end of motor mount toward rear of drive.

1. Supporting the motor, carefully position then tilt and lift the motor assembly up through its mounting hole in baseplate.

**NOTE**

Tilting motor assembly allows pivot end of motor mount to pass through the baseplate.

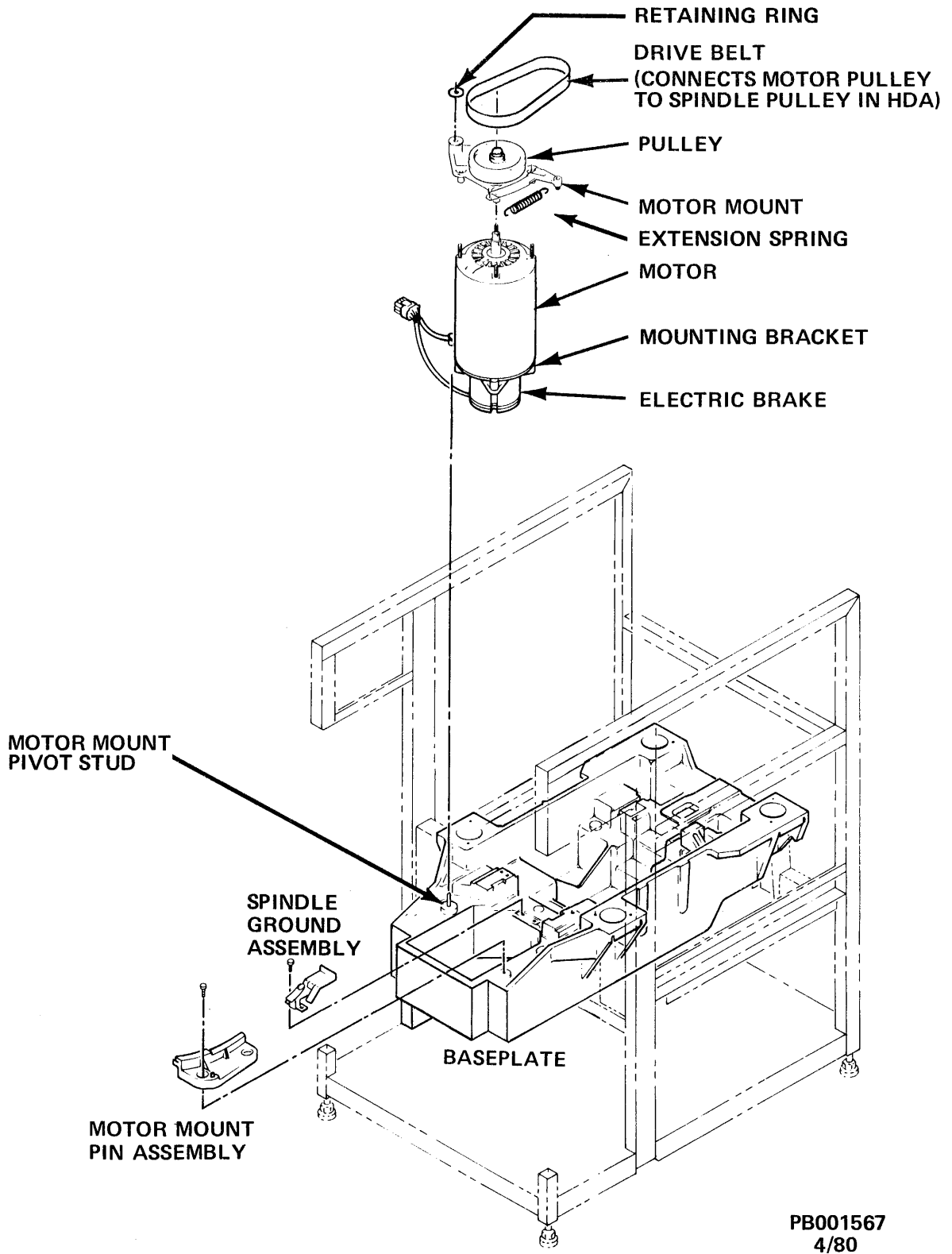
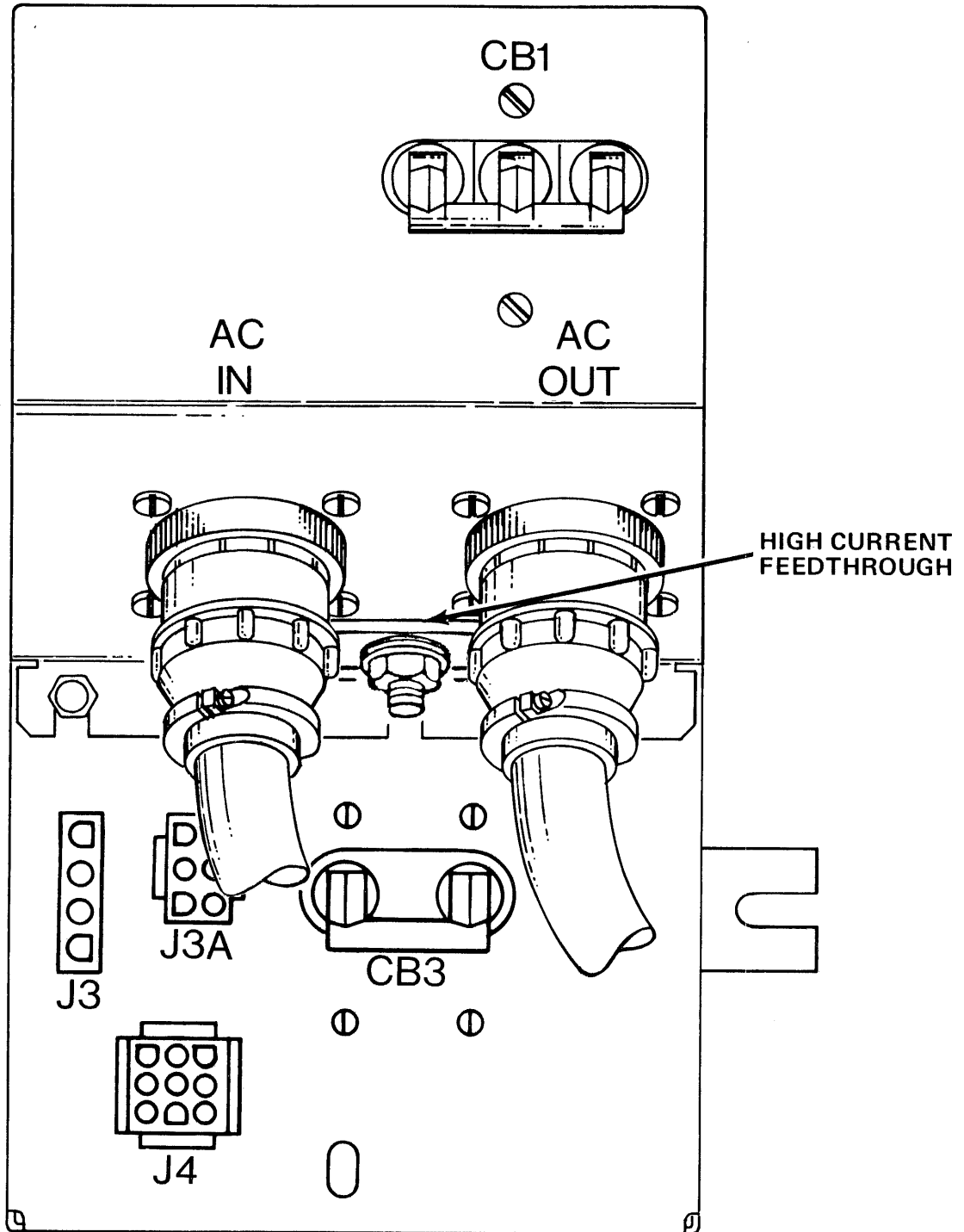

Figure 4-2-19-A Drive Motor/Brake Assembly



PB001314-2  
12/79

Figure 4-2-19-B AC Power Distribution Assembly (Front View)

2. Pivot motor mount counterclockwise (as observed from above) and lift motor mount up and set pivot end of motor mount down onto pin.
3. Pivot motor mount toward front of drive.
4. Replace retaining ring (C clip) onto motor mount pivot stud.
5. Pivot motor mount guide to left as far as it will go.
6. Replace and tighten screw removed from motor mount guide.
7. Reconnect motor/brake plug connector A3M1P4 into J4 located on the AC Power Distribution Assembly (A2).

**CAUTION**

Using a replacement Drive Motor/  
Brake Assembly that rotates clock-  
wise WILL DESTROY the HDA.

The following procedure includes a check of the replacement Motor/Brake Assembly rotational spin.

**CAUTION**

Follow this procedure step-by-step  
to avoid HDA damage when a Drive  
Motor/Brake Assembly has been re-  
placed.

1. Verify CB1 is OFF.
2. Set the SERVICE switch and CB3 ON.
3. Place the START/STOP switch in the START position.

**WARNING**

To avoid personal injury, DO NOT  
touch the motor pulley or motor  
brake while performing the follow-  
ing steps:

4. Push the body of the drive motor toward the front of the drive.

**CAUTION**

Be sure drive belt is not dressed  
around drive motor pulley.



5. Set CB1 ON. Drive motor will start in approximately 30-45 seconds (initialization routine execution time.)
6. Observe that the starting torque forces the motor away from the spindle and toward the rear of the drive.

**NOTE**

Motor pulley rotation may also be visually observed as the motor stops when CB1 is set OFF in the following step.

**CAUTION**

A drive motor that rotates in the wrong direction will torque towards the spindle. If this occurs the belt tension spring must NOT be installed and a new drive motor assembly must be installed.

7. Set CB1 OFF. Set CB3 and SERVICE switch OFF. Set START/STOP switch to STOP.

**NOTE**

If motor pulley rotation was NOT counterclockwise, replace the Drive Motor/Brake Assembly.

8. Dress the belt around the drive motor pulley.
9. Install drive belt extension spring using a looped (plastic) tie wrap or cord. Pull string to rear stud. Install a belt guard.

**NOTE**

Drive belt extension spring must be seated into the grooves of the front and rear studs.

10. Set CB1, CB2 and CB3 ON in that order.
11. Close drive rear door and top cover.
12. Set SERVICE switch ON. Set MASSBUS ENABLE/DISABLE switch to ENABLE.
13. Replace electronics library cover.
14. Place START/STOP switch in START position.
15. Perform "Power On Start" procedure. Resume customer operations.

#### 4.2.20 AC Power Distribution Assembly (A6A2) (P/N 9035671-XX, 60 Hz; 9035671-XX, 50 Hz)

The following procedure describes the removal and replacement of the the AC Power Distribution Assembly. (See Figure 4-2-20-A.)

This procedure requires the following tool:

- o Screwdriver
1. Obtain permission to disrupt customer operations. Place drive ONLINE/OFFLINE switch to OFFLINE.
  2. Place START/STOP switch in the STOP position.
  3. Open the drive front door.
  4. Loosen (DO NOT REMOVE) two screws located in the keyhole slots that secure the electronics library cover to the library cage. Lift the cover up and away from the drive.
  5. Set the MASSBUS ENABLE/DISABLE switch to DISABLE (down).
  6. Set the SERVICE switch OFF.
  7. At the rear of the drive, raise the top cover to its detent position. Open the drive rear door.
  8. Set CB3, CB2 and CB1 OFF in that order.

#### **WARNING**

Failure to remove main source of AC Power may result in personal injury, and/or damage to the equipment.

9. Perform the preceding steps on all drives in the faulty drive's AC power string before continuing.

#### **WARNING**

Whenever removing or replacing the AC Power Distribution Assembly, AC Power and cables must be removed from the drive. Failure to remove AC power may result in personal injury and/or damage to the equipment.

10. Disconnect AC IN (J1), and AC OUT (J2) connectors from AC Power Distribution Assembly (A6A2). (See Figure 4-2-20-B.)

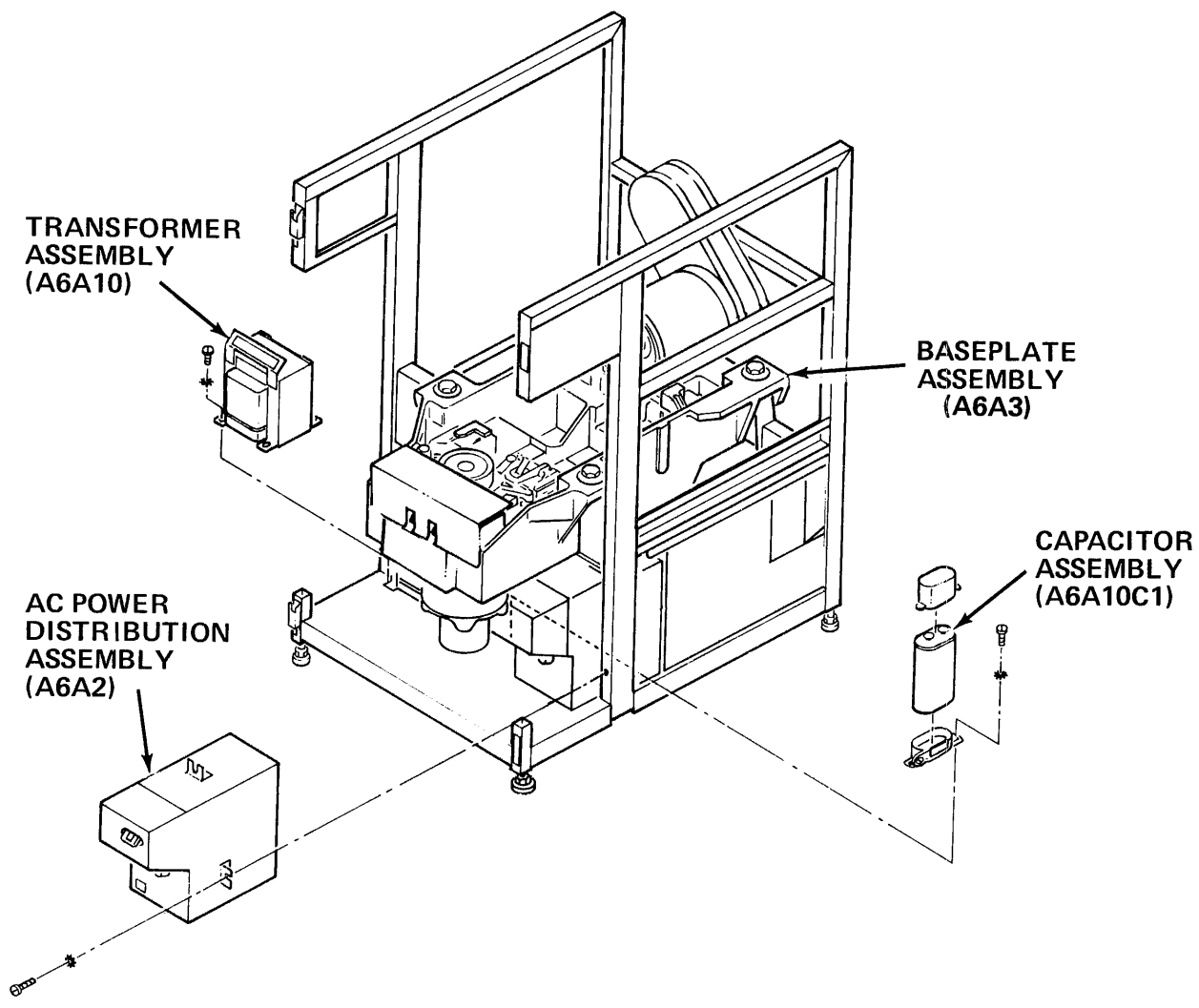

PB001623  
12-79

Figure 4-2-20-A AC Power Distribution Assembly

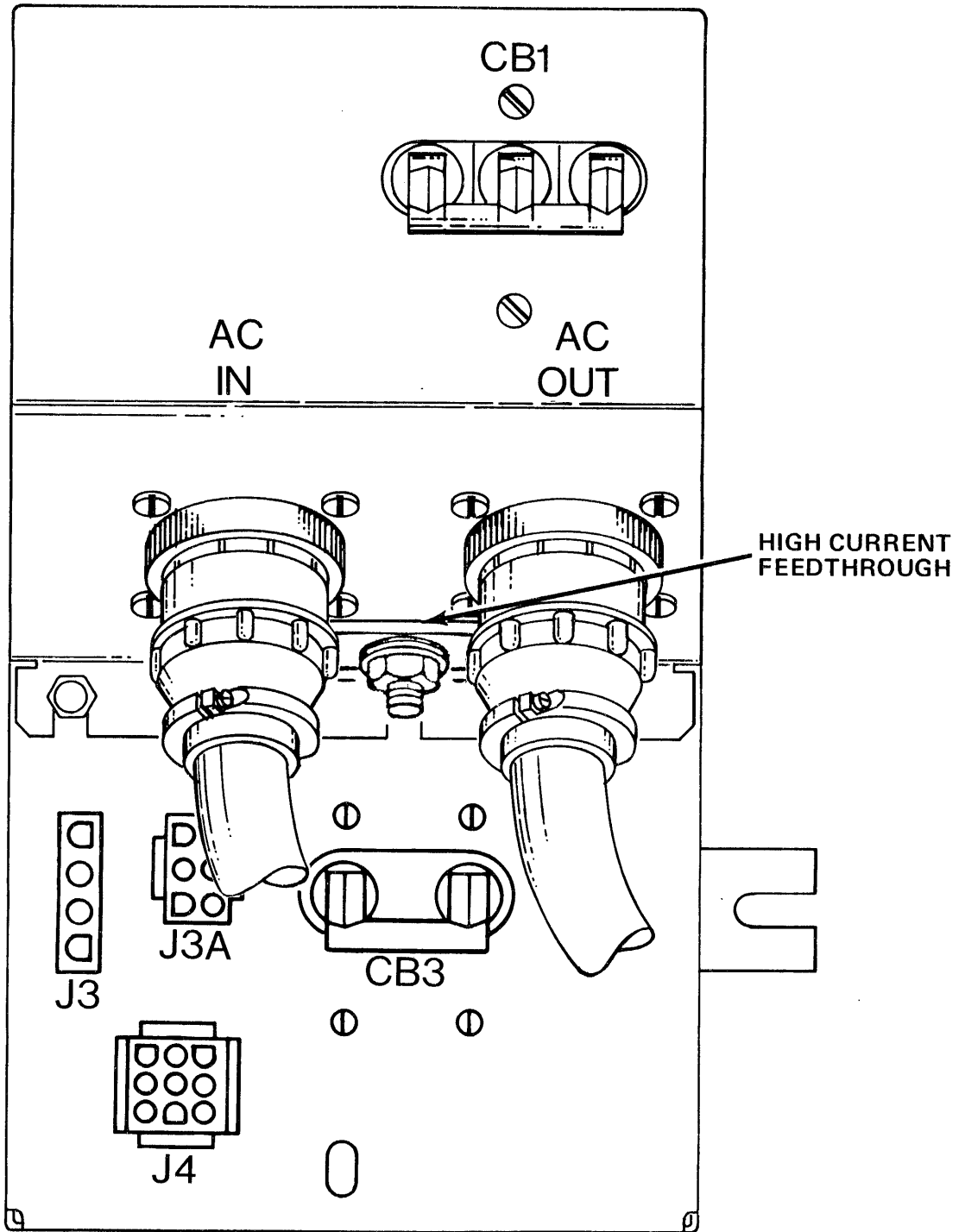

PB001314-2  
12/79

Figure 4-2-20-B AC Power Distribution Assembly (Front View)

11. Disconnect plug connectors from J3 and J4 located on the AC Power Distribution Assembly (A2). (See Figure 4-2-20-B.)

**NOTE**

J5 connector will be disconnected in Step 14.

12. Loosen and remove the top screw and lockwasher and only loosen the side screw that secure the AC Power Distribution Assembly to drive frame.
13. Slowly slide AC Power Distribution Assembly toward rear of drive to gain access to the J5 plug located on the left rear of the assembly.
14. Remove plug connector from J5 (AC Power Distribution Assembly). (See Figure 4-2-20-C.)
15. Slide AC Power Distribution Assembly out of drive frame.

Access can now be gained to the subassemblies contained in the AC Power Distribution Assembly. The following six procedures are for the removal and replacement of the subassemblies. Refer to Subsection 4.2.20.7 for the replacement procedure for the AC Power Distribution Assembly.

**4.2.20.1 Line Filter (A2FL1) (P/N 9800977-00)** - The following procedure describes the removal and replacement of the Line Filter from the AC Power Distribution Assembly (See Figure 4-2-20-C).

**WARNING**

The removal procedure for the AC Power Distribution Assembly (A2) **MUST BE COMPLETED** before performing this procedure. Failure to comply may result in personal injury and/or damage to the equipment.

This procedure requires the following tools:

- 5/16-inch Nutdriver
  - Screwdriver
  - 3/8-inch Nutdriver
1. Remove the side cover of the AC Power Distribution Assembly by removing the two (2) screws with the 5/16-inch nutdriver. Rotate the cover towards CBI and lift out and away from the assembly.
  2. Loosen and remove two (2) screws on top of the Circuit Breaker Bracket Assembly.
  3. Loosen (DO NOT REMOVE) two (2) screws in slots under the Circuit Breaker Bracket Assembly.

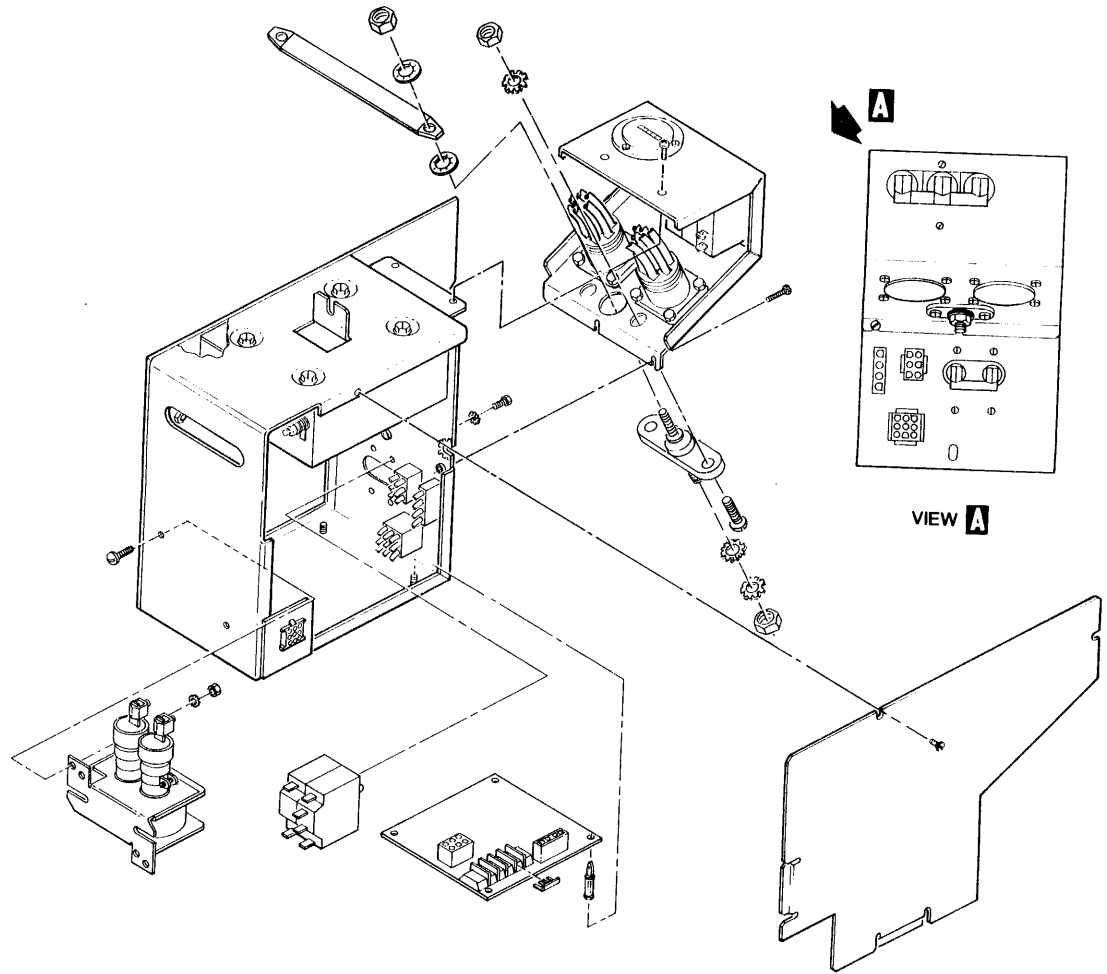

PC035671-1

Figure 4-2-20-C AC Power Distribution Assembly (Exploded View)

4. Lift the Circuit Breaker Bracket Assembly up and carefully let dangle.
5. Carefully label and, using the 3/8-inch nutdriver, remove the eight (8) wires attached to the LINE end of the line filter. This will free the circuit breaker bracket.
6. Carefully label and, using the 3/8-inch nutdriver, remove the five (5) wires attached to the LOAD end of the line filter.

**CAUTION**

Be careful NOT to drop the line filter when removing it from the AC Power Distribution Assembly or damage to the equipment may result.

7. Supporting the filter with one hand, loosen and remove the four (4) screws and washers that secure it to the assembly.
8. Carefully remove the line filter from the assembly.

**NOTE**

Be sure not to damage the line filter "Insulator" located on top of the filter as it will be used again on the replacement line filter. If it is damaged another insulator must be ordered.

Installing the Replacement Line Filter

1. Note the replacement line filter is labeled LOAD and LINE. Orient the line filter so that the line end is closest to the circuit breaker bracket cutout.
2. Place insulator on top of Replacement Line Filter. Align screw holes.
3. Slide the line filter into the AC Power Distribution Assembly and secure it in place with the four (4) screws and washers.
4. Reconnect the eight (8) wires from the circuit breaker bracket to the line filter (LINE end).

**NOTE**

Reference Chapter 2 of this manual when verifying terminal connections.

5. After verifying the correctness of the wiring, re-attach and secure the circuit breaker bracket with the four (4) screws.
6. At the LOAD end of the line filter reconnect the five (5) wires.

#### NOTE

Reference Chapter 2 of this manual when verifying terminal connections.

7. Verify correctness of wiring.
8. Slide the AC Power Distribution Unit side cover into place and secure with the two screws.

Refer to subsection 4.2.20.7 for the replacement procedure for the AC Power Distribution Assembly (A2).

**4.2.20.2 PCA Three Phase Sense Detector (P/N 9709082-00)** - The following procedure describes the removal and replacement of the Three Phase Sense Detector in the AC Power Distribution Assembly. (See Figure 4-2-20-C.)

#### WARNING

The removal procedure for the AC Power Distribution Assembly (A2) **MUST BE COMPLETED** before performing this procedure. Failure to comply may result in personal injury and/or damage to the equipment.

This procedure requires the following tools:

- 5/16-inch Nutdriver
- Screwdriver

#### To remove the PCA:

1. Remove the side cover of the AC Power Distribution Assembly by removing the two (2) screws using a 5/16-inch nutdriver. Rotate the cover towards CB1 and lift out and away from the assembly.
2. Disconnect the P7/J7 connector plug.
3. Disconnect the P6/J6 connector plug.
4. Label the two wires attached to the terminal block TB1. Remove the two wires.
5. Remove the PCA from the AC Power Distribution Assembly by releasing it from the four retaining posts.

#### Installing the Replacement PCA:

1. Connect the two previously labeled wires to the terminal block TB1, terminals 1 and 4, on the replacement PCA.



2. Slide the PCA into the AC Power Distribution Assembly.
3. Align the PCA over the four posts and push down until the PCA locks into place.
4. Reconnect the P6/J6 and P7/J7 connectors.
5. Verify that the twisted pair of black wires is inserted in the slot between the CB1 bracket and the AC Power Distribution Assembly.
6. Replace the AC Power Distribution Assembly side cover and secure it with the two (2) screws.

Refer to Subsection 4.2.20.7 for the AC Power Distribution replacement procedure.

**4.2.20.3 Circuit Breaker (CB3) (P/N 9800976-00)** - The following procedure describes the removal and replacement of the CB3 in the AC Power Distribution Assembly. (See Figure 4-2-20C.)

**WARNING**

The removal procedures for the AC Power Distribution (A2) Assembly **MUST BE COMPLETED** before performing this procedure. Failure to comply may result in personal injury and/or damage to the equipment.

To remove CB3:

1. Remove the side cover of the AC Power Distribution Assembly by removing the two screws using a 5/16-inch nutdriver. Rotate the cover towards CB1 and lift out and away from the assembly.
2. Observe there are four wires attached to one side of CB3 and two wires to the other side.
3. Label the six wires attached to CB3. Remove the six wires.
4. At the front of the AC Power Distribution Assembly, remove the four screws and lockwashers securing CB3 to the AC Power Distribution Assembly.
5. Remove CB3.

To replace CB3:

1. Insert the replacement CB3 and secure it to the AC Power Distribution Assembly with the four screws and lockwashers.
2. Reconnect the six wires to CB3.

3. Replace the AC Power Distribution Assembly side cover and secure it with the two (2) screws.

Refer to Subsection 4.2.20.7 for the AC Power Distribution Assembly replacement procedure.

**4.2.20.4 Solenoid Mercury Relay (A2K1) (P/N 9800974-00)** - The following procedure describes the removal and replacement of Solenoid Mercury Relay in the AC Power Distribution Assembly (see Figure 4-2-20-C).

#### **WARNING**

The removal procedure for the AC Power Distribution Assembly (A2) **MUST BE COMPLETED** before performing this procedure. Failure to comply may result in personal injury and/or damage to the equipment.

This procedure requires the following tool:

- Offset screwdriver
- Screwdriver

#### Removing the Relay:

1. Remove the side cover of the AC Power Distribution Assembly by removing the two (2) screws using a 5/16-inch nutdriver. Rotate the cover towards CBI and lift out and away from the assembly.
2. Carefully label and tape together the pair of wires in each of two terminals on top of the relay.
3. Loosen (DO NOT REMOVE) the screw in each terminal and remove the wires.
4. Carefully label the two (2) wires connected to the side of the relay. Using an offset screwdriver, loosen (DO NOT REMOVE) the two (2) screws securing the wires. Remove the wires.
5. Through the cut out on the bottom of the AC Power Distribution Assembly, label the two (2) wires connected to the relay.
6. Loosen (DO NOT REMOVE) the screw in each terminal and remove the wires.
7. Remove the bolt, washer and nut (1 of 2) securing the relay to the AC Power Distribution Assembly.
8. From the side remove the bolt, washer and nut (2 of 2) securing the relay to the AC Power Distribution Assembly.
9. Remove the relay.

#### **NOTE**

When the mercury relay in the AC Power Distribution Assembly (A6A2) is replaced, securely package the defective device and return it to Digital Equipment Corp. for disposal. The return address is:

Digital Equipment Corporation  
PMR Warehouse  
111 Powder Mill Road  
Maynard, Massachusetts 01754

#### **Installing the Replacement Relay:**

1. Orient the relay correctly and secure in place with the two (2) bolts, washers and nuts.
2. From the side reconnect the four (4) wires in the two top terminals of the relay. Secure them in place by tightening the screws.
3. From the bottom cutout reconnect the two wires to the side terminals and the two wires to the bottom terminals of the relay. Secure them in place.
4. Replace the AC Power Distribution Assembly side cover and secure it with the two (2) screws.

**4.2.20.5 Circuit Breaker (CB1) (P/N 9800975-00)** - The following procedure describes the removal and replacement of the CB1 from the AC Power Distribution Assembly (A2). (See Figure 4-2-20-C.)

#### **WARNING**

The removal procedure for the AC Power Distribution Assembly (A2) **MUST BE COMPLETED** before performing this procedure. Failure to comply may result in personal injury and/or damage to the equipment.

This procedure requires the following tool:

- 5/16-inch Nutdriver
- Screwdriver

#### **Removing Circuit Breaker CB1:**

1. Remove the side cover of the AC Power Distribution Assembly by removing the two (2) screws using a 5/16-inch nutdriver. Rotate the cover towards CB1 and lift out and away from the assembly.
2. Loosen and remove two (2) screws on top of Circuit Breaker Bracket Assembly.

3. Loosen (DO NOT REMOVE) two (2) screws from top and side of Circuit Breaker Bracket Assembly.
4. Lift Circuit Breaker Bracket Assembly up and carefully let dangle.
5. Loosen and remove the two (2) screws and washers that secure CB1 to the bracket. Pull CB1 to the side to expose the terminals.
6. Carefully label the nine (9) wires attached to CB1.
7. Remove the wires from CB1. Remove CB1.

#### Installing the Replacement Circuit Breaker

1. Reconnect the nine (9) wires to the replacement circuit breaker. Verify connections made are correct.
2. Secure the circuit breaker to the bracket with the two (2) screws and washers previously removed.
3. Reattach and secure the circuit breaker bracket to the AC Power Distribution Assembly with the four (4) screws.
4. Replace the AC Power Distribution Assembly side cover and secure it with the two (2) screws.

Refer to Subsection 4.2.20.7 for the replacement procedure for the AC Power Distribution Assembly (A2).

**4.2.20.6 Time Meter Assembly (A2TT1) (P/N 9035544-00, 60 Hz; -01, 50 Hz)** - The following procedure describes the removal and replacement of Time Meter Assembly from the AC Power Distribution Assembly (A2). (See Figure 4-2-20-C.)

#### **WARNING**

The removal procedure for the AC Power Distribution Assembly (A2) **MUST BE COMPLETED** before performing this procedure. Failure to comply may result in personal injury and/or damage to the equipment.

This procedure requires the following tool:

- 1/4-inch Nutdriver
  - Screwdriver
1. Remove the side cover of the AC Power Distribution Assembly by removing the two (2) screws using a 5/16-inch nutdriver. Rotate the cover towards CB1 and lift out and away from the assembly.

2. Loosen and remove two (2) screws on top of Circuit Breaker Bracket Assembly.
3. Loosen (DO NOT REMOVE) two (2) screws in slots under the Circuit Breaker Bracket Assembly.
4. Lift Circuit Breaker Bracket Assembly up and carefully let dangle.
5. Loosen (DO NOT REMOVE) the two (2) screws and remove the two (2) time meter leads from the three phase sense detector PCA terminal block TB1 pins 1 and 4.
6. Loosen and remove the two (2) screws and washers that secure CBI to the bracket. Pull CBI to the side to expose bolts on the time meter.
7. Loosen and remove the three (3) bolts, washers and nuts holding the time meter to the bracket. Remove the time meter.

#### Installing the Replacement Time Meter:

1. Verify replacement time meter is the correct frequency (50 Hz or 60 Hz).
2. Feed the time meter leads through the cutout on the circuit breaker bracket. Orient the time meter correctly.
3. Secure the time meter to the circuit breaker bracket with the three (3) bolts, washers and nuts.
4. Connect the two time meter leads to terminals on the phase detector PCA terminal block (TB1).
  - 60 Hz (all voltages) and 50 Hz Delta (230 VAC) - Terminals 1 and 4 with jumper bridging Terminals 3 and 4.
  - 50 Hz Wye (380 VAC) - Terminals 1 and 2 with the jumper bridging Terminals 2 and 3.
5. Reinstall CBI and secure it in place with the two (2) screws and washers.
6. Attach the circuit breaker bracket to the AC Power Distribution Assembly with the four (4) screws.
7. Place the time meter leads into the cutout between the circuit breaker bracket and the AC Power Distribution Assembly.
8. Replace the AC Power Distribution Assembly side cover and secure it with the two (2) screws.

Refer to Subsection 4.2.20.7 for the replacement procedure for the AC Power Distribution Assembly (A2).

#### 4.2.20.7 AC Power Distribution Assembly (A6A2) Replacement

1. Slide the AC Power Distribution Assembly halfway into the frame.
2. Connect the P5 plug to the J5 receptacle on the left side of the A2 assembly.
3. Slide the AC Power Distribution Assembly the rest of the way into the frame.
4. Secure the AC Power Distribution Assembly to the frame with the two screws and lockwashers.
5. Connect the P3 and P4 plugs to the J3 and J4 receptacles respectively.
6. Verify CB3 and CB1 are OFF.
7. Reconnect the AC cable to AC IN (J1) and, if applicable, AC OUT (J2). Attach AC ground strap.
8. Set CB1, CB2 and CB3 ON in that order.
9. Close the top cover and drive rear door.
10. Set the SERVICE switch ON.
11. Set the MASSBUS ENABLE/DISABLE switch to ENABLE.
12. Replace electronics library cover.
13. Close the drive front door.
14. Place the START/STOP switch in the START position.
15. Perform "Power On Start" procedure.
16. Resume customer operations.

Repeat Steps 8-16 for all other drives in AC power string.

#### 4.2.21 Resonant Capacitor (A6A10C1) (P/N 3013826-11

The following procedure describes the removal and replacement of the Resonant Capacitor (See Figure 4-2-21-A).

#### **WARNING**

Whenever removing or replacing the Resonant Capacitor, AC power and cables must be removed from the drive. Failure to remove AC power may result in personal injury and/or damage to the equipment.

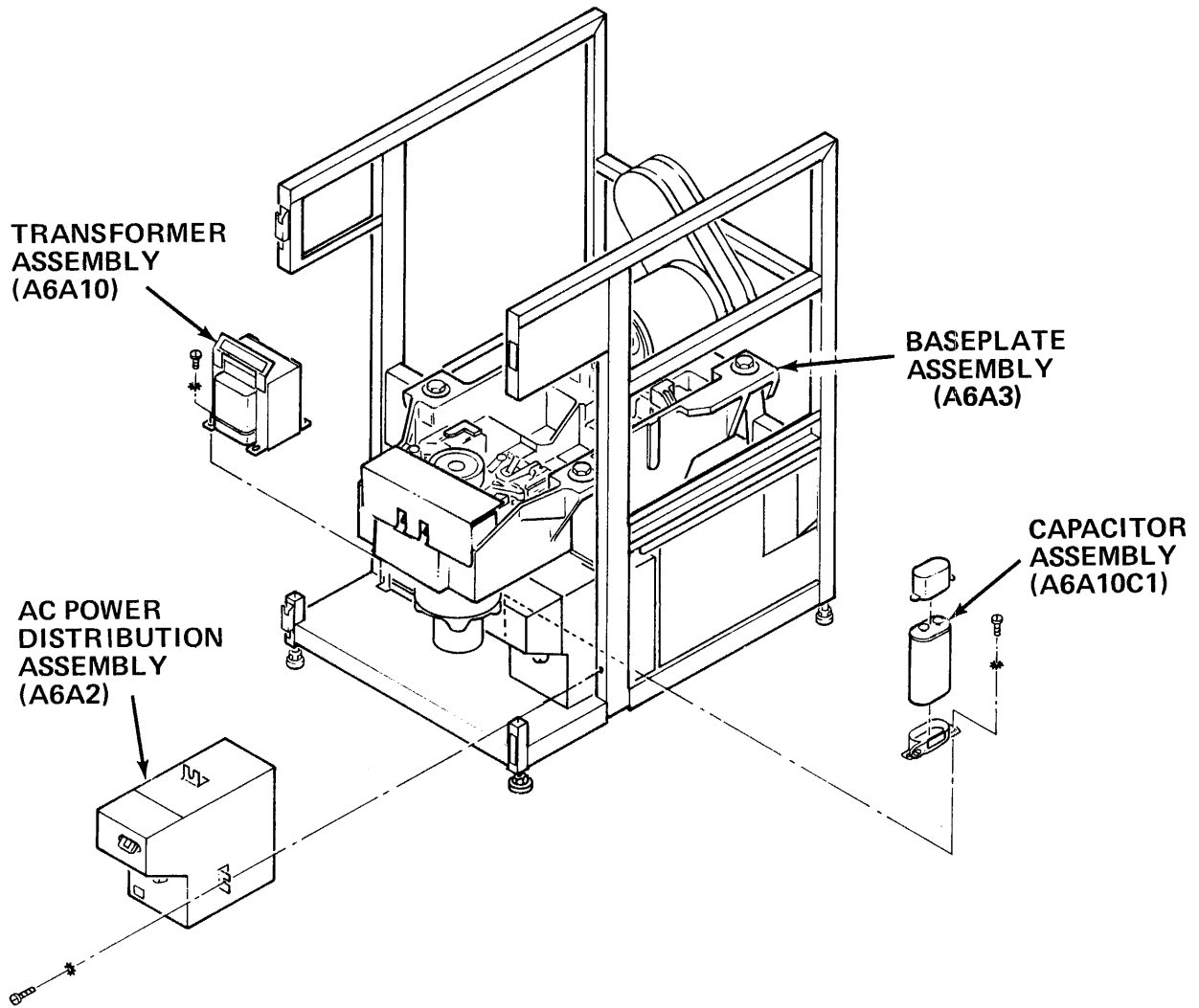

PB001623  
12-79

Figure 4-2-21-A Resonant Capacitor

This procedure requires the following tool:

- Plastic handle screwdriver
  - 5/16-inch nutdriver
1. Obtain permission to disrupt customer operations. Place drive ONLINE/OFFLINE switch to OFFLINE.
  2. Place START/STOP switch in the STOP position.
  3. Open the drive front door.
  4. Loosen (DO NOT REMOVE) two (2) screws located in the keyhole slots that secure the electronics library cover to the library cage. Lift the cover up and away from the drive.
  5. Set the MASSBUS ENABLE/DISABLE switch to DISABLE (down).
  6. Set the SERVICE switch OFF.
  7. At the rear of the drive, raise top cover to its detent position. Open the drive rear door.
  8. Set CB3, CB2 and CB1 OFF in that order.
  9. Perform the preceding steps on all drives in the faulty drive's AC power string before continuing.

**WARNING**

Failure to remove main source of AC Power may result in personal injury, and/or damage to the equipment.

10. Disconnect the AC IN (J1) and AC OUT (J2) connectors from AC Power Distribution Assembly (A6A2) (see Figure 4-2-21-B).

**WARNING**

Wait for approximately fifteen seconds (allowing the capacitor to drain) before touching the Resonant Capacitor or personal injury may result.

11. Carefully slide the insulating boot from the top of the Resonant Capacitor, exposing the capacitor terminals. (DO NOT touch the capacitor terminals when removing the boot.



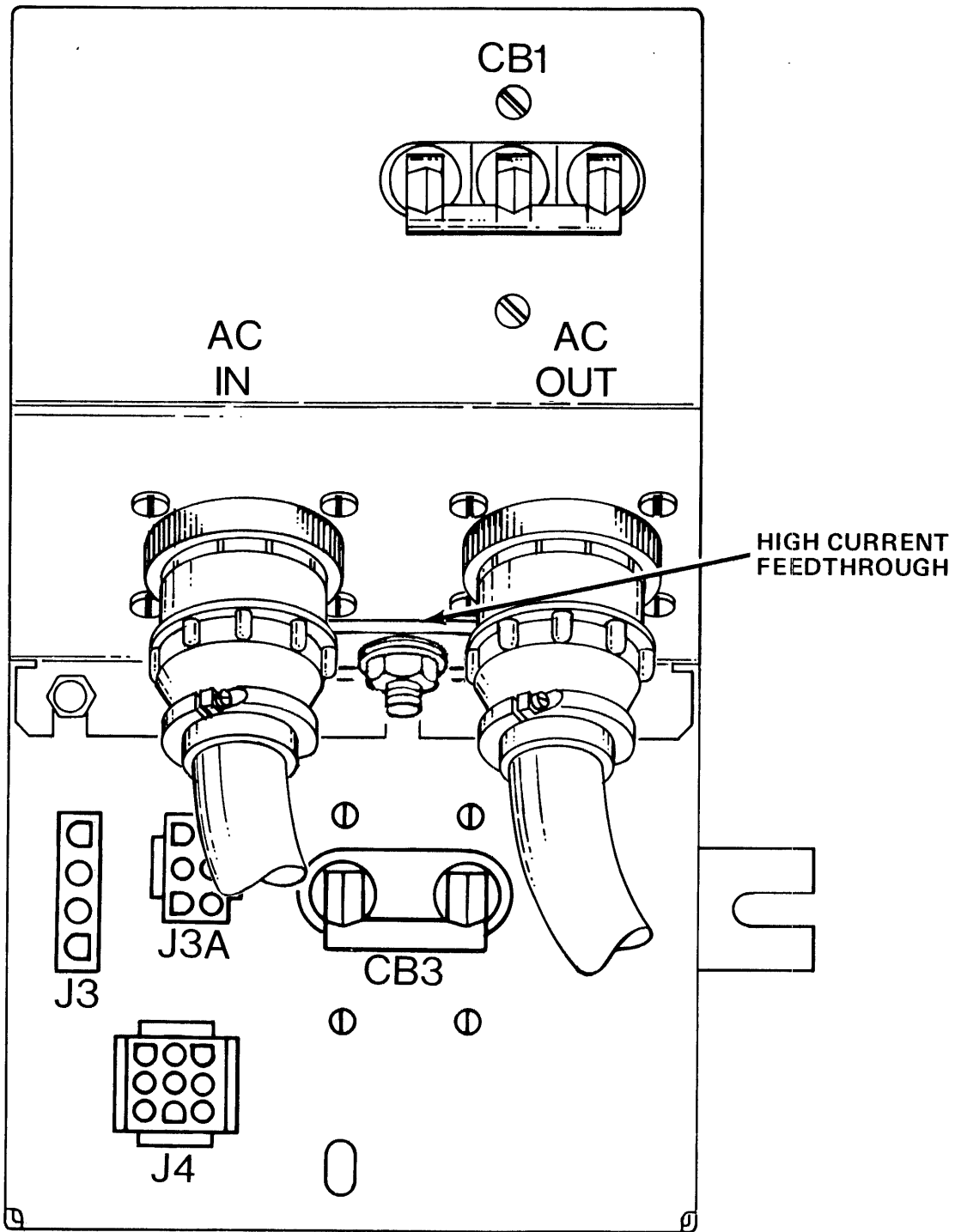

PB001314-2  
12/79

Figure 4-2-21-B AC Power Distribution Assembly (Front View)

### **WARNING**

Failure to "short" this capacitor before removing it from the drive may result in personal injury.

### **NOTE**

Step 12 pertains to shorting out Resonant Capacitor before removing it from the drive.

12. Using an insulated screwdriver, short across capacitor terminals with the end of the insulated screwdriver blade for approximately five seconds.
13. Remove two (2) slip on red leads from top of capacitor.
14. Loosen (DO NOT REMOVE) screw on capacitor mounting bracket. (DO NOT REMOVE bracket).
15. Remove Resonant Capacitor from drive.

#### Installing Replacement Resonant Capacitor:

1. Place capacitor in capacitor mounting bracket and tighten screw.
2. Install the two (2) clip-on red leads to the terminals on top of the capacitor. Polarity of the leads does not have to be observed.
3. Slide the insulating boot down over the capacitor terminals.
4. Reconnect AC power cables to AC IN (J1) and to AC OUT (J2) if applicable.
5. Set CB1, CB2 and CB3 ON in that order.
6. Set the SERVICE switch ON. Set the MASSBUS ENABLE/DISABLE switch to ENABLE.
7. Replace the electronics library cover, and tighten the two (2) screws in the keyhole slots. Close all drive covers and doors.
8. Place START/STOP switch in STOP position.
9. Perform "Power On Start" procedures on all drives in AC Power String.

#### **4.2.22 Transformer Assembly (A6A10) (P/N 9800900-00, 60 Hz; 9800899-00, 50 Hz)**

The following procedure describes the removal and replacement of the Transformer Assembly. (See Figure 4-2-21-A.)

### **WARNING**

Whenever removing or replacing the Transformer Assembly, AC power and cables must be removed from the drive. Failure to remove AC power may result in personal injury and/or damage to the equipment.

This procedure requires the following tools:

- Screwdriver
  - Long handled screwdriver or 5/16-inch nutdriver
  - Cable ties (12)
  - Cutters
1. Obtain permission to disrupt customer operations. Place drive ONLINE/OFF-LINE switch to OFFLINE.
  2. Place START/STOP switch in the STOP position.
  3. Open drive front door.
  4. Remove the electronics library cover by loosening (DO NOT REMOVE) two (2) screws in the keyhole slots. Lift the library cover up and away from drive.
  5. Set the MASSBUS ENABLE/DISABLE switch to DISABLE (down).
  6. Set the SERVICE switch OFF.
  7. At the rear of drive, raise top cover to its detent position. Open drive rear door.
  8. Set CB3, CB2 and CB1 OFF in that order.
  9. Perform the preceding steps on all the drives in the faulty drive's AC power string before continuing.

### **WARNING**

Failure to remove main source of AC Power may result in personal injury and/or damage to the equipment.

10. Disconnect AC IN (J1) and AC OUT (J2) connectors from AC Power Distribution Assembly (A6A2) (see Figure 4-2-21-B).
11. Unbolt faulty drive from the string, raise the leveling pads putting the drive weight back onto the casters. Roll the drive out from the string.

- Carefully slide insulating boot from the top of the Resonant Capacitor exposing the capacitor terminals. (DO NOT touch capacitor terminals when removing boot.)

**WARNING**

Failure to "short out" capacitor before removing leads (Step 15) may result in personal injury.

**NOTE**

Step 13 pertains to shorting out the capacitor before removing the capacitor leads.

- Using an insulated screwdriver, short across capacitor terminals with end of insulated screwdriver blade for approximately five (5) seconds.
- Remove two (2) slip on red leads from top of capacitor.
- Label and remove all wires connected to transformer terminal board (A6A10TB1).
- Cut the three (3) cable ties that secure transformer wires to drive frame.
- Cut the two (2) cable ties that secure clear plastic air hose (tubing) to transformer wires.
- Cut the seven (7) cable ties that secure the harness together.
- Loosen and remove the cable clamp at the lower right corner of the electronics library to free the cable harness.
- At the front of the drive, unplug harness plug connectors from J1 and J3 of Rectifier Assembly PCA, A1A1. Thread the unplugged harness down through the corner of the library cage.
- At the rear of the drive, using a 5/16-inch nutdriver loosen and remove two (2) screws and lockwashers from transformer mounting feet (at terminal board side of transformer).
- Using a long handled screwdriver or 5/16-inch nutdriver, reach over cable tray and down to the other side of transformer. Loosen (DO NOT REMOVE) two (2) remaining screws.
- Slide Transformer Assembly out of drive frame, threading connecting harness down through the drive until it is completely free from the drive.

Installing the Replacement Power Transformer:

- Slide the transformer onto the frame and secure it in place by tightening the two rear bolts, and installing and tightening the two front bolts.

2. Thread the transformer harness along the drive frame and secure it in place with panduits.

**NOTE**

Be sure to secure the harnesses to the drive frame in the three designated places. Also be sure to secure the air hose to the harness in two places. The remaining seven panduits should be spaced out along the length of the harnesses.

3. Connect the two wires, previously marked, to the power transformer terminal board (A6A10TB1). Verify the correctness of the connections.
4. At the front of the drive, plug in harness connectors J1 and J3 of the Rectifier Assembly PCA (A1A1).
5. Thread the harness through the corner of the library cage. Secure them in place with the cable clamp.
6. Install the two (2) clip-on red leads to the two terminals on the top of the resonant capacitor. Polarity of the leads does not have to be observed.
7. Slide the insulating boot down over the capacitor terminals.
8. Roll the drive back into place. Lower the leveling pads and align the bolt holes in the frame. Bolt the drive frames together.
9. Reconnect the AC power cables to AC IN (J1) and to AC OUT (J2) if applicable.
10. Set CB1, CB2 and CB3 ON in that order.
11. Set the SERVICE switch ON. Set the MASSBUS ENABLE/DISABLE switch to ENABLE.
12. Replace the electronics library cover, and tighten the two (2) screws in the keyhole slots. Close all drive service covers and doors.
13. Place START/STOP switch in STOP position.
14. Perform "Power On Start" procedures on all drives in AC Power String. Resume customer operations.

### **4.3 ADJUSTMENTS**

None are required.

## CHAPTER 5

### PREVENTIVE MAINTENANCE

#### 5.1 INTRODUCTION

This chapter covers preventive maintenance for the RP07 Disk Drive.

#### 5.2 TOOLS AND MATERIALS REQUIRED FOR PREVENTIVE MAINTENANCE

It is recommended that the following tools and materials be available to the Field Engineer before going to the customer site (drive location) to perform Preventive Maintenance.

- Prefilter
- Absolute Filter
- \*Air Pressure Gauge and Adapter Hose
- Plastic Bag (small sandwich type)
- Regular Screwdriver

\*Optionally required.

#### 5.3 PREVENTIVE MAINTENANCE SCHEDULE

Successful preventive maintenance requires the performance of systematic inspections and maintenance programs.

Table 5-3 identifies the minimum required maintenance and specifies the frequency with which it should be performed.

Although the maintenance philosophy is designed for the product-trained Field Engineer (FE), it is recognized that there are differences in levels of skill and experience among FEs. To aid the FE in performing PM, see Preventive Maintenance Procedures (subsection 5.4 of this manual). Preventive maintenance procedures provide the FE with detailed explanations pertaining to the preventive maintenance philosophy.

Table 5-3 Preventive Maintenance Schedule

ITEM	SEMI-ANNUAL	ANNUAL	ESTIMATED TIME	PM PROCEDURES
Before and after Scheduled Maintenance	X	X	.3 hour or less	Perform "Power On Start" and insure no error codes appear
Prefilter	X	X	.1 hour	5.4.1
Backpanel	X	X	.1 hour or less	5.4.2
Cables and Harnesses	X	X	.1 hour or less	5.4.3
Air Hoses	X	X	.1 hour or less	5.4.4
Component, Assembly, Subassembly Attaching Hardware	X	X	.1 hour or less	5.4.5
Absolute Filter		X	.4 hour	5.4.6
Battery Pack	X		.2 hour	5.4.7

#### 5.4 PREVENTIVE MAINTENANCE PROCEDURES

##### NOTE

Whenever a drive(s) is to be taken off the system (for Field Engineer (FE) inspection and/or repair) and before returning the drive to customer operations, perform "Power On Start" procedure to validate overall drive operation.

##### 5.4.1 Prefilter (See Figure 5-4-1)

The Prefilter (a fiber-type filter) traps the larger airborne particle contaminants, preventing them from circulating through the Electronics Library (A1) and the Absolute Filter (A5A1).

The Prefilter should be replaced semi-annually by maintenance personnel. It should also be checked by the FE during each service call and replaced if it becomes dirty and limits airflow. (See Prefilter Replacement, Subsection 5.4.1.1 of this manual.)

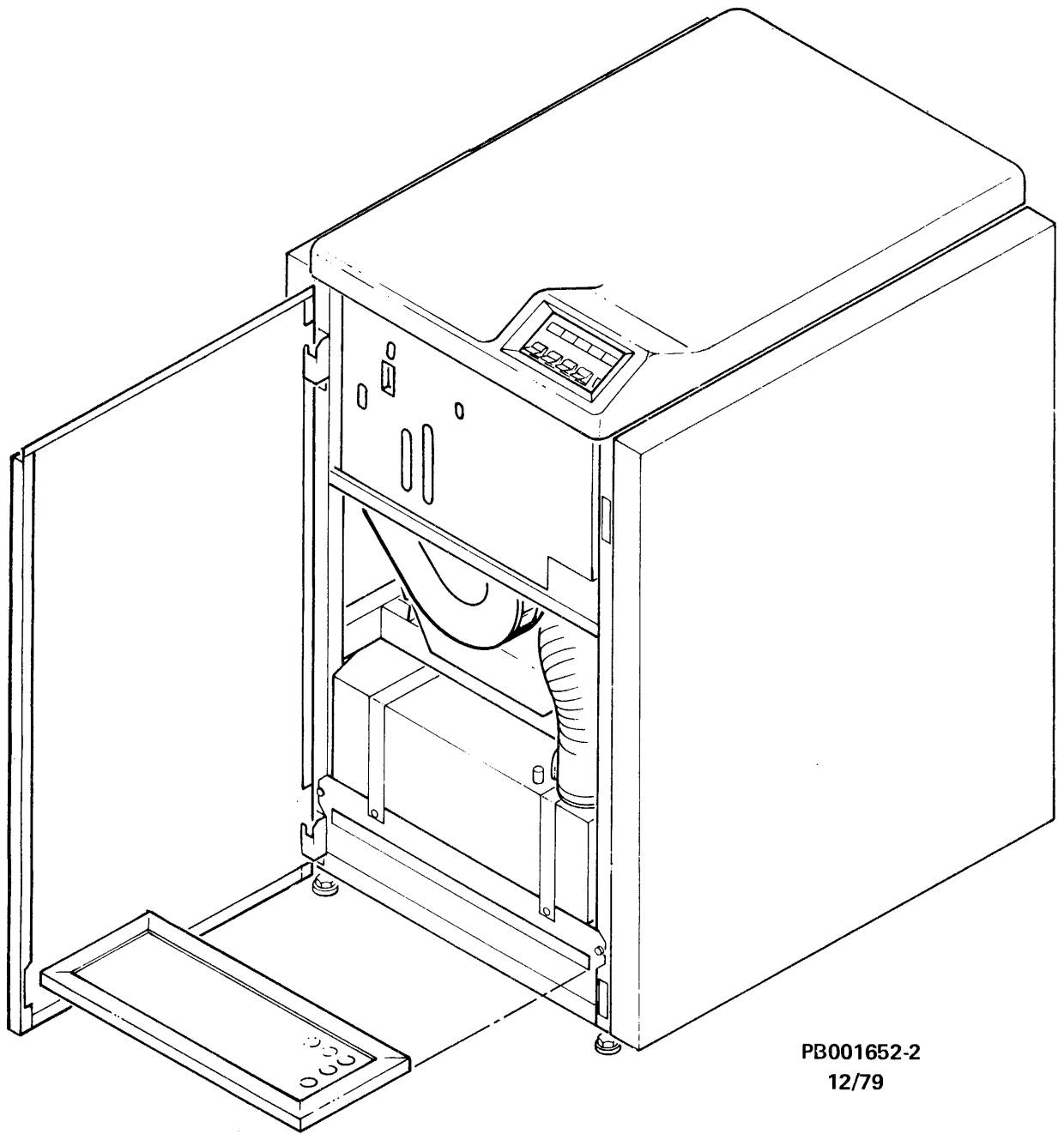

PB001652-2  
12/79

Figure 5-4-1 Drive Prefilter



**NOTE**

The Prefilter can be checked without disrupting customer operations. If a replacement Prefilter is required and not available, it is left to the discretion of the FE whether to disrupt customer operations (placing the drive OFFLINE) until a replacement filter becomes available or to replace the existing filter.

Check the Prefilter (see Figure 5-4-1) by opening the drive front cover and sliding the prefilter out of its housing in the Blower Assembly (A5). Visually inspect the bottom of the Prefilter for dirt and dust accumulation.

**CAUTION**

Do NOT attempt to clean and reuse the Prefilter or damage to the equipment may result. The Prefilter is a throw-away item and must be discarded after use.

If a replacement filter is not required, slide the Prefilter back into its housing in the Blower Assembly, and close the drive front cover.

**NOTE**

Check airflow arrow direction to insure correct filter replacement. The (filter) airflow arrow should point up toward the top of the drive. Placing the Prefilter upside down could result in accumulated dirt and/or dust particles discharging up into the drive.

**5.4.1.1 Prefilter Replacement - Refer to Figure 5-4-1.**

1. Open drive front cover.
2. Slide existing Prefilter out of its housing in the Blower Assembly. Discard it.

**NOTE**

Handle replacement Prefilter with care. Do NOT use a replacement Prefilter that is bent, broken or obviously damaged.

3. Slide replacement Prefilter into its housing in the Blower Assembly. Note airflow arrow direction.

#### **NOTE**

The airflow arrow should point up toward the top of the drive; Pre-filter should slide all the way into its housing.

4. Close drive front cover.

#### **5.4.2 Backpanel**

#### **CAUTION**

Indiscriminate probing (with tools and/or test equipment) of the Electronics Library backpanel may cause damage to pins, wires and/or connectors. If the "Power On Start" procedure has been completed without cause for further investigation, do not perform PM on the backpanel other than the following visual inspection.

1. Open drive top cover to its detent position
2. Open drive rear cover
3. Visually inspect the Electronics Library backpanel for the following:

#### **CAUTION**

Do NOT disconnect ribbon cable connector plugs from the backpanel to check their condition unless specified to do so. Indiscriminately disconnecting and reconnecting backpanel cables could be detrimental. Damage to connector pins could result.

- Inspect for possible loose jumper leads. Secure and tighten when necessary.
- Inspect for possible broken or frayed wires. If this condition exists, remove AC power (see Safety, AC Power, Subsection 1.5.3.1 of this manual) and replace affected wires.
- Inspect air pressure switch (clear plastic) hose. Check its condition and seating. If hose is cracked or broken, replace. See Removal and Replacement Procedures, Subsection 4.2.12 of this manual.

### 5.4.3 Cables and Harnesses

#### CAUTION

Do NOT disconnect cables or harness connector plugs to check their condition unless requested to do so. Cable and harness connectors, jacks, plugs and terminals can be damaged by repeated disconnecting and connecting. Care should be used whenever installing, reconnecting and routing cables and harnesses. Reference Chapter 2 of this manual for cabling configuration when required.

Before installing or replacing a cable and/or harness:

1. Visually inspect the cable and its shield for possible cuts, tears or abrasions. Replace when necessary.
2. Visually inspect jacks, plugs, power connectors and terminals for possible loose, bent or broken pins or connectors. Replace when necessary.

#### NOTE

If corrosion is detected, all associated (mating) connectors must be examined.

3. Visually inspect for loose or broken cable ties and clamps. Replace or tighten when required.

If a cable and/or cable connector replacement is required, see Illustrated Parts Breakdown (ER-ORP07-IP). Drive internal cables are listed within the Major Assembly or Subassembly Index. For drive external cables see Index 2.1 of the Illustrated Parts Breakdown.

#### 5.4.4 Air Hoses (see Figure 5-3-4)

The RP07 drive contains two plastic air hoses which are part of the drive air circulation system. (For a detailed explanation of the RP07 drive air circulation system, see the Technical Description Manual ER-ORP07-TD).

The large plastic air hose is clamped to the Absolute Filter discharge opening and the HDA air nozzle. The (clear plastic) air hose tubing is attached to the Absolute Filter and the air pressure switch. (Air pressure switch is mounted to the Electronics Library backpanel.)

1. Visually inspect the large air hose for possible cracks or deterioration. If replacement is required, see Removal and Replacement Procedures, Subsection 4.2.12.2 of this manual.

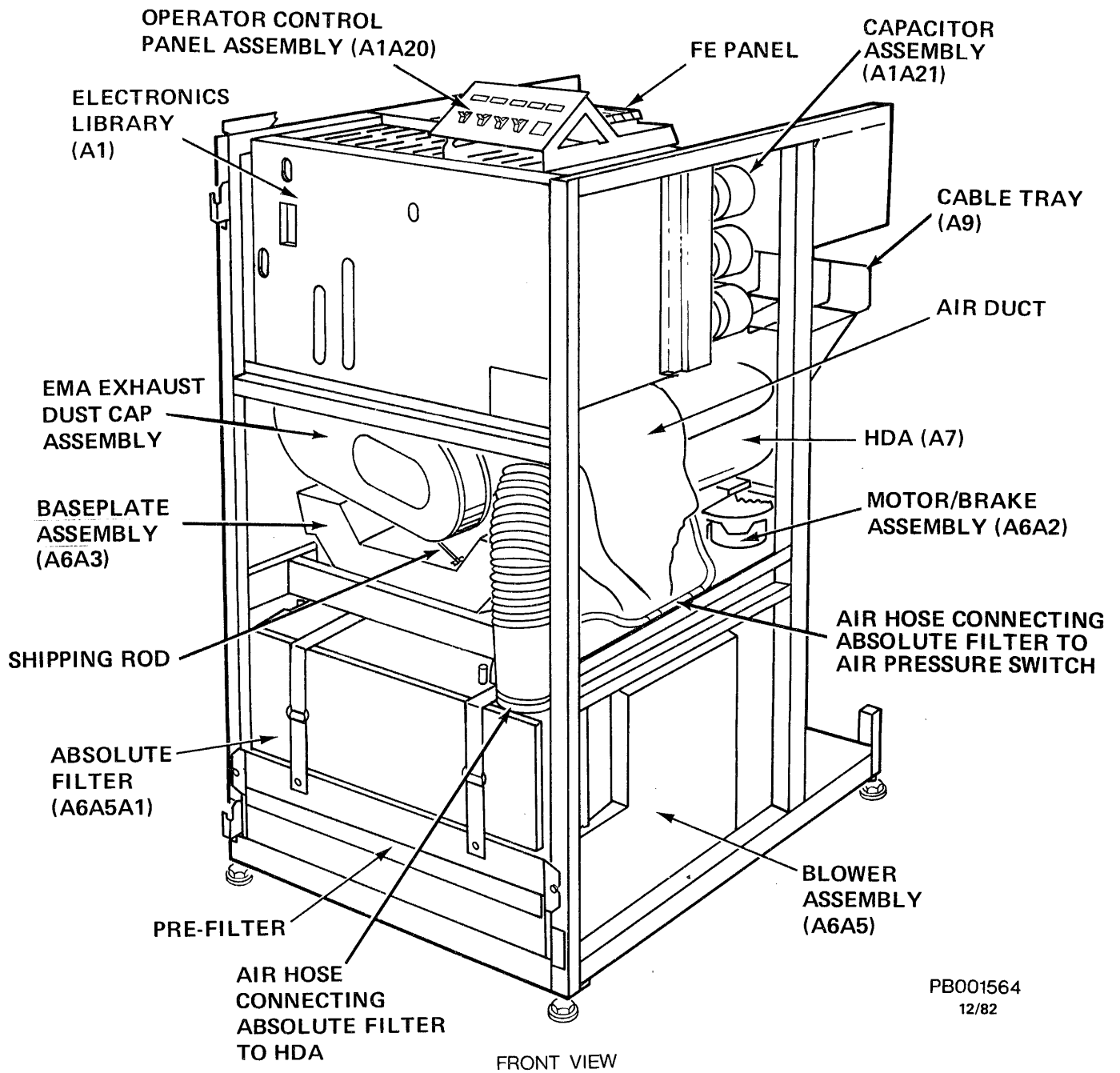

Figure 5-4-4 RP07 Front View

### **CAUTION**

Replacing the large air hose must be done with care to prevent contaminants from entering it and damaging the HDA. Follow the Removal and Replacement Procedure step by step and do not deviate from it.

2. Check the large air hose for seating. Insure that the hose is properly and securely clamped at both connections.
3. Visually check the (clear plastic) air hose tubing for seating and condition. Insure that the tubing is not pinched, damaged or loose. If replacement is required, See Removal and Replacement Procedures, Subsection 4.2.12.1 of this manual.

#### **5.4.5 Component, Assembly Subassembly Attaching Hardware**

Attaching hardware constitutes the parts or fasteners necessary to secure a component, assembly or subassembly to (or within) the drive.

Inspect the drive for possible cracked, broken or missing hardware. Replace as required. Reference the Illustrated Parts Breakdown (ER-0RP07-IP) when attaching hardware replacement is required. Check the attaching hardware during component, assembly or subassembly replacement for tightness and fitting. Tighten when necessary.

#### **5.4.6 Absolute Filter**

The Absolute Filter (see Figure 5-4-4) is a 0.3 micron filter that provides 99.97 percent filtering efficiency of the pressurized air entering the HDA (A7) and the EMA (A3A1) areas. The Absolute Filter may be checked and/or replaced annually.

The condition of the Absolute Filter is determined by checking the filter exhaust. See Absolute Filter Air Pressure Check, Subsection 5.4.6.1 of this manual. If replacement of the Absolute Filter is desired, see Absolute Filter Replacement, Subsection 5.4.6.2 of this manual.

**5.4.6.1 Absolute Filter Air Pressure Check** - Air pressure measurements should be taken after initial drive installation, after Absolute Filter replacement, and may be checked annually thereafter.

The following procedure provides the recommended method of taking air pressure measurements using the (optional) Air Pressure Gauge Assembly, and Air Pressure Gauge Adapter Hose.

1. Obtain permission to disrupt customer operations. Place the ONLINE/OFFLINE switch to OFFLINE.
2. Place START/STOP switch to STOP.
3. Open the drive front door.

4. Remove the electronics library cover by loosening (DO NOT REMOVE) the two screws in the keyhole slots. Lift the library cover up and away from the drive.
5. Set the MASSBUS ENABLE/DISABLE switch to DISABLE (down).
6. Set the SERVICE switch OFF (down).
7. At the rear of the drive, raise the top cover and open the drive rear door.
8. Set CB3, CB2 and CB1 OFF in that order.
9. With the START/STOP switch in STOP position, set CB1 ON (up).
10. Remove the air pressure cap from the outermost air pressure tap, located on top of the Absolute Filter. (See Figure 5-4-6-1.)
11. Attach the Air Pressure Gauge Adaptor Hose to the air pressure tap.

**NOTE**

Fitting end of Air Pressure Gauge Adapter Hose mates with Air Pressure Gauge Assembly.

12. Connect the Air Pressure Gauge Assembly.
13. Record exhaust pressure.
14. Refer to Table 5-4-6-1, Air Pressure Records. The exhaust pressure of the replacement Absolute Filter should be at least that shown in the Air Pressure Records. If the exhaust pressure matches the air pressure records on Table 5-4-6-1, go to step 7. If the exhaust pressure is less than shown, change the Prefilter (Subsection 5.4.1.1 of this manual).

**NOTE**

After Prefilter replacement, record exhaust pressure. If exhaust pressure records on Table 5-4-6-1, go to step 7. If the exhaust pressure is still less than shown, go to Air Flow Check, Subsection 5.4.6.3 of this manual.

15. Remove Air Pressure Gauge Assembly and Air Pressure Gauge Adapter Hose from the air pressure tap.
16. Replace the air pressure cap on the Absolute Filter air pressure tap.
17. Set CB2 and CB3 ON.
18. Set the SERVICE switch to ON. Set the MASSBUS ENABLE/DISABLE switch to ENABLE.

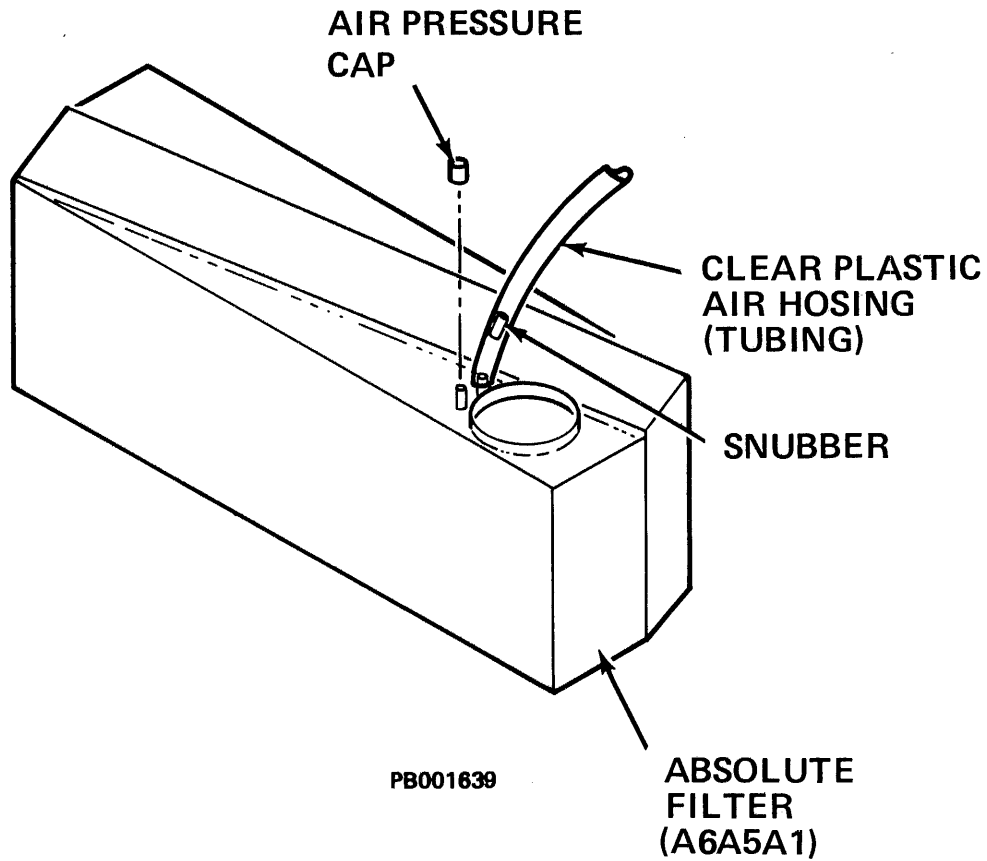

Figure 5-4-6-1 Absolute Filter

19. Replace the electronics library cover and tighten the two (2) screws in the keyhole slots.
20. Close all drive covers.
21. Place START/STOP switch in the START position.
22. Place the ONLINE/OFFLINE switch to ONLINE.
23. Resume customer operations.

Table 5-4-6-1 Air Pressure Records

INSTALLATION ALTITUDE		MINIMUM BLOWER PRESSURE AT INSTALLATION INCHES/H <sub>2</sub> O	REPLACE FILTER BEFORE PRESSURE RECORDS INCHES/H <sub>2</sub> O
(FEET)	(METERS)		
0	0	2.50	2.10
1000	305	2.42	2.03
2000	610	2.35	1.97
3000	914	2.28	1.90
4000	1219	2.21	1.84
5000	1524	2.14	1.78
6000	1829	2.07	1.71
7000	2134	2.01	1.66
8000	2438	1.94	1.61
9000	2743	1.88	1.55
10000	3048	1.82	1.50

**5.4.6.2 Absolute Filter Replacement** - See Figure 5-4-6-2.

This procedure requires the following tools:

- Regular screwdriver
- Plastic bag (small sandwich type)

**CAUTION**

DO NOT attempt to clean and reuse the Absolute Filter. It is a throw-away item and must be discarded after use. Damage to the HDA, heads or stack could result.

To remove the Absolute Filter:

**NOTE**

Before removing the Absolute Filter, be sure to have a replacement filter ready for immediate installation.



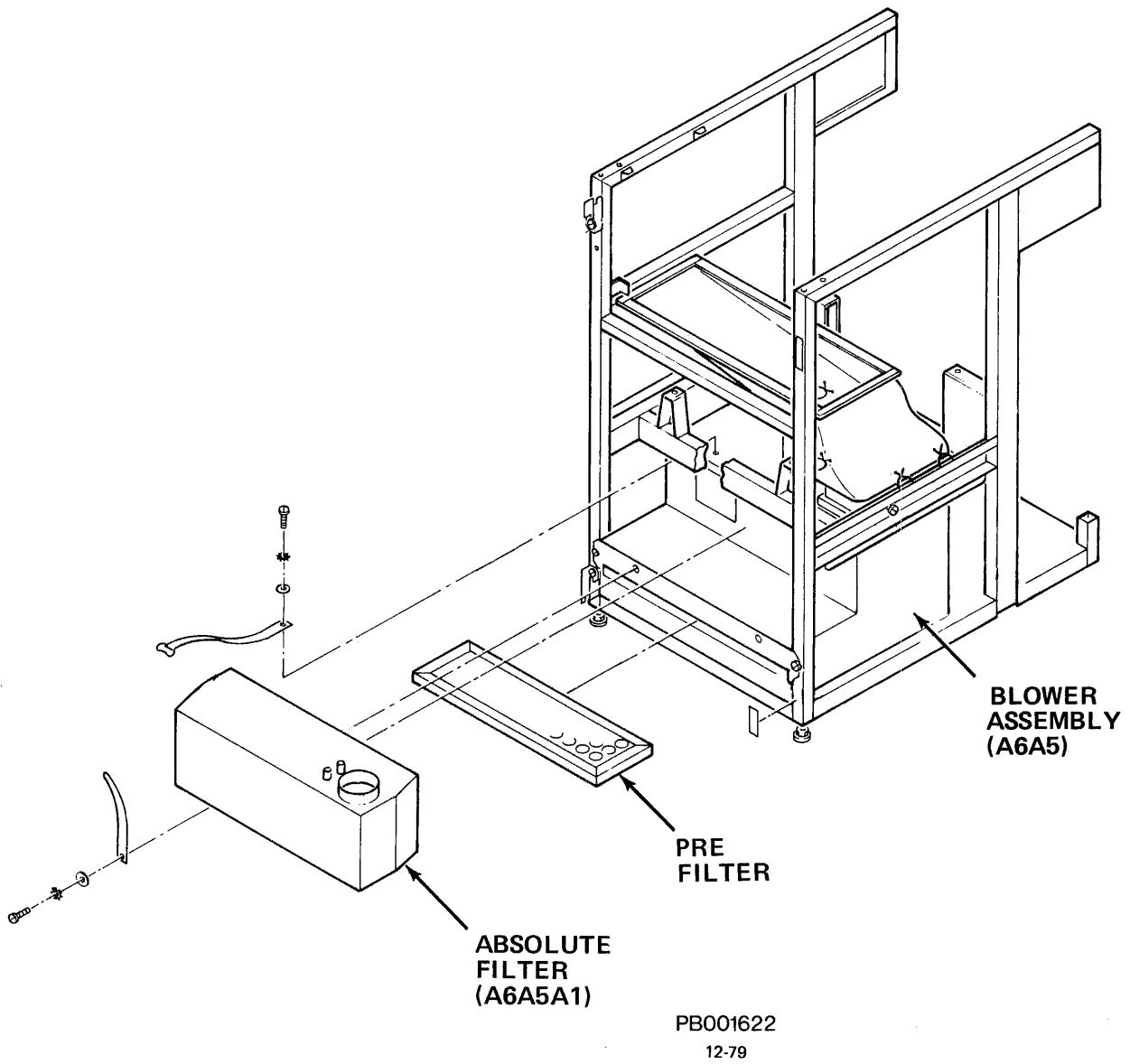

Figure 5-4-6-2 Absolute Filter Replacement

### **CAUTION**

To protect the replacement Absolute Filter from environmental contamination, DO NOT remove the filter from its protective (sealed) plastic bag, and DO NOT remove the protective sealing caps from the filter until requested to do so in this procedure.

1. Obtain permission to disrupt customer operations. Place ONLINE/OFFLINE switch to OFFLINE.
2. Place START/STOP switch in the STOP position.
3. Open the drive front cover.
4. Remove the Electronics Library cover by loosening (DO NOT REMOVE) the two screws in the keyhole slots. Lift the library cover up and away from the drive.
5. Set the MASSBUS ENABLE/DISABLE switch to DISABLE (down).
6. Set the SERVICE switch (S1) OFF (down).
7. At the rear of the drive, raise the top cover and open the drive rear cover.
8. Set CB3, CB2 and CB1 OFF (down) in that order.
9. At the front of the drive remove the Shield Cover Assembly by inserting a narrow pointed object (narrow blade screwdriver) into the hole in the upper center of the shield. By applying pressure the retainer clip will release. Pull down the shield and slide it out.
10. Unbuckle the old Absolute Filter retaining straps. Do not remove the filter at this time.

### **NOTE**

Insure floor in front of the drive is clean. If necessary, place filter on the plastic bag before placing filter on floor (step 11).

11. Remove the replacement filter from its protective plastic bag. (DO NOT remove sealing caps.) Place the replacement filter on floor in front of the drive.
12. Remove cap from the innermost tap of replacement filter.
13. Immediately remove (clear plastic) air pressure hose tubing from the old filter and install onto replacement filter.

14. Loosen (do not remove) the air hose clamp that secures the HDA air hose to the Absolute Filter discharge opening.

**CAUTION**

The HDA air hose must be capped with a plastic bag (clean suitable material may be used) to prevent environmental contaminants from entering it.

15. Remove HDA air hose from the old Absolute Filter and immediately cap hose with plastic bag.
16. Remove old filter from the Blower Assembly. Discard it.
17. Remove protective seal from the intake opening of replacement filter.
18. Place replacement filter into its housing in the Blower Assembly.
19. Remove protective seal from the discharge opening of replacement filter.
20. Immediately remove plastic bag from HDA air hose and install hose onto filter discharge opening.
21. Slide the air hose clamp down around the HDA air hose and the discharge port on the filter. Tighten the clamp.

**NOTE**

Be sure the replacement filter intake opening is aligned with the Blower Assembly outlet before proceeding.

22. Buckle the Absolute Filter retaining straps. Pull retaining straps until the Absolute filter is securely seated against blower housing.
23. Reposition air hose (if necessary) to keep hose from chaffing against any solid object (baseplate or frame).

**NOTE**

Whenever an Absolute Filter has been replaced, an air pressure check is recommended to insure filter performance. See Absolute Filter Air Pressure Check, subsection 5.4.6.1 of this manual.

24. Replace the shield cover assembly.
25. At the rear of the drive set CB1, CB2 and CB3 ON in that order. Close the drive rear door and top cover.

26. Set the SERVICE switch (S1) ON (up).
27. Set the MASSBUS ENABLE/DISABLE switch to ENABLE (up).
28. Replace the Electronics Library cover by sliding the keyhole slots over the two screws. Tighten the two screws.
29. Close the drive front cover.
30. Place START/STOP switch in the START position.
31. Place ONLINE/OFFLINE switch to ONLINE.
32. Perform Power On Start procedure.
33. Resume customer operations.

**5.4.6.3 Airflow Check** - To insure that the air circulation and filtering system of the RP07 drive is functional, perform the following:

1. When AC power is applied to the drive (CB1 ON) the drive blower activates. Check for an audible sound from the blower motor.
2. Visually check both air hoses (HDA air hose and clear plastic air hose) for condition and seating. If an air leak is detected and replacement is required, see Removal and Replacement Procedures, Chapter 4 of this manual. Verify that the air hose clamps are secure. Tighten if necessary.

**5.4.7 Battery Pack Check** - This applies only to drives with a **non-tilted** baseplate.

1. Obtain permission to disrupt customer operations. Set ONLINE/OFFLINE switch to OFFLINE.
2. Place START/STOP switch to STOP. Wait for stack to stop spinning.
3. Set MASSBUS ENABLE/DISABLE switch to DISABLE.
4. Set service switch to OFF.
5. Turn CB1 and CB2 to OFF.
6. Turn CB1 to ON. Turn service switch to ON.
7. Run Routine 3E (pack spin up). When pack comes to speed, install shipping rod.
8. Run Routine 3F (pack spin down). Turn service switch to OFF.
9. Turn CB1 to OFF.

10. IMMEDIATELY check for a voltage reading of 0.2 - 0.3 volts across E1 and E2 connections on battery pack.
11. If there is no voltage, replace the battery. The recommended replacement period is 2-1/2 years.

## APPENDIX A

### BINARY-OCTAL-HEXADECIMAL-DECIMAL CONVERSION

<u>BINARY</u>	<u>OCTAL</u>	<u>HEXADECIMAL</u>	<u>DECIMAL</u>
0 000 000 000	0000	000	0
0 000 000 001	0001	001	1
0 000 000 010	0002	002	2
0 000 000 011	0003	003	3
0 000 000 100	0004	004	4
0 000 000 101	0005	005	5
0 000 000 110	0006	006	6
0 000 000 111	0007	007	7
0 000 001 000	0010	008	8
0 000 001 001	0011	009	9
0 000 001 010	0012	00A	10
0 000 001 011	0013	00B	11
0 000 001 100	0014	00C	12
0 000 001 101	0015	00D	13
0 000 001 110	0016	00E	14
0 000 001 111	0017	00F	15
0 000 010 000	0020	010	16
0 000 010 001	0021	011	17
0 000 010 010	0022	012	18
0 000 010 011	0023	013	19
0 000 010 100	0024	014	20
0 000 010 101	0025	015	21
0 000 010 110	0026	016	22
0 000 010 111	0027	017	23
0 000 011 000	0030	018	24
0 000 011 001	0031	019	25
0 000 011 010	0032	01A	26
0 000 011 011	0033	01B	27
0 000 011 100	0034	01C	28
0 000 011 101	0035	01D	29
0 000 011 110	0036	01E	30
0 000 011 111	0037	01F	31
0 000 100 000	0040	020	32
0 000 100 001	0041	021	33
0 000 100 010	0042	022	34
0 000 100 011	0043	023	35
0 000 100 100	0044	024	36
0 000 100 101	0045	025	37
0 000 100 110	0046	026	38
0 000 100 111	0047	027	39

APPENDIX A (Continued)

BINARY-OCTAL-HEXADECIMAL-DECIMAL CONVERSION

<u>BINARY</u>	<u>OCTAL</u>	<u>HEXADECIMAL</u>	<u>DECIMAL</u>
0 000 101 000	0050	028	40
0 000 101 001	0051	029	41
0 000 101 010	0052	02A	42
0 000 101 011	0053	02B	43
0 000 101 100	0054	02C	44
0 000 101 101	0055	02D	45
0 000 101 110	0056	02E	46
0 000 101 111	0057	02F	47
0 000 110 000	0060	030	48
0 000 110 001	0061	031	49
0 000 110 010	0062	032	50
0 000 110 011	0063	033	51
0 000 110 100	0064	034	52
0 000 110 101	0065	035	53
0 000 110 110	0066	036	54
0 000 110 111	0067	037	55
0 000 111 000	0070	038	56
0 000 111 001	0071	039	57
0 000 111 010	0072	03A	58
0 000 111 011	0073	03B	59
0 000 111 100	0074	03C	60
0 000 111 101	0075	03D	61
0 000 111 110	0076	03E	62
0 000 111 111	0077	03F	63
0 001 000 000	0100	040	64
0 001 000 001	0101	041	65
0 001 000 010	0102	042	66
0 001 000 011	0103	043	67
0 001 000 100	0104	044	68
0 001 000 101	0105	045	69
0 001 000 110	0106	046	70
0 001 000 111	0107	047	71
0 001 001 000	0110	048	72
0 001 001 001	0111	049	73
0 001 001 010	0112	04A	74
0 001 001 011	0113	04B	75
0 001 001 100	0114	04C	76
0 001 001 101	0115	04D	77
0 001 001 110	0116	04E	78
0 001 001 111	0117	04F	79

APPENDIX A (Continued)

BINARY-OCTAL-HEXADECIMAL-DECIMAL CONVERSION

<u>BINARY</u>	<u>OCTAL</u>	<u>HEXADECIMAL</u>	<u>DECIMAL</u>
0 001 010 000	0120	050	80
0 001 010 001	0121	051	81
0 001 010 010	0122	052	82
0 001 010 011	0123	053	83
0 001 010 100	0124	054	84
0 001 010 101	0125	055	85
0 001 010 110	0126	056	86
0 001 010 111	0127	057	87
0 001 011 000	0130	058	88
0 001 011 001	0131	059	89
0 001 011 010	0132	05A	90
0 001 011 011	0133	05B	91
0 001 011 100	0134	05C	92
0 001 011 101	0135	05D	93
0 001 011 110	0136	05E	94
0 001 011 111	0137	05F	95
0 001 100 000	0140	060	96
0 001 100 001	0141	061	97
0 001 100 010	0142	062	98
0 001 100 011	0143	063	99
0 001 100 100	0144	064	100
0 001 100 101	0145	065	101
0 001 100 110	0146	066	102
0 001 100 111	0147	067	103
0 001 101 000	0150	068	104
0 001 101 001	0151	069	105
0 001 101 010	0152	06A	106
0 001 101 011	0153	06B	107
0 001 101 100	0154	06C	108
0 001 101 101	0155	06D	109
0 001 101 110	0156	06E	110
0 001 101 111	0157	06F	111
0 001 110 000	0160	070	112
0 001 110 001	0161	071	113
0 001 110 010	0162	072	114
0 001 110 011	0163	073	115
0 001 110 100	0164	074	116
0 001 110 101	0165	075	117
0 001 110 110	0166	076	118
0 001 110 111	0167	077	119



**APPENDIX A (Continued)**

**BINARY-OCTAL-HEXADECIMAL-DECIMAL CONVERSION**

<u>BINARY</u>	<u>OCTAL</u>	<u>HEXADECIMAL</u>	<u>DECIMAL</u>
0 001 111 000	0170	078	120
0 001 111 001	0171	079	121
0 001 111 010	0172	07A	122
0 001 111 011	0173	07B	123
0 001 111 100	0174	07C	124
0 001 111 101	0175	07D	125
0 001 111 110	0176	07E	126
0 001 111 111	0177	07F	127
0 010 000 000	0200	080	128
0 010 000 001	0201	081	129
0 010 000 010	0202	082	130
0 010 000 011	0203	083	131
0 010 000 100	0204	084	132
0 010 000 101	0205	085	133
0 010 000 110	0206	086	134
0 010 000 111	0207	087	135
0 010 001 000	0210	088	136
0 010 001 001	0211	089	137
0 010 001 010	0212	08A	138
0 010 001 011	0213	08B	139
0 010 001 100	0214	08C	140
0 010 001 101	0215	08D	141
0 010 001 110	0216	08E	142
0 010 001 111	0217	08F	143
0 010 010 000	0220	090	144
0 010 010 001	0221	091	145
0 010 010 010	0222	092	146
0 010 010 011	0223	093	147
0 010 010 100	0224	094	148
0 010 010 101	0225	095	149
0 010 010 110	0226	096	150
0 010 010 111	0227	097	151
0 010 011 000	0230	098	152
0 010 011 001	0231	099	153
0 010 011 010	0232	09A	154
0 010 011 011	0233	09B	155
0 010 011 100	0234	09C	156
0 010 011 101	0235	09D	157
0 010 011 110	0236	09E	158
0 010 011 111	0237	09F	159

APPENDIX A (Continued)

**BINARY-OCTAL-HEXADECIMAL-DECIMAL CONVERSION**

<u>BINARY</u>	<u>OCTAL</u>	<u>HEXADECIMAL</u>	<u>DECIMAL</u>
0 010 100 000	0240	0A0	160
0 010 100 001	0241	0A1	161
0 010 100 010	0242	0A2	162
0 010 100 011	0243	0A3	163
0 010 100 100	0244	0A4	164
0 010 100 101	0245	0A5	165
0 010 100 110	0246	0A6	166
0 010 100 111	0247	0A7	167
0 010 101 000	0250	0A8	168
0 010 101 001	0251	0A9	169
0 010 101 010	0252	0AA	170
0 010 101 011	0253	0AB	171
0 010 101 100	0254	0AC	172
0 010 101 101	0255	0AD	173
0 010 101 110	0256	0AE	174
0 010 101 111	0257	0AF	175
0 010 110 000	0260	0B0	176
0 010 110 001	0261	0B1	177
0 010 110 010	0262	0B2	178
0 010 110 011	0263	0B3	179
0 010 110 100	0264	0B4	180
0 010 110 101	0265	0B5	181
0 010 110 110	0266	0B6	182
0 010 110 111	0267	0B7	183
0 010 111 000	0270	0B8	184
0 010 111 001	0271	0B9	185
0 010 111 010	0272	0BA	186
0 010 111 011	0273	0BB	187
0 010 111 100	0274	0BC	188
0 010 111 101	0275	0BD	189
0 010 111 110	0276	0BE	190
0 010 111 111	0277	0BF	191
0 011 000 000	0300	0C0	192
0 011 000 001	0301	0C1	193
0 011 000 010	0302	0C2	194
0 011 000 011	0303	0C3	195
0 011 000 100	0304	0C4	196
0 011 000 101	0305	0C5	197
0 011 000 110	0306	0C6	198
0 011 000 111	0307	0C7	199

APPENDIX A (Continued)

BINARY-OCTAL-HEXADECIMAL-DECIMAL CONVERSION

<u>BINARY</u>	<u>OCTAL</u>	<u>HEXADECIMAL</u>	<u>DECIMAL</u>
0 011 001 000	0310	0C8	200
0 011 001 001	0311	0C9	201
0 011 001 010	0312	0CA	202
0 011 001 011	0313	0CB	203
0 011 001 100	0314	0CC	204
0 011 001 101	0315	0CD	205
0 011 001 110	0316	0CE	206
0 011 001 111	0317	0CF	207
0 011 010 000	0320	0D0	208
0 011 010 001	0321	0D1	209
0 011 010 010	0322	0D2	210
0 011 010 011	0323	0D3	211
0 011 010 100	0324	0D4	212
0 011 010 101	0325	0D5	213
0 011 010 110	0326	0D6	214
0 011 010 111	0327	0D7	215
0 011 011 000	0330	0D8	216
0 011 011 001	0331	0D9	217
0 011 011 010	0332	0DA	218
0 011 011 011	0333	0DB	219
0 011 011 100	0334	0DC	220
0 011 011 101	0335	0DD	221
0 011 011 110	0336	0DE	222
0 011 011 111	0337	0DF	223
0 011 100 000	0340	0E0	224
0 011 100 001	0341	0E1	225
0 011 100 010	0342	0E2	226
0 011 100 011	0343	0E3	227
0 011 100 100	0344	0E4	228
0 011 100 101	0345	0E5	229
0 011 100 110	0346	0E6	230
0 011 100 111	0347	0E7	231
0 011 101 000	0350	0E8	232
0 011 101 001	0351	0E9	233
0 011 101 010	0352	0EA	234
0 011 101 011	0353	0EB	235
0 011 101 100	0354	0EC	236
0 011 101 101	0355	0ED	237
0 011 101 110	0356	0EE	238
0 011 101 111	0357	0EF	239

APPENDIX A (Continued)

BINARY-OCTAL-HEXADECIMAL-DECIMAL CONVERSION

<u>BINARY</u>	<u>OCTAL</u>	<u>HEXADECIMAL</u>	<u>DECIMAL</u>
0 011 110 000	0360	0F0	240
0 011 110 001	0361	0F1	241
0 011 110 010	0362	0F2	242
0 011 110 011	0363	0F3	243
0 011 110 100	0364	0F4	244
0 011 110 101	0365	0F5	245
0 011 110 110	0366	0F6	246
0 011 110 111	0367	0F7	247
0 011 111 000	0370	0F8	248
0 011 111 001	0371	0F9	249
0 011 111 010	0372	0FA	250
0 011 111 011	0373	0FB	251
0 011 111 100	0374	0FC	252
0 011 111 101	0375	0FD	253
0 011 111 110	0376	0FE	254
0 011 111 111	0377	0FF	255
0 100 000 000	0400	100	256
0 100 000 001	0401	101	257
0 100 000 010	0402	102	258
0 100 000 011	0403	103	259
0 100 000 100	0404	104	260
0 100 000 101	0405	105	261
0 100 000 110	0406	106	262
0 100 000 111	0407	107	263
0 100 001 000	0410	108	264
0 100 001 001	0411	109	265
0 100 001 010	0412	10A	266
0 100 001 011	0413	10B	267
0 100 001 100	0414	10C	268
0 100 001 101	0415	10D	269
0 100 001 110	0416	10E	270
0 100 001 111	0417	10F	271
0 100 010 000	0420	110	272
0 100 010 001	0421	111	273
0 100 010 010	0422	112	274
0 100 010 011	0423	113	275
0 100 010 100	0424	114	276
0 100 010 101	0425	115	277
0 100 010 110	0426	116	278
0 100 010 111	0427	117	279

APPENDIX A (Continued)

**BINARY-OCTAL-HEXADECIMAL-DECIMAL CONVERSION**

<u>BINARY</u>	<u>OCTAL</u>	<u>HEXADECIMAL</u>	<u>DECIMAL</u>
0 100 011 000	0430	118	280
0 100 011 001	0431	119	281
0 100 011 010	0432	11A	282
0 100 011 011	0433	11B	283
0 100 011 100	0434	11C	284
0 100 011 101	0435	11D	285
0 100 011 110	0436	11E	286
0 100 011 111	0437	11F	287
0 100 100 000	0440	120	288
0 100 100 001	0441	121	289
0 100 100 010	0442	122	290
0 100 100 011	0443	123	291
0 100 100 100	0444	124	292
0 100 100 101	0445	125	293
0 100 100 110	0446	126	294
0 100 100 111	0447	127	295
0 100 101 000	0450	128	296
0 100 101 001	0451	129	297
0 100 101 010	0452	12A	298
0 100 101 011	0453	12B	299
0 100 101 100	0454	12C	300
0 100 101 101	0455	12D	301
0 100 101 110	0456	12E	302
0 100 101 111	0457	12F	303
0 100 110 000	0460	130	304
0 100 110 001	0461	131	305
0 100 110 010	0462	132	306
0 100 110 011	0463	133	307
0 100 110 100	0464	134	308
0 100 110 101	0465	135	309
0 100 110 110	0466	136	310
0 100 110 111	0467	137	311
0 100 111 000	0470	138	312
0 100 111 001	0471	139	313
0 100 111 010	0472	13A	314
0 100 111 011	0473	13B	315
0 100 111 100	0474	13C	316
0 100 111 101	0475	13D	317
0 100 111 110	0476	13E	318
0 100 111 111	0477	13F	319

APPENDIX A (Continued)

BINARY-OCTAL-HEXADECIMAL-DECIMAL CONVERSION

<u>BINARY</u>	<u>OCTAL</u>	<u>HEXADECIMAL</u>	<u>DECIMAL</u>
0 101 000 000	0500	140	320
0 101 000 001	0501	141	321
0 101 000 010	0502	142	322
0 101 000 011	0503	143	323
0 101 000 100	0504	144	324
0 101 000 101	0505	145	325
0 101 000 110	0506	146	326
0 101 000 111	0507	147	327
0 101 001 000	0510	148	328
0 101 001 001	0511	149	329
0 101 001 010	0512	14A	330
0 101 001 011	0513	14B	331
0 101 001 100	0514	14C	332
0 101 001 101	0515	14D	333
0 101 001 110	0516	14E	334
0 101 001 111	0517	14F	335
0 101 010 000	0520	150	336
0 101 010 001	0521	151	337
0 101 010 010	0522	152	338
0 101 010 011	0523	153	339
0 101 010 100	0524	154	340
0 101 010 101	0525	155	341
0 101 010 110	0526	156	342
0 101 010 111	0527	157	343
0 101 011 000	0530	158	344
0 101 011 001	0531	159	345
0 101 011 010	0532	15A	346
0 101 011 011	0533	15B	347
0 101 011 100	0534	15C	348
0 101 011 101	0535	15D	349
0 101 011 110	0536	15E	350
0 101 011 111	0537	15F	351
0 101 100 000	0540	160	352
0 101 100 001	0541	161	353
0 101 100 010	0542	162	354
0 101 100 011	0543	163	355
0 101 100 100	0544	164	356
0 101 100 101	0545	165	357
0 101 100 110	0546	166	358
0 101 100 111	0547	167	359

APPENDIX A (Continued)

**BINARY-OCTAL-HEXADECIMAL-DECIMAL CONVERSION**

<u>BINARY</u>	<u>OCTAL</u>	<u>HEXADECIMAL</u>	<u>DECIMAL</u>
0 101 101 000	0550	168	360
0 101 101 001	0551	169	361
0 101 101 010	0552	16A	362
0 101 101 011	0553	16B	363
0 101 101 100	0554	16C	364
0 101 101 101	0555	16D	365
0 101 101 110	0556	16E	366
0 101 101 111	0557	16F	367
0 101 110 000	0560	170	368
0 101 110 001	0561	171	369
0 101 110 010	0562	172	370
0 101 110 011	0563	173	371
0 101 110 100	0564	174	372
0 101 110 101	0565	175	373
0 101 110 110	0566	176	374
0 101 110 111	0567	177	375
0 101 111 000	0570	178	376
0 101 111 001	0571	179	377
0 101 111 010	0572	17A	378
0 101 111 011	0573	17B	379
0 101 111 100	0574	17C	380
0 101 111 101	0575	17D	381
0 101 111 110	0576	17E	382
0 101 111 111	0577	17F	383
0 110 000 000	0600	180	384
0 110 000 001	0601	181	385
0 110 000 010	0602	182	386
0 110 000 011	0603	183	387
0 110 000 100	0604	184	388
0 110 000 101	0605	185	389
0 110 000 110	0606	186	390
0 110 000 111	0607	187	391
0 110 001 000	0610	188	392
0 110 001 001	0611	189	393
0 110 001 010	0612	18A	394
0 110 001 011	0613	18B	395
0 110 001 100	0614	18C	396
0 110 001 101	0615	18D	397
0 110 001 110	0616	18E	398
0 110 001 111	0617	18F	399

APPENDIX A (Continued)

**BINARY-OCTAL-HEXADECIMAL-DECIMAL CONVERSION**

<u>BINARY</u>	<u>OCTAL</u>	<u>HEXADECIMAL</u>	<u>DECIMAL</u>
0 110 010 000	0620	190	400
0 110 010 001	0621	191	401
0 110 010 010	0622	192	402
0 110 010 011	0623	193	403
0 110 010 100	0624	194	404
0 110 010 101	0625	195	405
0 110 010 110	0626	196	406
0 110 010 111	0627	197	407
0 110 011 000	0630	198	408
0 110 011 001	0631	199	409
0 110 011 010	0632	19A	410
0 110 011 011	0633	19B	411
0 110 011 100	0634	19C	412
0 110 011 101	0635	19D	413
0 110 011 110	0636	19E	414
0 110 011 111	0637	19F	415
0 110 100 000	0640	1A0	416
0 110 100 001	0641	1A1	417
0 110 100 010	0642	1A2	418
0 110 100 011	0643	1A3	419
0 110 100 100	0644	1A4	420
0 110 100 101	0645	1A5	421
0 110 100 110	0646	1A6	422
0 110 100 111	0647	1A7	423
0 110 101 000	0650	1A8	424
0 110 101 001	0651	1A9	425
0 110 101 010	0652	1AA	426
0 110 101 011	0653	1AB	427
0 110 101 100	0654	1AC	428
0 110 101 101	0655	1AD	429
0 110 101 110	0658	1AE	430
0 110 101 111	0657	1AF	431
0 110 110 000	0660	1B0	432
0 110 110 001	0661	1B1	433
0 110 110 010	0662	1B2	434
0 110 110 011	0663	1B3	435
0 110 110 100	0664	1B4	436
0 110 110 101	0665	1B5	437
0 110 110 110	0666	1B6	438
0 110 110 111	0667	1B7	439



APPENDIX A (Continued)

BINARY-OCTAL-HEXADECIMAL-DECIMAL CONVERSION

<u>BINARY</u>	<u>OCTAL</u>	<u>HEXADECIMAL</u>	<u>DECIMAL</u>
0 110 111 000	0670	1B8	440
0 110 111 001	0671	1B9	441
0 110 111 010	0672	1BA	442
0 110 111 011	0673	1BB	443
0 110 111 100	0674	1BC	444
0 110 111 101	0675	1BD	445
0 110 111 110	0676	1BE	446
0 110 111 111	0677	1BF	447
0 111 000 000	0700	1C0	448
0 111 000 001	0701	1C1	449
0 111 000 010	0702	1C2	450
0 111 000 011	0703	1C3	451
0 111 000 100	0704	1C4	452
0 111 000 101	0705	1C5	453
0 111 000 110	0706	1C6	454
0 111 000 111	0707	1C7	455
0 111 001 000	0710	1C8	456
0 111 001 001	0711	1C9	457
0 111 001 010	0712	1CA	458
0 111 001 011	0713	1CB	459
0 111 001 100	0714	1CC	460
0 111 001 101	0715	1CD	461
0 111 001 110	0716	1CE	462
0 111 001 111	0717	1CF	463
0 111 010 000	0720	1D0	464
0 111 010 001	0721	1D1	465
0 111 010 010	0722	1D2	466
0 111 010 011	0723	1D3	467
0 111 010 100	0724	1D4	468
0 111 010 101	0725	1D5	469
0 111 010 110	0726	1D6	470
0 111 010 111	0727	1D7	471
0 111 011 000	0730	1D8	472
0 111 011 001	0731	1D9	473
0 111 011 010	0732	1DA	474
0 111 011 011	0733	1DB	475
0 111 011 100	0734	1DC	476
0 111 011 101	0735	1DD	477
0 111 011 110	0736	1DE	478
0 111 011 111	0737	1DF	479

APPENDIX A (Continued)

BINARY-OCTAL-HEXADECIMAL-DECIMAL CONVERSION

<u>BINARY</u>	<u>OCTAL</u>	<u>HEXADECIMAL</u>	<u>DECIMAL</u>
0 111 100 000	0740	1E0	480
0 111 100 001	0741	1E1	481
0 111 100 010	0742	1E2	482
0 111 100 011	0743	1E3	483
0 111 100 100	0744	1E4	484
0 111 100 101	0745	1E5	485
0 111 100 110	0746	1E6	486
0 111 100 111	0747	1E7	487
0 111 101 000	0750	1E8	488
0 111 101 001	0751	1E9	489
0 111 101 010	0752	1EA	490
0 111 101 011	0753	1EB	491
0 111 101 100	0754	1EC	492
0 111 101 101	0755	1ED	493
0 111 101 110	0756	1EE	494
0 111 101 111	0757	1EF	495
0 111 110 000	0760	1F0	496
0 111 110 001	0761	1F1	497
0 111 110 010	0762	1F2	498
0 111 110 011	0763	1F3	499
0 111 110 100	0764	1F4	500
0 111 110 101	0765	1F5	501
0 111 110 110	0766	1F6	502
0 111 110 111	0767	1F7	503
0 111 111 000	0770	1F8	504
0 111 111 001	0771	1F9	505
0 111 111 010	0772	1FA	506
0 111 111 011	0773	1FB	507
0 111 111 100	0774	1FC	508
0 111 111 101	0775	1FD	509
0 111 111 110	0776	1FE	510
0 111 111 111	0777	1FF	511
1 000 000 000	1000	200	512
1 000 000 001	1001	201	513
1 000 000 010	1002	202	514
1 000 000 011	1003	203	515
1 000 000 100	1004	204	516
1 000 000 101	1005	205	517
1 000 000 110	1006	206	518
1 000 000 111	1007	207	519

APPENDIX A (Continued)

**BINARY-OCTAL-HEXADECIMAL-DECIMAL CONVERSION**

<u>BINARY</u>	<u>OCTAL</u>	<u>HEXADECIMAL</u>	<u>DECIMAL</u>
1 000 001 000	1010	208	520
1 000 001 001	1011	209	521
1 000 001 010	1012	20A	522
1 000 001 011	1013	20B	523
1 000 001 100	1014	20C	524
1 000 001 101	1015	20D	525
1 000 001 110	1016	20E	526
1 000 001 111	1017	20F	527
1 000 010 000	1020	210	528
1 000 010 001	1021	211	529
1 000 010 010	1022	212	530
1 000 010 011	1023	213	531
1 000 010 100	1024	214	532
1 000 010 101	1025	215	533
1 000 010 110	1026	216	534
1 000 010 111	1027	217	535
1 000 011 000	1030	218	536
1 000 011 001	1031	219	537
1 000 011 010	1032	21A	538
1 000 011 011	1033	21B	539
1 000 011 100	1034	21C	540
1 000 011 101	1035	21D	541
1 000 011 110	1036	21E	542
1 000 011 111	1037	21F	543
1 000 100 000	1040	220	544
1 000 100 001	1041	221	545
1 000 100 010	1042	222	546
1 000 100 011	1043	223	547
1 000 100 100	1044	224	548
1 000 100 101	1045	225	549
1 000 100 110	1046	226	550
1 000 100 111	1047	227	551
1 000 101 000	1050	228	552
1 000 101 001	1051	229	553
1 000 101 010	1052	22A	554
1 000 101 011	1053	22B	555
1 000 101 100	1054	22C	556
1 000 101 101	1055	22D	557
1 000 101 110	1056	22E	558
1 000 101 111	1057	22F	559

APPENDIX A (Continued)

**BINARY-OCTAL-HEXADECIMAL-DECIMAL CONVERSION**

<u>BINARY</u>	<u>OCTAL</u>	<u>HEXADECIMAL</u>	<u>DECIMAL</u>
1 000 110 000	1060	230	560
1 000 110 001	1061	231	561
1 000 110 010	1062	232	562
1 000 110 011	1063	233	563
1 000 110 100	1064	234	564
1 000 110 101	1065	235	565
1 000 110 110	1066	236	566
1 000 110 111	1067	237	567
1 000 111 000	1070	238	568
1 000 111 001	1071	239	569
1 000 111 010	1072	23A	570
1 000 111 011	1073	23B	571
1 000 111 100	1074	23C	572
1 000 111 101	1075	23D	573
1 000 111 110	1076	23E	574
1 000 111 111	1077	23F	575
1 001 000 000	1100	240	576
1 001 000 001	1101	241	577
1 001 000 010	1102	242	578
1 001 000 011	1103	243	579
1 001 000 100	1104	244	580
1 001 000 101	1105	245	581
1 001 000 110	1106	246	582
1 001 000 111	1107	247	583
1 001 001 000	1110	248	584
1 001 001 001	1111	249	585
1 001 001 010	1112	24A	586
1 001 001 011	1113	24B	587
1 001 001 100	1114	24C	588
1 001 001 101	1115	24D	589
1 001 001 110	1116	24E	590
1 001 001 111	1117	24F	591
1 001 010 000	1120	250	592
1 001 010 001	1121	251	593
1 001 010 010	1122	252	594
1 001 010 011	1123	253	595
1 001 010 100	1124	254	596
1 001 010 101	1125	255	597
1 001 010 110	1126	256	598
1 001 010 111	1127	257	599

APPENDIX A (Continued)

BINARY-OCTAL-HEXADECIMAL-DECIMAL CONVERSION

<u>BINARY</u>	<u>OCTAL</u>	<u>HEXADECIMAL</u>	<u>DECIMAL</u>
1 001 011 000	1130	258	600
1 001 011 001	1131	259	601
1 001 011 010	1132	25A	602
1 001 011 011	1133	25B	603
1 001 011 100	1134	25C	604
1 001 011 101	1135	25D	605
1 001 011 110	1136	25E	606
1 001 011 111	1137	25F	607
1 001 100 000	1140	260	608
1 001 100 001	1141	261	609
1 001 100 010	1142	262	610
1 001 100 011	1143	263	611
1 001 100 100	1144	264	612
1 001 100 101	1145	265	613
1 001 100 110	1146	266	614
1 001 100 111	1147	267	615
1 001 101 000	1150	268	616
1 001 101 001	1151	269	617
1 001 101 010	1152	26A	618
1 001 101 011	1153	26B	619
1 001 101 100	1154	26C	620
1 001 101 101	1155	26D	621
1 001 101 110	1156	26E	622
1 001 101 111	1157	26F	623
1 001 110 000	1160	270	624
1 001 110 001	1161	271	625
1 001 110 010	1162	272	626
1 001 110 011	1163	273	627
1 001 110 100	1164	274	628
1 001 110 101	1165	275	629
1 001 110 110	1166	276	630
1 001 110 111	1167	277	631

**APPENDIX B**  
**HDA CROSS CONNECT PROCEDURE**

**NOTE**

Troubleshooting tool - not for customer data backup or recovery.

This procedure is to be used to check out an HDA Assembly on one RP07 by using the electronics of a second RP07 without removing the HDA. The two RP07 drives must be adjacent to each other because of the length restrictions of the cables used. An HDA cable kit (29-23609-00) is needed.

1. Get authorization from the customer to take both drives offline.
2. Place the ONLINE/OFFLINE switch in the OFFLINE position (down) on both drives.
3. Place the START/STOP switch in the STOP position (down) on both drives.
4. Place the Service Switch on the A1A3 PCA in the OFF (down) position on both drives. Also place CBI in the OFF (down) position on both drives.
5. Disconnect the stack motor cable from J4 on the AC Power Distribution Assembly on both drives.
6. Find the motor jumper cable (ISS P/N 9046090) in the HDA test cable kit. Connect the cable from J4 of the good drive to the motor cable of the problem drive.
7. Disconnect the EMA leads (black and white twisted pair) from E1 and E2 on the backplane of the good drive. E1 and E2 are found near pins 159 and 160 of J2.

**CAUTION**

Failure to completely disconnect EMA leads from backpanel of the good drive will result in damage to good HDA.

8. Disconnect the EMA leads at the HDA of the problem drive.
9. Find the EMA jumper cable (ISS P/N 9046091) in the HDA test cable kit. Connect the cable from E1 and E2 on the backplane of the good drive to the HDA of the problem drive. Tighten ground leads at both ends.
10. Disconnect the HDA flexprint cable on both drives. This cable is connected at pins 121170 on J17 of the backpanel.
11. Find the HDA flat jumper cable (ISS P/N 9046089) in the HDA test cable kit. Connect the male end of the cable to the HDA in the problem drive, and the female end of the cable to A1J17 of the good drive. Tighten grounds at both ends.
12. Place CB1 in the ON (up) position on the problem drive. (Leave the Service Switch in the OFF (down) position.

#### **CAUTION**

The blowers must be running on both drives to provide air and prevent damage to the HDAs.

13. Make sure that the FE LOCAL/NORMAL switch is in the NORMAL position on the good drive.
14. Place CB1 in the ON (up) position and the Service Switch on the A1A3 PCA in the on (up) position on the good drive.
15. Place the START/STOP switch in the START position (up) on the good drive. Wait approximately 90 seconds for the drive and the HDA to cycle up.
16. The drive and the HDA will be checked out by the drive diagnostics during the power up sequence. If an error code is present in the data display, use microdiagnostics to make sure that the problem is in the HDA.

If no error code is present, subsystem diagnostics can be run after placing the ONLINE/OFFLINE switch in the ONLINE position (up).

17. If no problem occurs, it can be assumed that the HDA in the problem drive is good. If a problem still occurs, it can be assumed that the HDA in the problem drive is bad.

The following steps should be used to return the two drives to their usual status. Step 23 may be omitted if you are going to replace the HDA on the problem drive.

18. Make sure that the ONLINE/OFFLINE switch is in the OFFLINE position (down) on both drives.
19. Place the START/STOP switch in the STOP position (down) on the good drive.

20. Place the Service Switch in the OFF (down) position on the good drive.
21. Place CBI in the OFF (down) position on both drives.
22. Remove the three jumper cables of the HDA test cable kit from the drives.
23. Reconnect the EMA leads to the HDA on the problem drive.
24. Reconnect the EMA leads to E1 and E2 on the backplane of the good drive.
25. Reconnect the stack motor cable to J4 on the AC Power Distribution Box of the good drive.
26. Reconnect the stack motor cable to A2J4 on the AC Power Distribution Box of the problem drive.
27. Reconnect the HDA flexprint cable to J17 on the backplane of both drives. Make sure that all grounds are correctly connected.

Both drives are now back to their normal configuration. They may be powered up or worked on as required.